

Intelligent dynamic XZS



It Is A Manufacture Intergrating R&D,Production Processing,Distribution And After-Sales

AGV RGV Intelligent Dynamic Gear

XZS

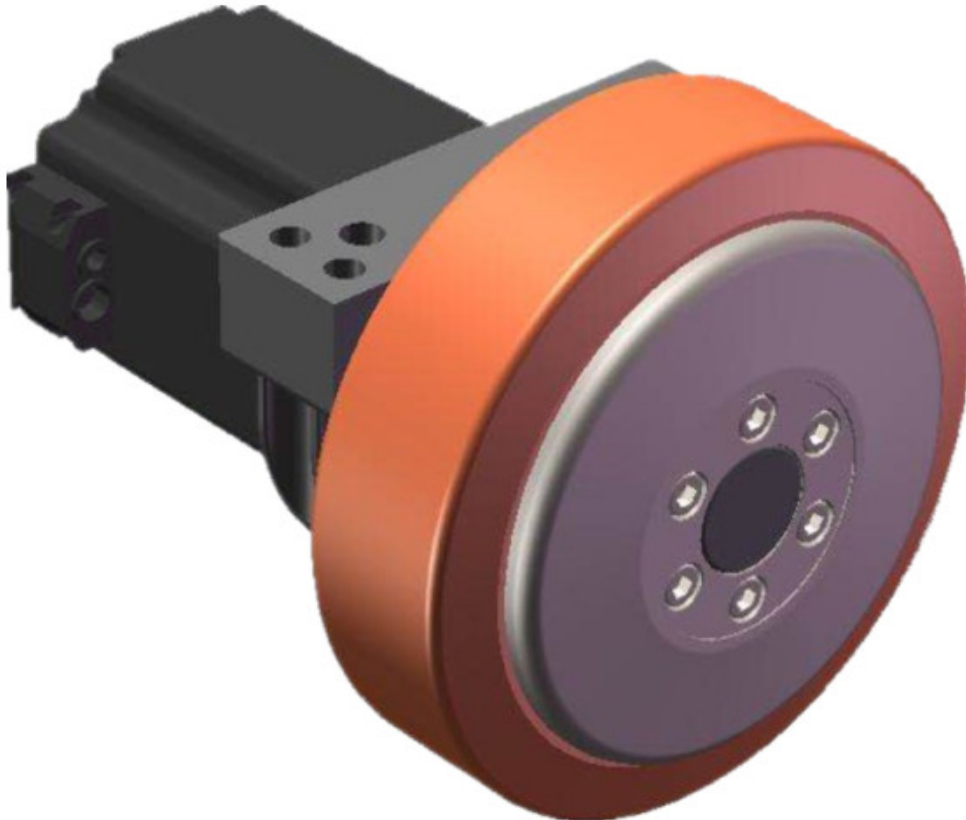

WIDE RANGE
of Products

STRONG
Economic Foundation

COMPLETE
Technology & Staffing

XZS Series Reducer Characteristics:

- 1,Helical gear transmission ,carburizing and quenching treatment, tooth profile modification treatment ,to ensure low noise and smooth operation .The bearing capacity is 20% higher than that of straight teeth.
- 2,Integral output shaft and bearing support at both ends of planetary wheel to achieve high precision and strength.
- 3,The backlash clearance is small ,and the precision single stage can achieve less than 3 arc min.

Intelligent dynamic XZS

Product features

Precision planetary gear reducer is a new generation of practical products independently developed by our company, which has the following main characteristics.

1,Low noise

below 65db

2,High input speed

Up to 5000RPM

3,Low Backlash

One stage within 3 arc minutes, two stage with 5 arc/min

4,High torque

Higher than conventional planetary gearbox

5,High efficiency

One Stage is exceed97%,Two stage is exceed 95%

6,High stability

Using high-strength steel alloy material .Not just hardening on gear surface, but hardening entire gear to insure the gear life time and maintain high accuracy.

Product Application

Precision planetary gear reducer is widely used in the following fields

01 , Aerospace ,military industries

02, Medical health care, electronic information technology industry.

03,Industrial robot, production automation ,CNC machine tool manufacturing industry

04, Motor, textile, printing, food, metallurgical, environmental protection engineering, warehouse and logistics industry.

Intelligent dynamic XZS

| Traction motor parameters | | Motor Power | Motor Voltage | Motor speed | Motor current | Rated torque | IP Grade | Encoder | |
|---------------------------|-------------|-------------|---------------|-------------|---------------|--------------|----------|-------------------|------------------|
| Type | DC | W | V | RPM | A | Nm | IP | Magnetic braiding | Resolution ratio |
| | Servo Motor | 200 | 48 | 3000 | 5.1 | 0.64 | 65 | Increment | 1024 |

| Traction reducer parameters | Type | X | Planetary reducer | | | | | | |
|-----------------------------|---------------------|-----------|-------------------|-------|-------|------|------|------|------|
| | Reducer speed ratio | i | 10 | 12 | 16 | 20 | 35 | 50 | 70 |
| | Reducer torque | Nm | 40 | 90 | 100 | 105 | 110 | 110 | 70 |
| | Polyurethane Loaded | Kg | 400 | | | | | | |
| | Rubber Loaded | Kg | 350 | | | | | | |
| | Maximum speed | M/min | 150.7 | 125.6 | 94.2 | 75.4 | 43.1 | 30.1 | 21.5 |
| | Traction | N | 80 | 96 | 128 | 160 | 280 | 400 | 560 |
| | Traction weight | reference | 152 | 182.4 | 243.2 | 304 | 532 | 706 | 1064 |

| Another | Reducer lubrication | lubricant | (-20°~200°) |
|---------|---------------------|-----------|-------------|
| | Dead-weight | Kg | About4.8 |

ZL-XZS-200-48-45-180-10(70)

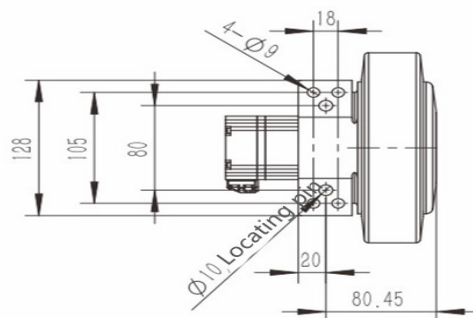
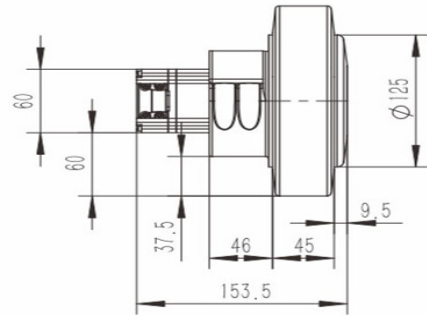
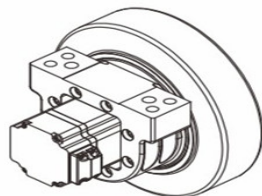
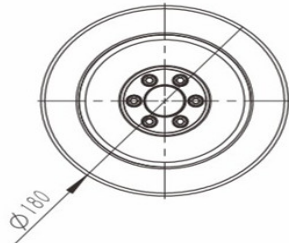

ZL-XZS-200-48-45-180-10(70)

Intelligent dynamic XZS

| Traction motor parameters | | Motor Power | Motor Voltage | Motor speed | Motor current | Rated torque | IP Grade | Encoder | |
|---------------------------|-------------|-------------|---------------|-------------|---------------|--------------|----------|-------------------|------------------|
| Type | DC | W | V | RPM | A | Nm | IP | Magnetic braiding | Resolution ratio |
| | Servo Motor | 200 | 48 | 3000 | 5.1 | 0.64 | 65 | Increment | 1024 |

| Traction reducer parameters | Type | X | Planetary reducer | | | | | | |
|-----------------------------|---------------------|-----------|-------------------|-------|-------|-------|-------|-------|-------|
| | Reducer speed ratio | i | 10 | 12 | 16 | 20 | 35 | 50 | 70 |
| | Reducer torque | Nm | 40 | 90 | 100 | 105 | 110 | 110 | 70 |
| | Polyurethane Loaded | Kg | 400 | | | | | | |
| | Rubber Loaded | Kg | 350 | | | | | | |
| | Maximum speed | M/min | 169.6 | 141.3 | 106 | 84.8 | 48.4 | 33.9 | 24.2 |
| | Traction | N | 71 | 85.3 | 113.8 | 142.2 | 248.9 | 355.6 | 497.8 |
| | Traction weight | reference | 135 | 162.1 | 216.2 | 270.2 | 472.9 | 675.6 | 945.8 |

| Another | Reducer lubrication | lubricant | (-20°~200°) |
|---------|---------------------|-----------|-------------|
| | Dead-weight | Kg | About4.8 |

ZL-XZS-400-48-45-160-10(70)

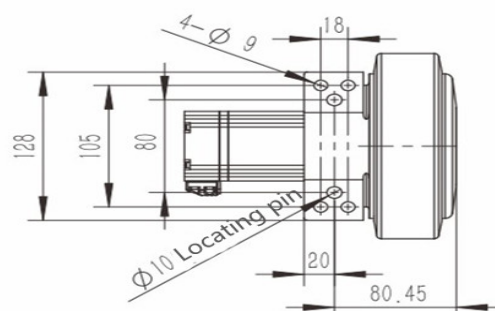
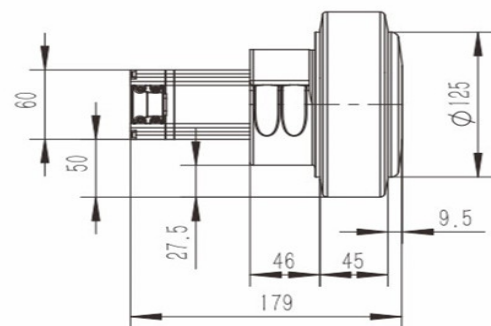
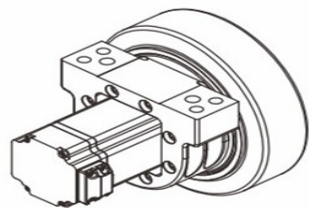
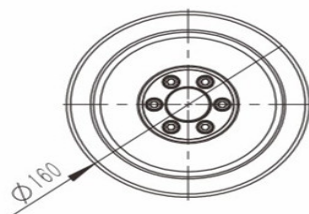

ZL-XZS-400-48-45-160-10(70)

Intelligent dynamic XZS

| Traction motor parameters | | Motor Power | Motor Voltage | Motor speed | Motor current | Rated torque | IP Grade | Encoder | |
|---------------------------|-------------|-------------|---------------|-------------|---------------|--------------|----------|-------------------|------------------|
| Type | DC | W | V | RPM | A | Nm | IP | Magnetic braiding | Resolution ratio |
| | Servo Motor | 400 | 48 | 3000 | 10.1 | 1.27 | 65 | Increment | 1024 |

| | | | | | | | | | |
|-----------------------------|---------------------|-----------|-------------------|-------|-------|-------|--------|--------|--------|
| Traction reducer parameters | Type | X | Planetary reducer | | | | | | |
| | Reducer speed ratio | i | 10 | 12 | 16 | 20 | 35 | 50 | 70 |
| | Reducer torque | Nm | 40 | 90 | 100 | 105 | 110 | 110 | 70 |
| | Polyurethane Loaded | Kg | 400 | | | | | | |
| | Rubber Loaded | Kg | 350 | | | | | | |
| | Maximum speed | M/min | 150.7 | 125.6 | 94.2 | 75.4 | 43.1 | 30.1 | 21.5 |
| | Traction | N | 159 | 190.5 | 254 | 317.5 | 555.6 | 793.8 | 1111.3 |
| | Traction weight | reference | 302 | 362 | 482.6 | 603.3 | 1055.7 | 1508.1 | 2111.4 |

| | | | |
|---------|---------------------|-----------|-------------|
| Another | Reducer lubrication | lubricant | (-20°~200°) |
| | Dead-weight | Kg | About5 |

ZL-XZS-400-48-45-180-10(70)

ZL-XZS-400-48-45-180-10(70)

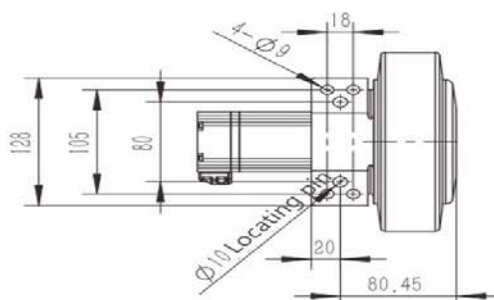
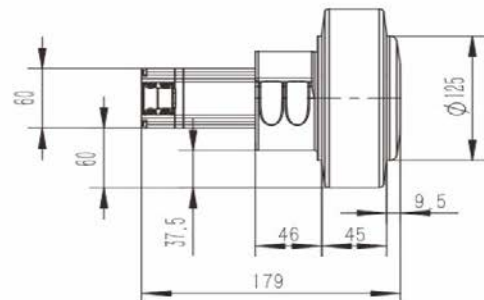
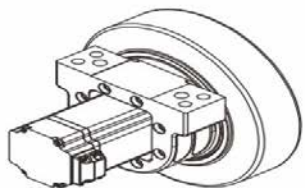
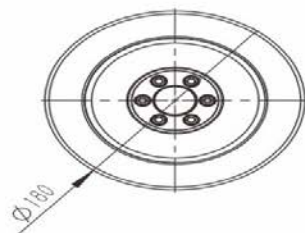

Intelligent dynamic XZS

| Traction motor parameters | | Motor Power | Motor Voltage | Motor speed | Motor current | Rated torque | IP Grade | Encoder | |
|---------------------------|-------------|-------------|---------------|-------------|---------------|--------------|----------|-------------------|------------------|
| Type | DC | W | V | RPM | A | Nm | IP | Magnetic braiding | Resolution ratio |
| | Servo Motor | 400 | 48 | 3000 | 10.1 | 1.27 | 65 | Increment | 1024 |

| | | | | | | | | | |
|-----------------------------|---------------------|-----------|-------------------|-------|-------|-------|-------|--------|--------|
| Traction reducer parameters | Type | X | Planetary reducer | | | | | | |
| | Reducer speed ratio | i | 10 | 12 | 16 | 20 | 35 | 50 | 70 |
| | Reducer torque | Nm | 40 | 90 | 100 | 105 | 110 | 110 | 70 |
| | Polyurethane Loaded | Kg | 400 | | | | | | |
| | Rubber Loaded | Kg | 350 | | | | | | |
| | Maximum speed | M/min | 169.6 | 141.3 | 106 | 84.8 | 48.4 | 33.9 | 24.2 |
| | Traction | N | 141 | 169.3 | 225.8 | 282.2 | 493.9 | 705.6 | 987.8 |
| | Traction weight | reference | 268 | 321.7 | 429 | 536.2 | 938.4 | 1340.6 | 1876.8 |

| | | | |
|---------|---------------------|-----------|-------------|
| Another | Reducer lubrication | lubricant | (-20°~200°) |
| | Dead-weight | Kg | About5 |

ZL-XZS-750-48-45-160-10(70)

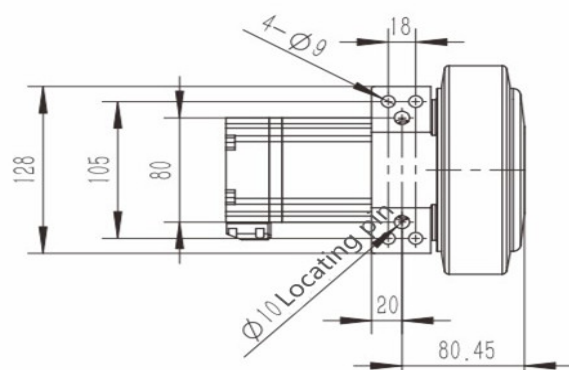
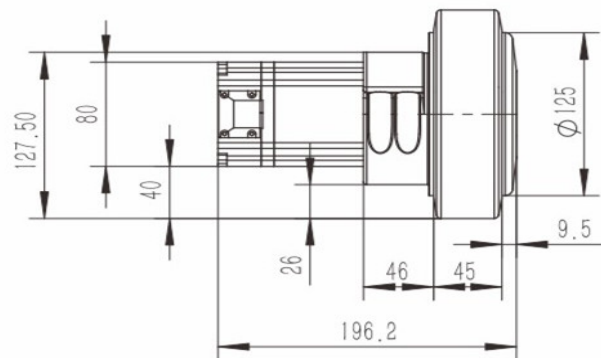
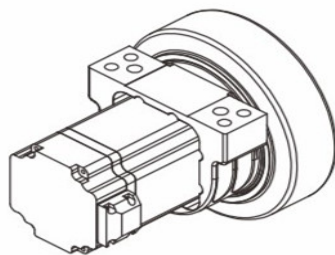
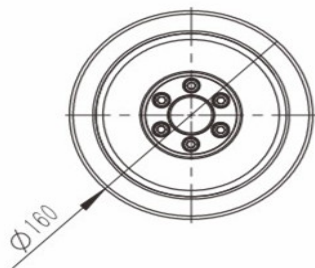

ZL-XZS-750-48-45-160-10(70)

Intelligent dynamic XZS

| Traction motor parameters | | Motor Power | Motor Voltage | Motor speed | Motor current | Rated torque | IP Grade | Encoder | |
|---------------------------|-------------|-------------|---------------|-------------|---------------|--------------|----------|-------------------|------------------|
| Type | DC | W | V | RPM | A | Nm | IP | Magnetic braiding | Resolution ratio |
| | Servo Motor | 750 | 48 | 3000 | 19 | 2.39 | 65 | Increment | 1024 |

| | | | | | | | | | |
|-----------------------------|---------------------|-----------|-------------------|-------|-------|--------|--------|--------|--------|
| Traction reducer parameters | Type | X | Planetary reducer | | | | | | |
| | Reducer speed ratio | i | 10 | 12 | 16 | 20 | 35 | 50 | 70 |
| | Reducer torque | Nm | 40 | 90 | 100 | 105 | 110 | 110 | 70 |
| | Polyurethane Loaded | Kg | 400 | | | | | | |
| | Rubber Loaded | Kg | 350 | | | | | | |
| | Maximum speed | M/min | 150.7 | 125.6 | 94.2 | 75.4 | 43.1 | 30.1 | 21.5 |
| | Traction | N | 284 | 340.6 | 454.1 | 567.6 | 993.3 | 1344.4 | 1568.4 |
| | Traction weight | reference | 539 | 647.1 | 862.8 | 1078.5 | 1887.4 | 2554.3 | 2980 |

| | | | |
|---------|---------------------|-----------|-------------|
| Another | Reducer lubrication | lubricant | (-20°~200°) |
| | Dead-weight | Kg | About5.5 |

ZL-XZS-750-48-45-180-10(70)

ZL-XZS-750-48-45-180-10(70)

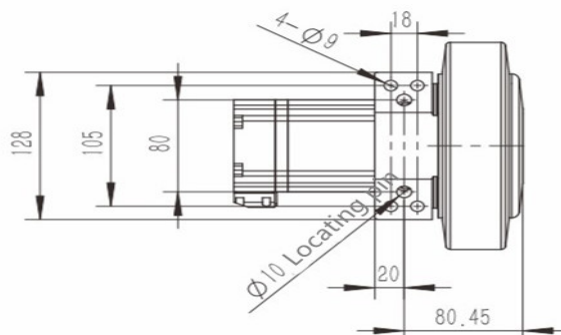
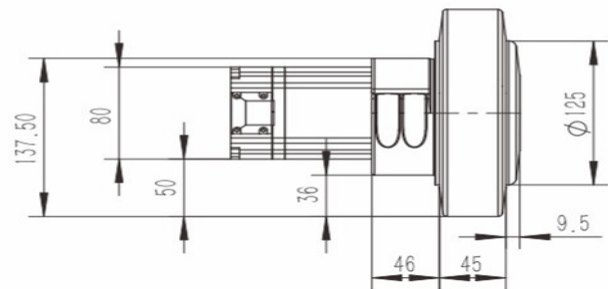
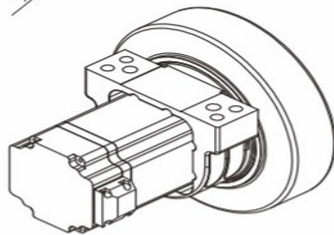
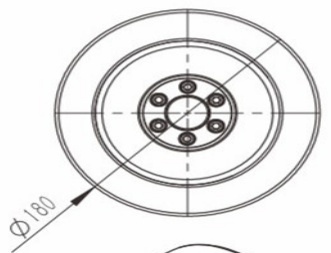

Intelligent dynamic XZS

| Traction motor parameters | | Motor Power | Motor Voltage | Motor speed | Motor current | Rated torque | IP Grade | Encoder | |
|---------------------------|-------------|-------------|---------------|-------------|---------------|--------------|----------|-------------------|------------------|
| Type | DC | W | V | RPM | A | Nm | IP | Magnetic braiding | Resolution ratio |
| | Servo Motor | 750 | 48 | 3000 | 19 | 2.39 | 65 | Increment | 1024 |

| | | | | | | | | | |
|-----------------------------|---------------------|-----------|-------------------|-------|-------|-------|--------|------|--------|
| Traction reducer parameters | Type | X | Planetary reducer | | | | | | |
| | Reducer speed ratio | i | 10 | 12 | 16 | 20 | 35 | 50 | 70 |
| | Reducer torque | Nm | 40 | 90 | 100 | 105 | 110 | 110 | 70 |
| | Polyurethane Loaded | Kg | 400 | | | | | | |
| | Rubber Loaded | Kg | 350 | | | | | | |
| | Maximum speed | M/min | 169.6 | 141.3 | 106 | 84.8 | 48.4 | 33.9 | 24.2 |
| | Traction | N | 252 | 302.7 | 403.6 | 504.6 | 883 | 1195 | 1394.2 |
| | Traction weight | reference | 479 | 575.2 | 766.9 | 958.7 | 1677.6 | 2270 | 2648.9 |

| | | | |
|---------|---------------------|-----------|-------------|
| Another | Reducer lubrication | lubricant | (-20°~200°) |
| | Dead-weight | Kg | About5.5 |

XZS165 Series: ZL-XZS-1500-48-80-220-10(70)

ZL-XZS-1500-48-80-220-10(70)

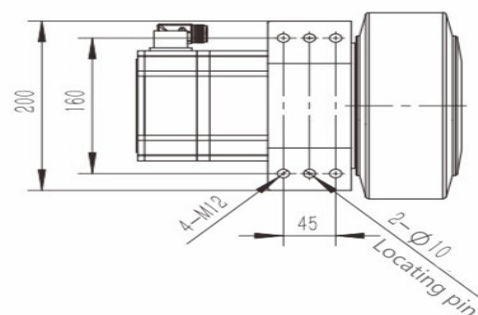
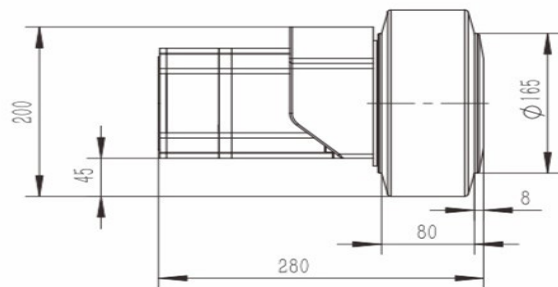
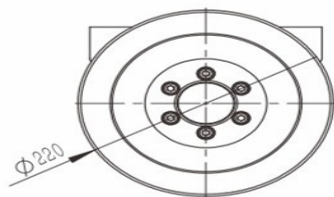
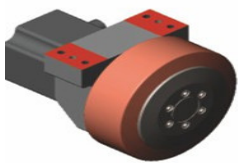

Intelligent dynamic XZS

| Traction motor parameters | | Motor Power | Motor Voltage | Motor speed | Motor current | Rated torque | IP Grade | Encoder | |
|---------------------------|-------------|-------------|---------------|-------------|---------------|--------------|----------|-------------------|------------------|
| Type | DC | W | V | RPM | A | Nm | IP | Magnetic braiding | Resolution ratio |
| | Servo Motor | 1500 | 48 | 3000 | 19 | 2.39 | 65 | Increment | 1024 |

| | | | | | | | | | |
|-----------------------------|---------------------|-----------|-------------------|-------|-------|-------|--------|--------|--------|
| Traction reducer parameters | Type | X | Planetary reducer | | | | | | |
| | Reducer speed ratio | i | 10 | 12 | 16 | 20 | 35 | 50 | 70 |
| | Reducer torque | Nm | 40 | 90 | 100 | 105 | 110 | 110 | 70 |
| | Polyurethane Loaded | Kg | 400 | | | | | | |
| | Rubber Loaded | Kg | 350 | | | | | | |
| | Maximum speed | M/min | 207.2 | 172.7 | 129.5 | 103.6 | 59.2 | 41.4 | 21.5 |
| | Traction | N | 206 | 247.7 | 330.3 | 412.8 | 722.4 | 977.7 | 1140.7 |
| | Traction weight | reference | 392 | 470.6 | 627.5 | 784.4 | 1372.6 | 1857.7 | 2167 |

| | | | |
|---------|---------------------|-----------|-------------|
| Another | Reducer lubrication | lubricant | (-20°~200°) |
| | Dead-weight | Kg | About5 |

ZL-XZS-1500-48-80-250-10(70)

ZL-XZS-1500-48-80-250-10(70)

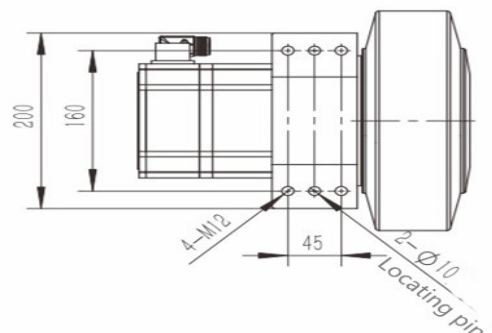
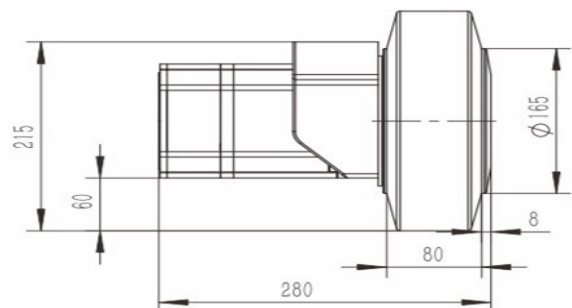
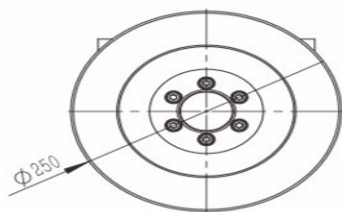
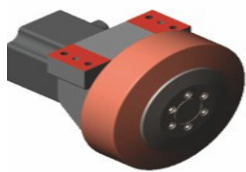

Intelligent dynamic XZS

| Traction motor parameters | | Motor Power | Motor Voltage | Motor speed | Motor current | Rated torque | IP Grade | Encoder | |
|---------------------------|-------------|-------------|---------------|-------------|---------------|--------------|----------|-------------------|------------------|
| Type | DC | W | V | RPM | A | Nm | IP | Magnetic braiding | Resolution ratio |
| | Servo Motor | 1500 | 48 | 3000 | 37.4 | 5 | 65 | Increment | 1024 |

| | | | | | | | | | |
|-----------------------------|---------------------|-----------|-------------------|-------|--------|-------|------|------|------|
| Traction reducer parameters | Type | X | Planetary reducer | | | | | | |
| | Reducer speed ratio | i | 10 | 12 | 16 | 20 | 35 | 50 | 70 |
| | Reducer torque | Nm | 80 | 180 | 200 | 210 | 220 | 220 | 140 |
| | Polyurethane Loaded | Kg | 1500 | | | | | | |
| | Rubber Loaded | Kg | 1380 | | | | | | |
| | Maximum speed | M/min | 235.5 | 196.3 | 147.2 | 117.8 | 67.3 | 47.1 | 21.5 |
| | Traction | N | 380 | 456 | 608 | 460 | 1330 | 1800 | 2100 |
| | Traction weight | reference | 722 | 866.4 | 1155.2 | 1444 | 2527 | 3420 | 3990 |

| | | | |
|---------|---------------------|-----------|-------------|
| Another | Reducer lubrication | lubricant | (-20°~200°) |
| | Dead-weight | Kg | About 11 |

Intelligent dynamic XZS

Delivery time :

| | | |
|------------------|--------|------------------|
| Quantity(Pieces) | 1 - 50 | >50 |
| Est. Time(days) | 45 | To be negotiated |

FAQ

Q:Are you factory?

A:Yes, we are facotry, and we produce stepper motor and gearbox reducer and AGV RGV for more than 15 years in China.

Q: What should I do, if I have no idea about parameter of motor and driver?

A:Please don't worry, send the picture and application to our professional sale, and we will give you the best suggestion.

Q: How long is your products quality warranty?

A: We provide one year factory quality warranty.

Q: How long is your delivery time?

A: When the order is confirmed, 7 working days for the small order,15~20 days for the bulk.

Q:Can you offer me OEM service?

A:Yes,However,you should give me more request as you can.

Q:How to choose suitable model?

A:Please provide a photo of the product you used before or advise us your needs, we will give suggestion .

Q:What's your MOQ?

A:Normally one piece. If more, we can talk about discount. You can mix it with other Shenli machine parts shipping together .

Q: What is your terms of payment ?

A: 100% in advance. Payment \geq 50000USD, 50% T/T in advance, balance before shipment .

Q: How does your QC work?

A: We have performance test ,Sampling test ,routing test and acceptance test.

Q:Why choose your company?

A:We are a professional Industrial Solutions company in China. we're passed IS9001 international quality system certification; the products have respectively passed quality certification of CE, ROHS, FCC etc. Our brand quality can be supply high cost performance transmission control products for the world industrial control.

Intelligent dynamic XZS
