

DSL200-P

SERVO DRIVE INSTRUCTIONS



 **DANGEROUS**

- To use the appropriate force to fasten each wiring terminals in the main circuit.
Otherwise, it is easy to cause spark, even the fire because the wires would be loosed.

- To install all drive units and brake resistors above the non-combustible objects, and keep away from the flammable material.
Otherwise, it is easy to cause the fire.

- To make sure that the input power supply is off before wiring.
Otherwise, the electric shock maybe occurs.

- To install circuit breakers, interference filters and AC reactors in time.
Otherwise, the lightning strikes, failures or damages maybe occur.

- wiring or inspection shall be carried out by the professional electrical engineers.
Otherwise, the electric shock or fire maybe occur.

- If move, wire distribution, inspection or maintenance are to be needed, it shouldn't be carried out until 10 minutes after the power is turned off.
Otherwise, the electric shock maybe occurs.

- PE, the servo unit grounding terminal, must be grounded.
Otherwise, the electric shock maybe occurs.

- To install the emergency-stop switch.
Otherwise, injury, failures or mechanical damages maybe occur.

- To ensure the wiring correct.
Otherwise, it is easy to cause the electric shock.

- To make sure to tighten the power terminals and the motor output terminals.
Otherwise, injury, failures and mechanical damages maybe occur.

- Don't open cover plate of the terminal strip when servo drive is electrified or running.
Otherwise, the electric shock maybe occurs.

- Don't touch the main circuit wiring terminal of the drive unit directly.
Otherwise, the electric shock maybe occurs.

- Don't operate the switch by wet hands.
Otherwise, the electric shock maybe occurs.

- Don't prevent heat diffusion or place the irrelevant objects inside the dissipation fans or radiators.
Otherwise, damages and fires maybe occur.

- Don't operate the spindle motor shaft connecting device right now after the power supply is restored, because it perhaps be started suddenly.

Otherwise, personal injury maybe occurs.

■Don't put your hands inside the servo units.

Otherwise, It is easy to have electric shock.

■Don't put the wires on the sharp edge. Don't carry the heavy load and huge pulling force.

Otherwise, electric shock, failures and damages maybe occur.

■Don't operate the spindle drive device when it is electrified, after removing the cover plate of the terminal strip.

Otherwise, the electric shock maybe occurs.

CAUTIOUS

- To correctly connect drive units and motors strictly depending on the wiring diagram.
Otherwise, it maybe damages the devices.
- The loaded voltage grades on each terminal should base on those that were ruled in the instructions.
Otherwise, it maybe damages the devices.
- Only can Load operating be carried after the no-load running of motor has be tested successfully.
Otherwise, it maybe damages the devices.
- After the alarm occurs, please exclude the alarm before running.
Otherwise, it maybe damages the devices.
- To correctly connect the brake resistances according to the wiring diagram.
Otherwise, it is easy to cause spark, even the fire because the wires would be loosed.
- Motor must match with the appropriate servo units.
Otherwise, it maybe damages the devices.
- Don't modify, detach or maintain the drive units privately.
Otherwise, it maybe damages the devices.
- Don't hold the cable and motor shaft during the transportation.
Otherwise, it maybe damages the devices.
- Don't touch the heat dissipation device of motor, brake resistance or servo units when it is running because the high temperature maybe occurs.
Otherwise, it maybe burns the hands.
- Don't extremely adjust or modify the parameters privately.
Otherwise, it maybe damages the devices.
- Don't connect the input terminals R, S, T of power supply with the output terminals U, V, W of the motor.
Otherwise, it maybe damages the devices.
- If the components of the spindle drive units are missed or damaged, don't run it, and contact the agent immediately.
- For the scrapped drive units, its internal electronic components can only be dealt as the industrial waste, which aren't reusable.
Otherwise, the accidents maybe occur.
- Don't turn on or off the input power frequently.
Otherwise, it maybe damages the devices.

CONTENTS

Chapter 1 Outlines	P1
1.1 Introduction	P1
1.2 Performance indices of Servo Drive Units	P1
1.3 Basic structure of AC servo driver	P4
1.4 Checking when received	P4
Chapter 2 Installation	P8
2.1 Installation ambient conditions	P8
2.2 Servo driver installation	P8
2.3 Installation of servo motor	P8
Chapter 3 Wiring	P13
3.1 Main circuit routing	P13
3.2 Main circuit wiring	P14
3.3 Power cables selection	P14
3.4 Feedback signals CN1 and control signals CN2	P15
3.5 Selection of brake resistance	P15
3.6 CN2 routing and Wiring	P17
3.7 CN1 wiring and description	P38
3.8 Connecting and description of communication terminals (CN3,CN4)	P41
Chapter 4 Display and Operation	P42
4.1 Panel operation	P42
4.2 Menu	P44
Chapter 5 Parameters and function	P50
5.1 Parameters definition	P50
5.2 Monitoring states	P52
5.3 Extending parameters	P56
5.4 Basic parameters	P63
5.5 Communication parameters	P66
5.6 Spreading parameters	P68
5.7 Planning table of I/O digital input(DI) function codes	P70
5.8 Planning table of I/O digital output(DO) function codes	P73
5.9 Definition table for servo zero-return mode	P74
5.10 Controlling modes definition table	P77
Chapter 6 Electrification Operation	P80
6.1 Power supply connecting	P80
6.2 Spread trial operation	P82
6.3 JOG running	P83
6.4 Trial operation	P84
6.5 Position mode running	P84
6.6 Speed mode running	P89
6.7 Torque control	P92
6.8 Adjustment	P96

Chapter 7 Alarm and Coping with	P98
7.1 List of Alarm	P98
7.2 Ways to Cope with Alarms	P99
Chapter 8 Communications	P105
8.1 Suitable for the Extent	P105
8.2 Protocol Format	P105
8.3 CRC Verification.....	P107

Chapter1 Outlines

1.1 Introduction

DSL200-P can match with kinds of open loop, semi close loop and close loop control system, and have many special functions such as built-in position control, internal speed control, IO input multi-function plan and so on. It adopts the advanced motor-controlled professional DSP processor and IMP intelligent power module to keep the high integration, small body, good protection and reliable performance. It adopts optimal PID algorithm to finish PWM controlling to make its performance be in the advanced level comparable with the like products.

1.2 Performance indices of Servo Drive Units for DSL200-P

specifications	control mode		Single phase:110V; three phases: 220V full-wave rectification		
			IPM SVPWM control, sinusoidal-wave current drive mode		
	feedback of encoder		General increment type:2500 line resolution.		
			serial communication incremental type: 17 bits		
			serial communication absolute type: 17 bits		
	operation condition		operation/ store temperature	0~+40°C/ -20~+65°C, to make the air circulating much more, when it is above +40°C.	
			operation/ store humidity	below 90% RH (no frost)	
			anti-vibration/ anti-impact strength	4.9m/s ² / 19.6/s ²	
			protection grade	IP10	
			pollution grade	2	
speed, torque control mode		performance		load changing rate	between 0~100% load: below ±0.01% (within rated speed)
				speed changing rate	between 0~100% load: about ±0.01%
				voltage changing rate	about ±10% rated voltage (within rated speed)
				over-current capacity	150% (rated current for 1 minute), 200% (rated current for 5 second)
				temperature changing rate	25±25°C: below ±0.1% (within rated speed)
				speed control range	1:5000
				frequency character	≤800Hz
				torque control precision	±1%
		speed response	no-load	10ms (from 0rpm to rated speed)	

			rated load	100ms (from 0rpm to rated speed)	
		soft-start time setting		0~10s (acceleration and deceleration can be set separately)	
	input signals	speed instruction input	instructing voltage		DC±10V/ rated speed (factory default. It can be adjusted by setting parameters)
			input impedance		input voltage: Max.±12V (positive instruction, the motor rotates forward)
			circuit time constant		about 14kΩ
		torque instruction input	instructing voltage		about 4.7μs
			input impedance		DC±10V/ rated speed (factory default. It can be adjusted by setting parameters)
			circuit time constant		input voltage: Max.±12V (positive instruction, it is the positive torque instruction)
	position control mode	performance	multi-segment internal speed selection		Using signal integration of DI5(SC0)~ DI8(SC3) to realize the speed select of No. 0~15
			instruction smoothness ways		low pass/ S curve smoothly filtering
feed-forward compensation			0~100% (Min. unit is 1%)		
positioning completion width			0~65535 instruction unit (set resolution to be 1 pulse)		
position instruction input		instruction pulse	input pulse status		Pulse + direction; CW/CCW pulse; A/B phase orthogonal pulse
			input form		difference drive integrated electrode open circuit
			input pulse frequency		difference drive: Max. 4Mhz integrated electrode open circuit: Max. 500Khz
			instruction smoothness ways		low-pass filtering / FIR filtering
		control signal		delete signals (input form is same as instruction pulse)	
		built-in integrated electrode open circuit up-pulling resistance		built-in two passes up-pulling to external +24V, 2kΩ resistance	
	internal multi-segment position control		Using signal integration of DI5(SC0)~ DI8(SC3) to realize the speed select of No. 0~15		
	raster ruler instruction input	feed-forward compensation		0~100% (Min. unit is 1%)	
positioning completion width		0~65535 instruction unit (set resolution to be 1 pulse)			
instruction pulse		input form		difference drive	
		input pulse frequency		difference drive: Max. 4Mhz; integrated electrode open circuit: Max. 500Khz	
		smoothness filtering		low-pass filtering / FIR filtering	

	position feedback output	input form	phase A, phase B, phase Z; difference drive output
		frequency dividing ratio	arbitrarily
	digital input signals	signal input functional planning can be done	pass 9 DI input servo start; to remove the abnormal alarm; stop internal speed dictation temporarily; drive prohibition; external torque limitation; zero speed embedding; internal speed dictation selecting; control mode switching; position dictation prohibition; position gain switching; the numerator selection of the electron gear ratio; internal position dictation triggering; stop internal position dictation temporarily; zero-return function triggering; emergency stop etc.
digital output signals	signal output functional planning can be done	pass 5 DO output servo be ready for; motor be rotating; zero-speed signal; speed reaching; position reaching; positioning proximity signal; torque being limited; speed being limited; brake signal output; servo alarm signal output etc.	
built-in functions	Overrun (OT) prevention function		Positive -OT, negative -OT, speed reduces until stop
	PID parameters self-adjusting		16 grades adjusting
	origin-zero-return function for various machines		origin-return way of various machines
	electron gear ratio		$1/1000 \leq N/M \leq 1000$
	electron gear cam		undetermined
	regenerated brake	brake mode	energy-consumed brake
		brake resistance	built-in or external
	protection function		over-/under- position, over-speed, over-/under- voltage of main circuit, power module failures, abnormal brake return circuit, over-current, over-load, encoder signals interference, encoder broken wire, motor type set wrongly, abnormal control power supply, E2PROM abnormality etc.
	monitoring function		motor speed, present position pulse position instruction pulse amount, position deviation, motor torque, linear velocity, rotor absolute position, instruction pulse frequency, motor current, running status, I/O terminal signals status, present given voltage, servo alarm memory etc.
	communication function		Can bus, RS232, RS485, adopts ModBus agreement.
display and operation		5 bits LED Nixie tube; 4 buttons	

1.3 Basic structure of AC servo driver

Basic structure of AC driver is shown as the following.

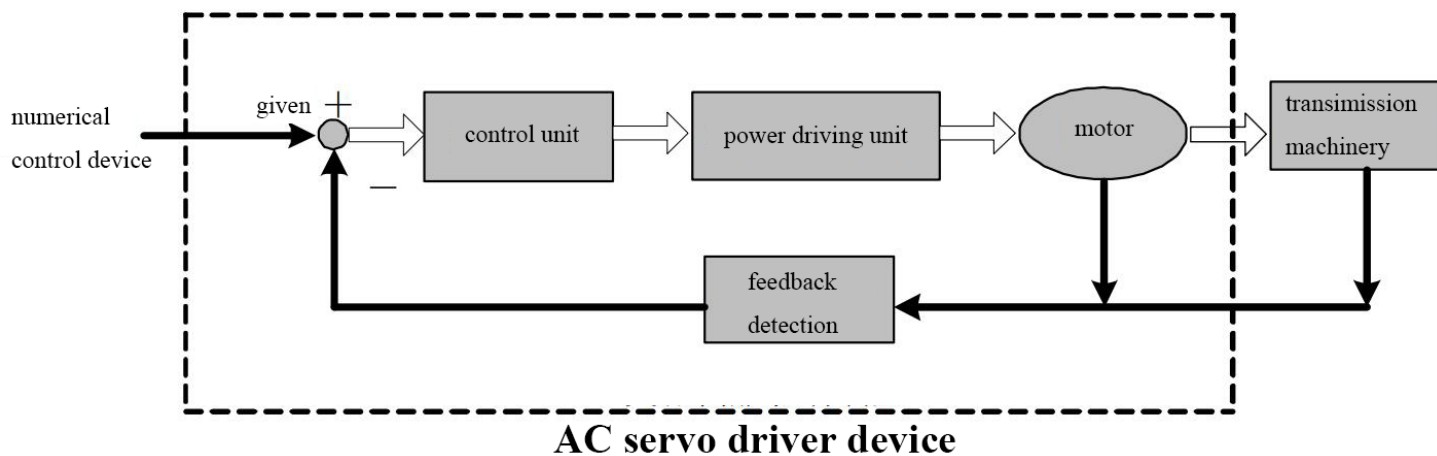

1.4 Checking when received

1.4.1 Please check the followings when received

- ◆ Whether the packing and products are well during the transportation?
- ◆ Check the labels whether they are in accord with what you ordered?
- ◆ Check the packing list whether all accessories are there?

Notes

- For damaged or lacking of parts servo motor and servo driver, they can't be installed.
- Servo driver should be used with the matched servo motor.
- If having any questions, please tell us.

1.4.2 Motor type description

DSL200P servo driver can match with kinds of servo motor with 2500 line encoder. Customers can select when ordering.

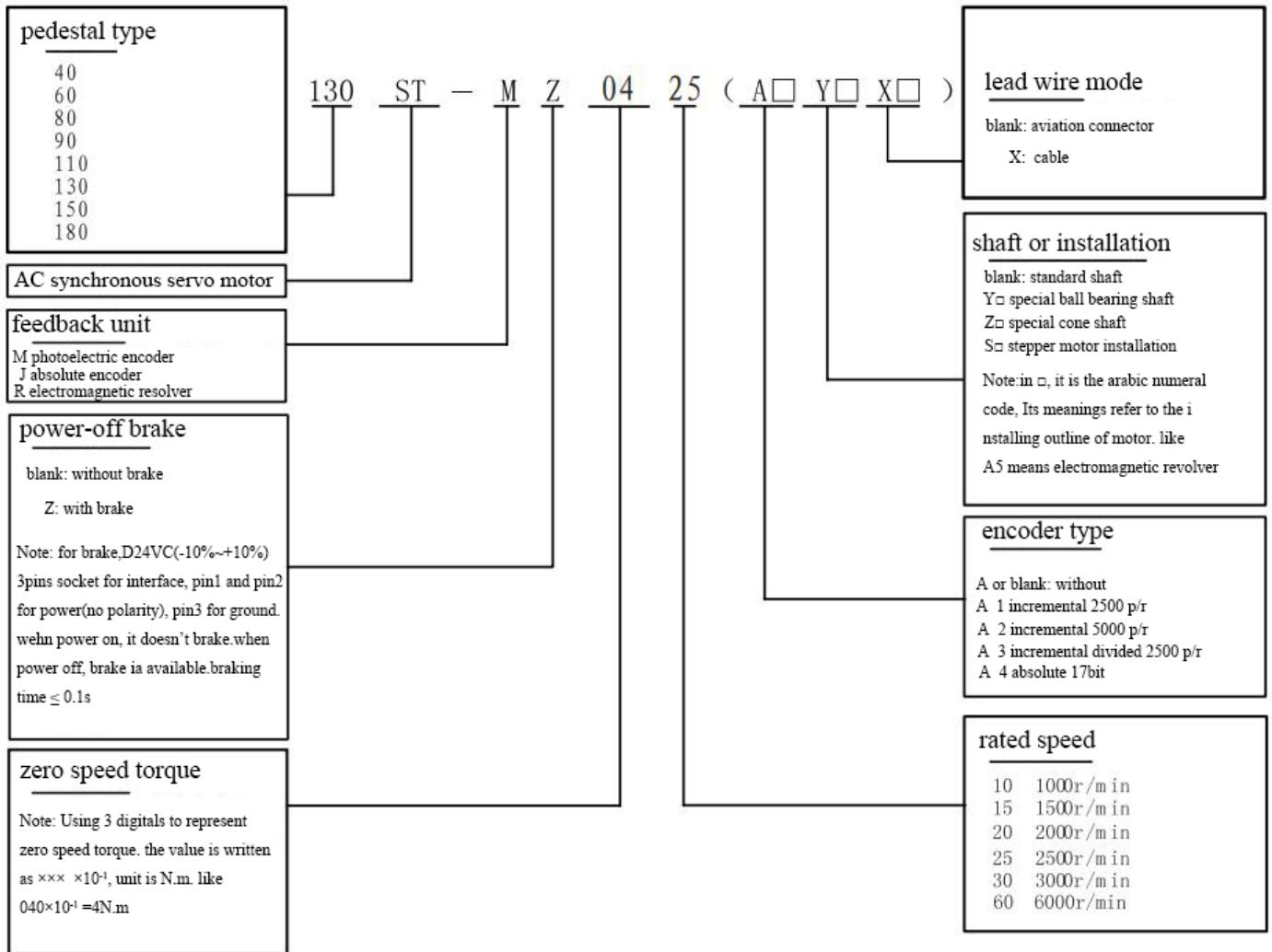

1.4.3 Ordering type description

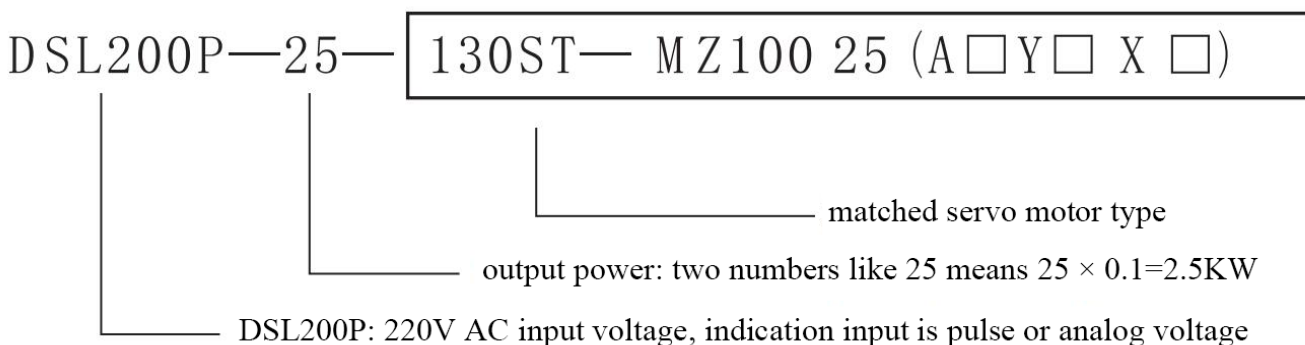

The matched servo motor with absolute encoder for DSL200P series are shown in the following table for reference.

servo driver model	matched servo motor	motor flange	rated power	rated current	rated torque	rated speed
DSL200P-01	40ST-M00330	40mm	100W	0.8A	0.31N.m	3000rpm
DSL200P-01	60ST-M00330	60mm	100W	0.8A	0.31N.m	3000rpm
DSL200P-02	60ST-M00630	60mm	200W	1.5A	0.637N.m	3000rpm
DSL200P-04	60ST-M01330	60mm	400W	2.8A	1.27 N.m	3000 rpm
DSL200P-06	60ST-M01930	60mm	600W	3.5A	1.91 N.m	3000 rpm
DSL200P-04	80ST-M01330	80mm	400W	2.0A	1.27 N.m	3000 rpm
DSL200P-07	80ST-M02430	80mm	750W	3.0A	2.4 N.m	3000 rpm
DSL200P-07	80ST-M03520	80mm	730W	3.0A	3.5 N.m	2000 rpm
DSL200P-10	80ST-M04025	80mm	1KW	4.4A	4.0 N.m	2500 rpm
DSL200P-07	90ST-M02430	90mm	750W	3.0A	2.4 N.m	3000 rpm
DSL200P-07	90ST-M03520	90mm	750W	3.0A	3.5 N.m	2000 rpm
DSL200P-10	90ST-M04025	90mm	1KW	4.0A	4.0 N.m	2500 rpm
DSL200P-06	110ST-M02030	110mm	600W	2.5A	2.0 N.m	3000 rpm
DSL200P-08	110ST-M04020	110mm	800W	3.5A	4.0 N.m	2000 rpm
DSL200P-12	110ST-M04030	110mm	1.2KW	5.0A	4.0 N.m	3000 rpm
DSL200P-15	110ST-M05030	110mm	1.5KW	6.0A	5.0 N.m	3000 rpm
DSL200P-12	110ST-M06020	110mm	1.2KW	4.5A	6.0 N.m	2000 rpm
DSL200P-18	110ST-M06030	110mm	1.8KW	6.0A	6.0 N.m	3000 rpm
DSL200P-10	130ST-M04025	130mm	1.0KW	4.0A	4.0 N.m	2500 rpm
DSL200P-13	130ST-M05025	130mm	1.3KW	5.0A	5.0 N.m	2500 rpm
DSL200P-15	130ST-M06025	130mm	1.5KW	6.0A	6.0 N.m	2500 rpm
DSL200P-20	130ST-M07725	130mm	2.0KW	7.5A	7.7 N.m	2500 rpm
DSL200P-10	130ST-M10010	130mm	1.0KW	4.5A	10.0 N.m	1000 rpm
DSL200P-15	130ST-M10015	130mm	1.5KW	6.0A	10.0 N.m	1500 rpm
DSL200P-26	130ST-M10025	130mm	2.6KW	10.0A	10.0 N.m	2500 rpm
DSL200P-23	130ST-M15015	130mm	2.3KW	9.5A	15.0 N.m	1500 rpm
DSL200P-38	130ST-M15025	130mm	3.8KW	13.5A	15.0 N.m	2500 rpm
DSL200P-27	180ST-M17215	180mm	2.7KW	10.5	17.2 N.m	1500 rpm
DSL200P-30	180ST-M19015	180mm	3.0KW	12.0	19 N.m	1500 rpm
DSL200P-45	180ST-M21520	180mm	4.5KW	16.0	21.5 N.m	2000 rpm
DSL200P-29	180ST-M27010	180mm	2.9KW	12.0	27.0 N.m	1000 rpm
DSL200P-43	180ST-M27015	180mm	4.3KW	16.0	27.0 N.m	1500 rpm
DSL200P-37	180ST-M35010	180mm	3.7KW	16.0	35.0 N.m	1000 rpm
DSL200P-55	180ST-M35015	180mm	5.5KW	19.0	35.0 N.m	1500 rpm
DSL200P-75	180ST-M48015	180mm	7.5KW	32.0	48.0 N.m	1500 rpm
DSL200P-55	180ST-M23825	180mm	5.5KW	19.7	23.8 N.m	2000 rpm

Notes:

- For the rated speed with 6000rpm, only 60mm flange servo motor can match it here.

1.4.4 Accessories

order type	pulse/analog indication interface model	remarks
drive device (servo driver, servo motor)	① 1 DSL200P AC servo driver manual. ② 1set 3M servo driver plug cable (3M-50). ③ one 3m motor cable and 3m encoder cable (3M-20)	cables are welded well
drive device matched for CNC (servo driver, servo motor, CNC)	① 1 DSL200P AC servo driver manual. ② one 3m motor cable and 3m encoder cable (3M-20) ③ 3M signals control cable from system to servo driver	

Notes:

- For position control servo driver, there has 3M standard signals cable.
- For servo motor, if needing, we can also provide 3M standard feedback cable.
- Standard accessories for servo motor will be provided according to the above table.

Chapter 2 Installation

Notes

- Storage and installation must meet with the ambient condition requirements.
- Storage and transportation must use original package.
- The damaged and parts lacked driver and motor can't be installed and used.
- Fire-proof materials should be used for installation. It can't be installed above or near to combustibles to avoid the fire.
- Servo driver should be installed inside the control cabinet to prevent from dust, corrosive gases, conductive objects, liquid and combustibles
- Servo driver and servo motor should avoid vibration, prohibit shock
- To prohibit to drag the cables of servo driver, servo motor and encoder. Don't drag the shaft.

2.1. Installation ambient conditions

Item	DSL200P servo driver	the matched AC servo motor with DSL200P series
usage temperature/humidity	-10℃ ~ +80℃ (no frost) below 90%RH (no condensation)	-10℃ ~ +40℃ (no frost) below 90%RH (no condensation)
air condition	inside control cabinet, no corrosive gas, combustive gas, oil mist, dust and so on.	no solarization, corrosive gas, combustive gas, oil mist, dust and so on.
standard altitude height	below 1000m	below 1000m
vibration	less than 0.5G(4.9m/s ²) 10~60Hz(discontinuous operation)	less than 0.5G(4.9m/s ²) 10~60Hz(discontinuous operation)
protection level	IP43	IP65

2.2. Servo driver Installation

2.2.1. Installing ambient

2.2.1.1. Protection

There are no protection for servo driver's self structure. It should be installed inside the good protective electric cabinet to avoid contacting the corrosive combustive gas, conductive objects, metal powder, oil mist and liquid.

2.2.1.2. Temperature and humidity

Ambient temperature is between 0°C~+50°C. Below 45°C are recommended for long running, and make it in the good heat dissipation condition.

2.2.1.3. Vibration and shock

Servo driver should avoid vibration. It is recommended taking vibration proof to control it below 0.5G (0.49m/s²). Driver also needs to avoid heavy load and shock.

2.2.2. Installation

2.2.2.1. Installation way of DSL200P

Bottom plate installation or panel installation is the recommended way. the direction is vertical to the installation surface.

2.2.2.2. Installation dimension

◆ Outline dimension A (unit: MM)

Single phase/ three phase 220V:0.4KW-0.75KW

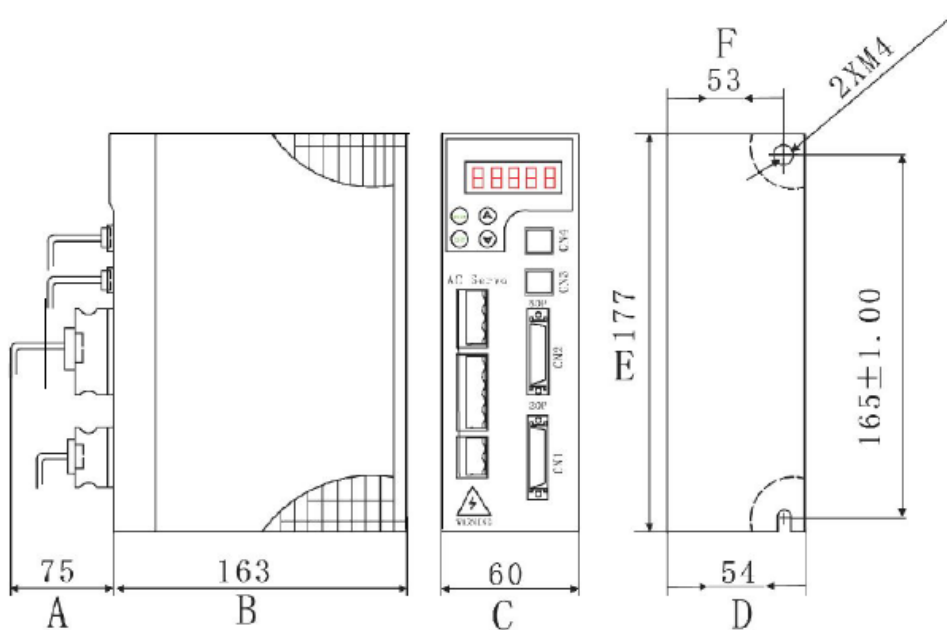

Type	Weight(kg)	A(mm)	B(mm)	C(mm)	D(mm)	E(mm)	F(mm)	G(mm)
0.4KW-0.75KW	1.10 ± 0.05	75	163	60	54	177	53	165 ± 1.00

◆ Outline dimension B (unit: MM)

Single phase/ three phase 220V:1.0KW-2.0KW; 2.3KW-4.0KW

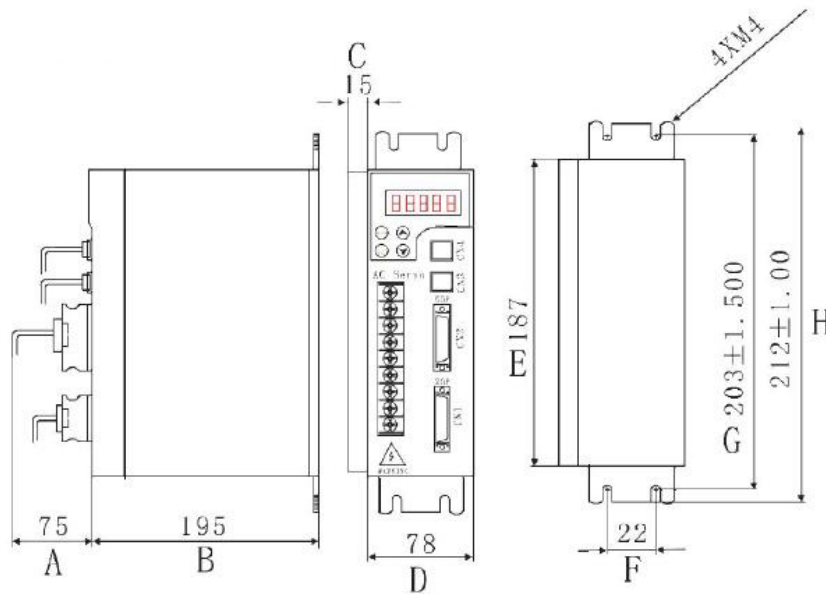

Type	Weight(kg)	A(mm)	B(mm)	C(mm)	D(mm)	E(mm)	F(mm)	G(mm)	H(mm)
1.0KW-2.0KW	2.00 ± 0.05	75	195	15	78	187	22	203 ± 1.5	212 ± 1.00
2.3KW-4.0KW	2.20 ± 0.05	75	195	15	78	187	22	203 ± 1.5	212 ± 1.00

2.2.2.3. Installation interval of DSL200P

The installation interval of signal driver is referred as below.

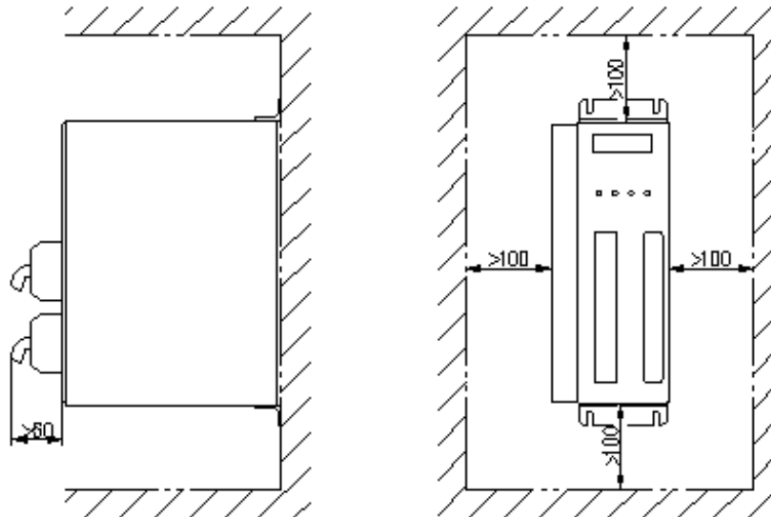

The installation intervals of multi servo drivers is referred as below. Please leave enough room in actual installation to provide good heat dissipation.

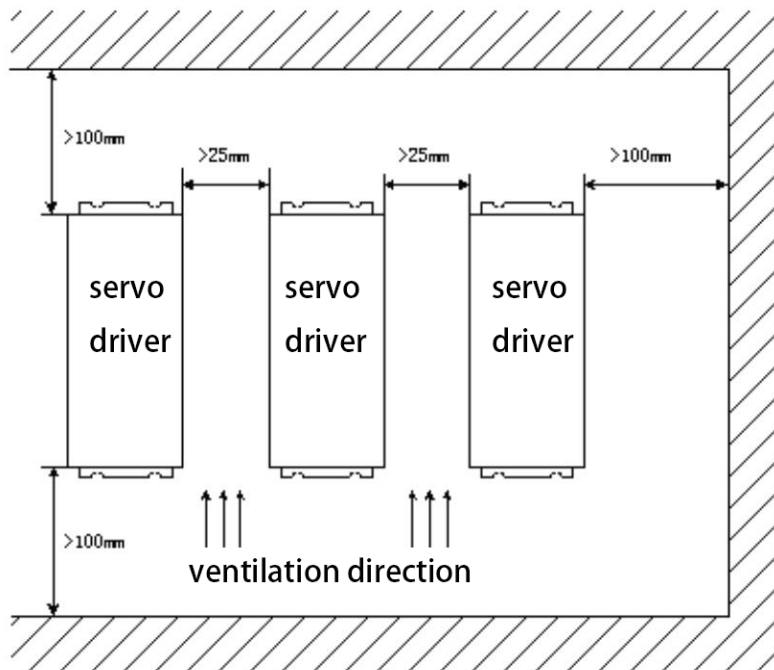

2.2.2.4. Heat dissipation

To avoid around temperature rising continuously, there needs convection wind blowing to driver radiator in electric cabinet.

2.3. Installation of servo motor

2.3.1. Installation conditions

2.3.1.1. Protection

Up to now, DSL200P series servo motor isn't waterproof. When installing, must avoid liquid splashing on servo motor, must avoid oil entering into the motor along wires and shaft.

Notes

- If you need waterproof servo motor, please tell me when ordering.

2.3.1.2. Temperature and humidity

Ambient temperature should keep $-10^{\circ}\text{C}\sim+40^{\circ}\text{C}$. Motor will heat to lead to temperature rising in long running. when the room is small or other heating equipment is nearby, forced heat dissipating should be considered. Humidity should be less than 90%RH, no frost.

2.3.1.3. Vibration

Servo motor should avoid vibration. Vibration should be no more than 0.5G (4.9m/s^2).

2.3.2. Installation

2.3.2.1. Installation way

At present, ST series servo motor can adopt flange mounting with arbitrary direction.

2.3.2.2. Notes

- When dismantling band pinion, no knocking to motor or motor shaft avoid damaging encoder. Suggesting to use helical pressing-pulling tools dismantling it.
- Until now, most ST series servo motor can't bear much axial load and radial load. Suggesting to select springy couplers to connect load.
- When fastening motor, the anti-loosing gaskets are needed to avoid the motor getting loose.
- The place where servo motor is installed in must be waterproof and oil-proof. If cables are immersed into water or oil, water or oil maybe enters into the motor.

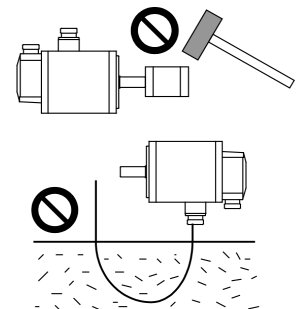

Chapter 3 Wiring



WARNING

- Driving power supply of this series is AC single phase or three phase 220V, the running power supply of driver must be checked before wiring.
- User must consider the secure protection measurement during the design and installation of the series so as to prevent the accidental event from the incorrect operation.
- Driver terminals U, V, W must connect motor terminal U, V, W correspondingly.
- Both driver and motor must ground well.
- Driver must be cut off the power for over 5 minutes before user dismantles it so as to avoid electric shock.
- Don't open/ close the power supply frequently. Please operate it one time within 1 minute if needed.

3.1. Main circuit routing

3.1. 1. Main circuit wiring definition table of 1KW~3.8KW driver

Terminals code	Name	Description
R	main circuit power supply single phase or three phase	to connect power supply single phase/ three phase (To select suitable voltage specification according to driver type, only needs to connect R and S single phase 220V, 50/60Hz)
S		
T		
PE	grounded protecting terminal	to connect the grounding terminals of the power supply and motor
U	motor power connecting terminals	to connect the motor, must keep the accordance with motor terminals U, V, W.
V		
W		
R	control power supply (single phase)	control return-circuit power supply input terminal, 220V, 50/60Hz
S		

3.1. 2. Main circuit wiring definition table of 100W~750W driver

Terminals code	Name	Description
R	main circuit power supply single phase or three phase	to connect power supply single phase/ three phase (To select suitable voltage specification according to driver type, only needs to connect R and S single phase 220V, 50/60Hz)
S		
PE	grounded protecting terminal	to connect the grounding terminals of the power supply and motor

PE	motor grounded terminal	
U	motor power connecting terminals	to connect the motor, must keep the accordance with motor terminals U,V, W.
V		
W		

3.2. Main circuit wiring

3.2.1. Single phase power supply wiring

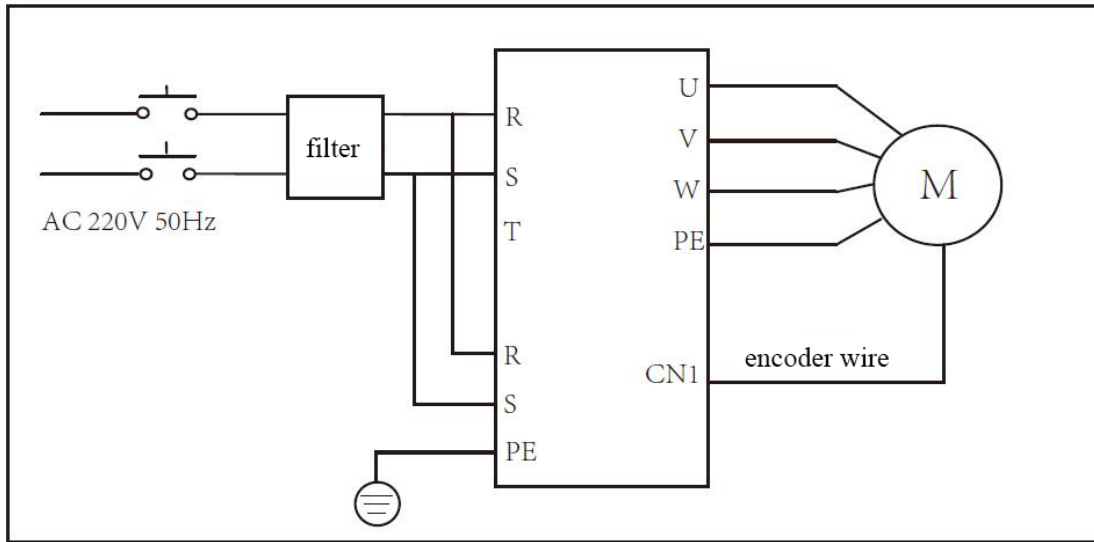

3.2.2. Three phase power supply wiring

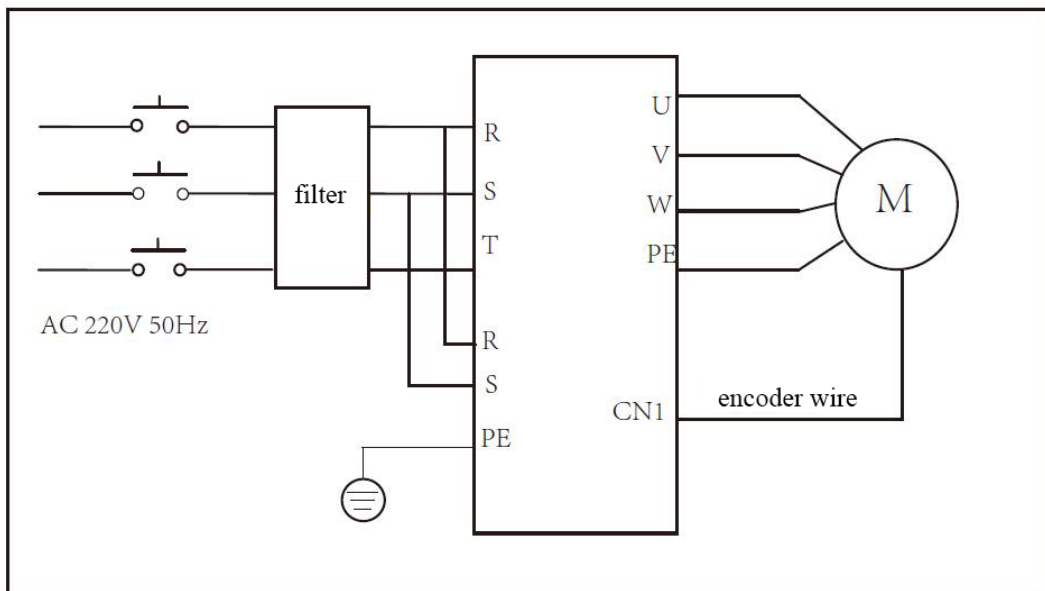

3.3. Power cables selection

◆0.1~0.75KW: for terminal R, S, FG, U, V, W, line cross-sectional areas $\geq 1.5\text{mm}^2$ (AWG14-16), for terminal r, s, line cross-sectional areas $\geq 1.0\text{mm}^2$ (AWG16-18) .

- ◆ 0.8~1.5KW: for terminal R, S, FG, U, V, W, line cross-sectional areas $\geq 2\text{mm}^2$ (AWG14-16) , for terminal r, s, line cross-sectional areas $\geq 1.0\text{mm}^2$ (AWG16-18) .
- ◆ 1.8~3KW: for terminal R, S, FG, U, V, W, line cross-sectional areas $\geq 2.5\text{mm}^2$ (AWG14-16) , for terminal r, s, line cross-sectional areas $\geq 1.0\text{mm}^2$ (AWG16-18) .
- ◆ 3.2~7.5KW: for terminal R, S, FG, U, V, W, line cross-sectional areas $\geq 4\text{mm}^2$ (AWG14-16) , for terminal r, s, line cross-sectional areas $\geq 1.0\text{mm}^2$ (AWG16-18) .
- ◆ Ground, the ground wire should be a little rough as possible. both driver and motor ground at terminal PE.
ground resistance $< \Omega$.
- ◆ Terminals need to adopt SVM2-4 pre-insulated cold pressed technology. They should connect firmly.
- ◆ Three phase isolation transformer is recommended to reduce the possibility of person's hurt by electric shock.
- ◆ Noise filter for power supply is recommended to heighten anti-interference.
- ◆ Please install non-fuse broken circuit breaker to make driver cut off external power when failures occurred.

3.4. Feedback signals CN1 and control signals CN2

- ◆ Cable material: please select the double-twisted shielded cable (the copper double-twisted shielded cable is best). Section area of cable $\geq 0.15\text{mm}^2$ (AWG24-26) . shielded layer must connect the FG ports.
- ◆ Cable length: it should be short as possible. Control cable CN2 is no more than 3m. Feedback signal cable CN1 is no more than 20m.
- ◆ Wiring: to wire it far away from power supply cable so as to prevent the cross-line interference.
- ◆ Please install the surge absorption elements for inductive parts (coils) in related circuits. DC coils reversely parallel freewheeling diode, AC coils parallel resistance absorption loop.

3.5. Selection of brake resistance

servo driver	brake resistance			
	resistance	power	resistance cover	access mode
1.0Kw~4.3Kw	80Ω	200W	aluminum shell	built-in
4.5Kw~7.5Kw	80Ω	800W~ 2KW	aluminum shell or ceramics	external

Notes: brake resistance selection should be based on load inertia, running speed, time of acceleration or deceleration. The suitable resistance should be chosen according to real application condition.

Notes:

- Wiring should be done by professional person. And connect correctly according to the related description.
- Wiring and checking operation should be done, after driver cutting off power more than 5 minutes and confirming that the ground voltage of each main circuit is safe by multimeter, otherwise electric shock maybe occurs.
- Please confirm driver and motor ground correctly.
- When wiring, don't damage the cable with sharp objects, don't pull the cable hard, otherwise electric shock or bad wire contact maybe happen.
- Don't make the main return-circuit wire and signal cable together pass through the same tube, also don't bind them together. The main return-circuit wire and signal cable should be wired dividedly or crosswise , and the distance keeps away over 30cm, to prevent the interference in signal cable from strong electric wire, to ensure the drive unit to be in good condition.
- Don't turn on/off power supply frequently, if doing it, there will have much charging current owing to the large capacity capacitance inside the driver, which will decline the internal parts performance of driver. The interval time between being on and off is recommended more than 3 minutes for each time.
- Don't add power capacity, surge absorbers and radio noise filters between the output side of the drive units and servo motor.
- To make the main return-circuit wire and signal cable keep away from the radiator and motor so not decline the insulation performance due to heating. After finishing the main return-circuit connecting, the cap of terminals must be covered to avoid the electric shock.



- Both main return circuit wires and signals wires should far away from heat dissipation device and servo motor so as to avoid declining insulation performance affected by heat.
- After finishing the main return circuit connection, terminal protection caps should be covered to avoid electric shock.

3.6. CN2 routing and wiring

3.6.1. CN2 ports definition table

Pin No.	Pin symbol	Symbol content	Remarks
43	COM+	external power+24V	
18	COM+		
6	COM-	external power 0V	
31	COM-		
38	SON	servo enable	I/O input 1

11	CCWL	CCW prohibition	I/O input 2
12	CWL	CW prohibition	I/O input 3
17	FIL	CCW torque limitation	I/O input 4
14	RIL	CW torque limitation	I/O input 5
15	ENGS	servo emergency stop	I/O input 6
10	SC0	switch select 0	I/O input 7
13	SC1	switch select 1	I/O input 8
19	SC2	switch select 2	I/O input 9
32	SPDY+	be ready signal	I/O output 1
7	SPDY-	be ready signal ground	
34	ALAM+	servo alarm output signal	I/O output 2
9	ALAM-	servo alarm output signal ground	
30	ZSPD+	Positioning finish signal	I/O output 3
5	ZSPD-	Positioning finish signal ground	
4	TSPD+	speed reaching signal	I/O output 4
28	TSPD-	speed reaching signal ground	
27	BRKR+	electromagnetic brake signal	I/O output 5
26	BRKR-	electromagnetic brake signal ground	
8	CZ+	Z-phase output signal	I/O output 6
33	CZ-	Z-phase output signal ground	
49	PULSE	instruction pulse input signal	
50	/PULSE	instruction pulse input signal ground	
25	SIGN	instruction pulse direction input signal	
24	/SIGN	instruction pulse direction input signal ground	
29	RP1	internal up-pull 2K resistance port1	
16	RP2	internal up-pull 2K resistance port2	
3	V-REF	speed analog instruction voltage input	
2	AGND	external analog instruction voltage low	
1	T-REF	torque analog instruction voltage input	
46	PAOUT+	Servo encoder pulse feedback A+	
20	PAOUT-	Servo encoder pulse feedback A-	
23	PBOUT+	Servo encoder pulse feedback B+	
48	PBOUT-	Servo encoder pulse feedback B-	
21	PZOUT+	Servo encoder pulse feedback Z+	
22	PZOUT-	Servo encoder pulse feedback Z-	

47	GND	servo internal digital ground	
45	GND		

3.6.2. Detailed description of control signal terminals

terminal No.	signal name	symbol	I/O	mode	function								
CN2-43	positive polar of input power terminal	COM+	positive polar of external power		to use the positive polar of input power terminal to drive the photo-coupler of input terminal, DC12V~24V, current \geq 100mA								
CN2-38	servo start	SON	TYPE1	P S	servo enable input terminal SON ON: allow the drive to work SON OFF: driver cease, stop working, motor be free. Notice 1: before switching from SON OFF to SON ON, motor must be static; Notice 2: after turn to SON on, at least need to wait for 50ms, then input the command again.								
CN2-11	CCW drive prohibition	CCWL	TYPE1	P S	CCW drive prohibiting input terminal CCWL ON: CCW drive permit CCWL OFF: CCW drive prohibition Notice 1: for machine overrun, when the switch is "OFF", CCW torque keeps "0" Notice 2:the shielded function can be done by setting parameters P1-52, or let the switch keep in the "ON"								
CN2-12	CW drive prohibition	RSTP	TYPE1	P S	CW drive prohibiting input terminal CWL ON: CW drive permit CWL OFF: CW drive prohibition Notice 1: for machine overrun, when the switch is "OFF", CW torque keeps "0" Notice 2:the shielded function can be done by setting parameters P1-52, or let the switch keep in the "ON"								
CN2-10	select switch 0	SC0	TYPE1	P S	input terminal for internal position or speed select. Such as in the mode of speed control, using the combination of SC2/ SC1/ SC0 to select different internal speed.								
CN2-13	select switch 1	SC1	TYPE1	P S									
CN2-19	select switch 2	SC2	TYPE1	P S									
					<table border="1"> <tr> <td>SC2</td> <td>SC1</td> <td>SC0</td> <td>speed select</td> </tr> <tr> <td>OFF</td> <td>OFF</td> <td>OFF</td> <td>analog instruction</td> </tr> </table>	SC2	SC1	SC0	speed select	OFF	OFF	OFF	analog instruction
SC2	SC1	SC0	speed select										
OFF	OFF	OFF	analog instruction										

					<table border="1"> <tbody> <tr> <td>OFF</td> <td>OFF</td> <td>ON</td> <td>internal speed 1</td> </tr> <tr> <td>OFF</td> <td>ON</td> <td>OFF</td> <td>internal speed 2</td> </tr> <tr> <td>OFF</td> <td>ON</td> <td>ON</td> <td>internal speed 3</td> </tr> <tr> <td>ON</td> <td>OFF</td> <td>OFF</td> <td>internal speed 4</td> </tr> <tr> <td>ON</td> <td>OFF</td> <td>ON</td> <td>internal speed 5</td> </tr> <tr> <td>ON</td> <td>ON</td> <td>OFF</td> <td>internal speed 6</td> </tr> <tr> <td>ON</td> <td>ON</td> <td>ON</td> <td>internal speed 7</td> </tr> </tbody> </table>	OFF	OFF	ON	internal speed 1	OFF	ON	OFF	internal speed 2	OFF	ON	ON	internal speed 3	ON	OFF	OFF	internal speed 4	ON	OFF	ON	internal speed 5	ON	ON	OFF	internal speed 6	ON	ON	ON	internal speed 7
OFF	OFF	ON	internal speed 1																														
OFF	ON	OFF	internal speed 2																														
OFF	ON	ON	internal speed 3																														
ON	OFF	OFF	internal speed 4																														
ON	OFF	ON	internal speed 5																														
ON	ON	OFF	internal speed 6																														
ON	ON	ON	internal speed 7																														
CN2-17	CCW torque limitation	FIL	TYPE1	P S	CCW torque limitation input terminal FIL ON: CCW torque be limited in the range of parameter P4-10 FIL OFF: CCW torque be not limited in the range of parameter P4-10																												
CN2-14	CW torque limitation	RIL	TYPE1	P S	CW torque limitation input terminal RIL ON: CW torque be limited in the range of parameter P4-11 RIL OFF: CW torque be not limited in the range of parameter P4-11																												
CN2-15	emergency stop	EMGS	TYPE1	P S	ON: emergency stop servo driver. If want to make servo work again, please re-power OFF: servo can work normally.																												
CN2-32 CN2-7	servo be ready for output	SRDY+ SRDY-	TYPE1	P S	servo be ready for output terminal SRDY ON: be normal for control power and main power, no alarm for driver, servo be ready for output is ON. SRDY OFF: be abnormal for main power, alarms for driver, servo be ready for output is OFF.																												
CN2-34 CN2-9	servo alarm output	ALRM+ ALRM-	TYPE1	P S	servo alarm output terminal ALM ON: no alarms for servo driver, servo alarm output is ON ALM OFF: alarms for servo driver, servo alarm output is OFF																												
CN2-30 CN2-5	positioning finish output	ZSPD+ ZSPD-	TYPE1	P S	when the position feedback deviation of motor less than the setting value of parameter P1-36, ZSPD signal output is ON																												
CN2-4 CN2-28	speed reach output	TSPD+ TSPD-	TYPE1	P S	when the real speed (r/m in) more than the setting value of parameter P1-37, TSPD signal output is ON																												
CN2-27 CN2-26	electromagnetic brake signal output	BRKR+ BRKR-	TYPE1	P S	control module of motor brake open or close, missing polar open circuit output, when work normally, optical coupling breakover, output is ON; no enable, drive prohibition, alarming, optical coupling cut-off, output is OFF.																												

CN2-8 CN2-33	encoder Z phase output	CZ+ COM-	TYPE1	P S	encoder Z phase output terminal photoelectric encoder Z phase pulse output of servo motor. CZ ON: Z phase signal appears
CN2-45	servo drive internal digital ground	GND	servo drive internal ground		if there are much interference in external input, can make external 24V power ground and servo drive internal digital ground be in short connection
CN2-49 CN2-50	instruction pulse input (PULS)	PULS /PULS	TYPE3	P	external instruction pulse input terminal Notice1: pulse input mode is set by the parameter P1-03 instruction pulse + symbol mode
CN2-25 CN2-24	instruction pulse input (SIGN)	SIGN /PULS	TYPE3	P	CCW/CW instruction pulse mode A/B phase instruction pulse mode
CN2-2	analog ground	AGND	external analog voltage ground	S T	speed/ torque analog voltage instruction ground
CN2-3	speed input analog instruction	V-REF	TYPE4	S	input analog instruction -10V∞+10V input resistance 20K
CN2-1	torque input analog instruction	T-REF	TYPE4	T	input analog instruction -10V∞+10V input resistance 20K
CN2-46 CN2-20 CN2-23 CN2-48 CN2-21 CN2-22	phase A+ pulse phase A- pulse phase B+ pulse phase B- pulse phase Z+ pulse phase Z- pulse	PAOUT+ PAOUT- PBOUT+ PBOUT- PZOUT+ PZOUT-	TYPE5	PST PST PST PST PST PST	encoder feedback output signal, 2500P/r one turn, one pulse

Notes: TYPE1:single-terminal drive input; TYPE3:difference signal input;

TYPE4:external analog amount input; TYPE5:servo double-terminal drive input.

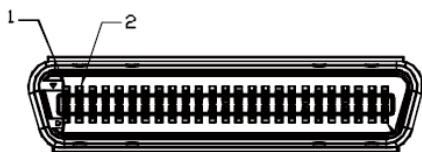

the front view of CN2 twiring terminals

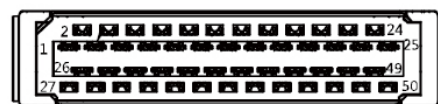

the back view of CN2 twiring terminals

3.6.3. CN2 wiring diagram

3.6.3. 1.Position control mode (pulse mode)

A: The pulse voltage of host computer is 5V, when the host computer is a numerical control system or a motion control card.

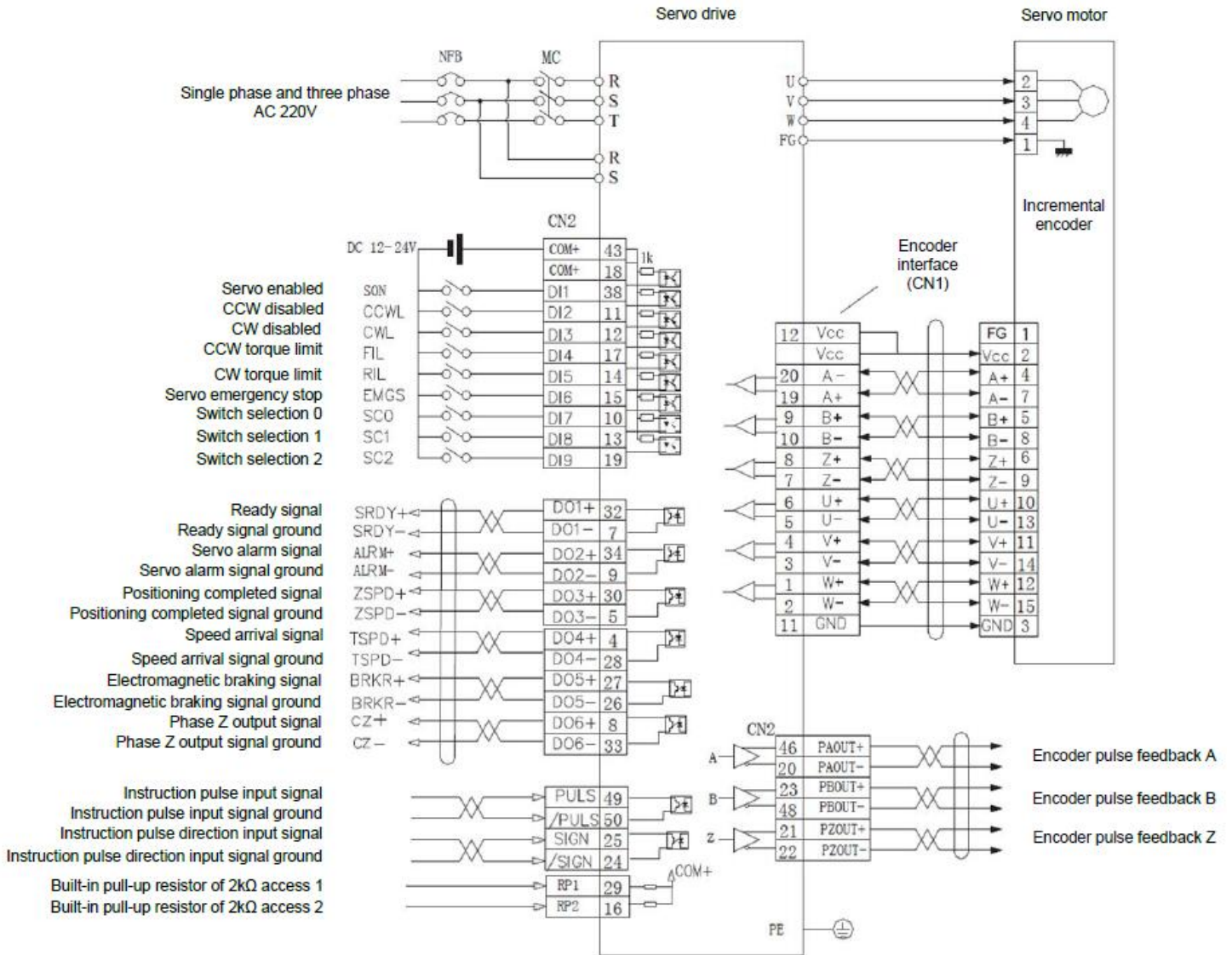

DSL200-P position control (pulse mode) standard connecting

B: The pulse voltage of master computer is 24V, when the host computer is PLC control

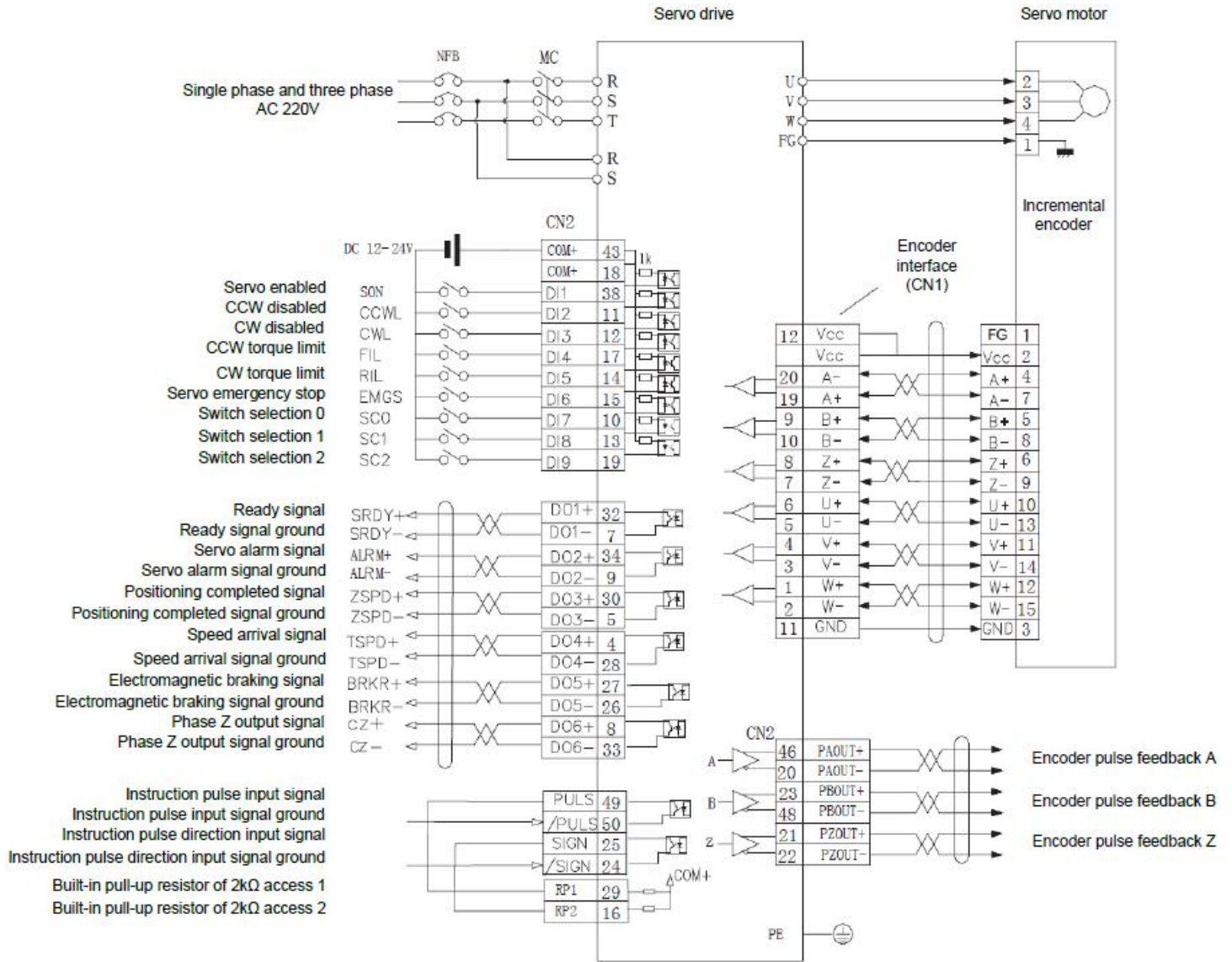

DSL200-P position control (pulse mode) standard connecting

3.6.3. 2.Speed control mode (analog voltage)

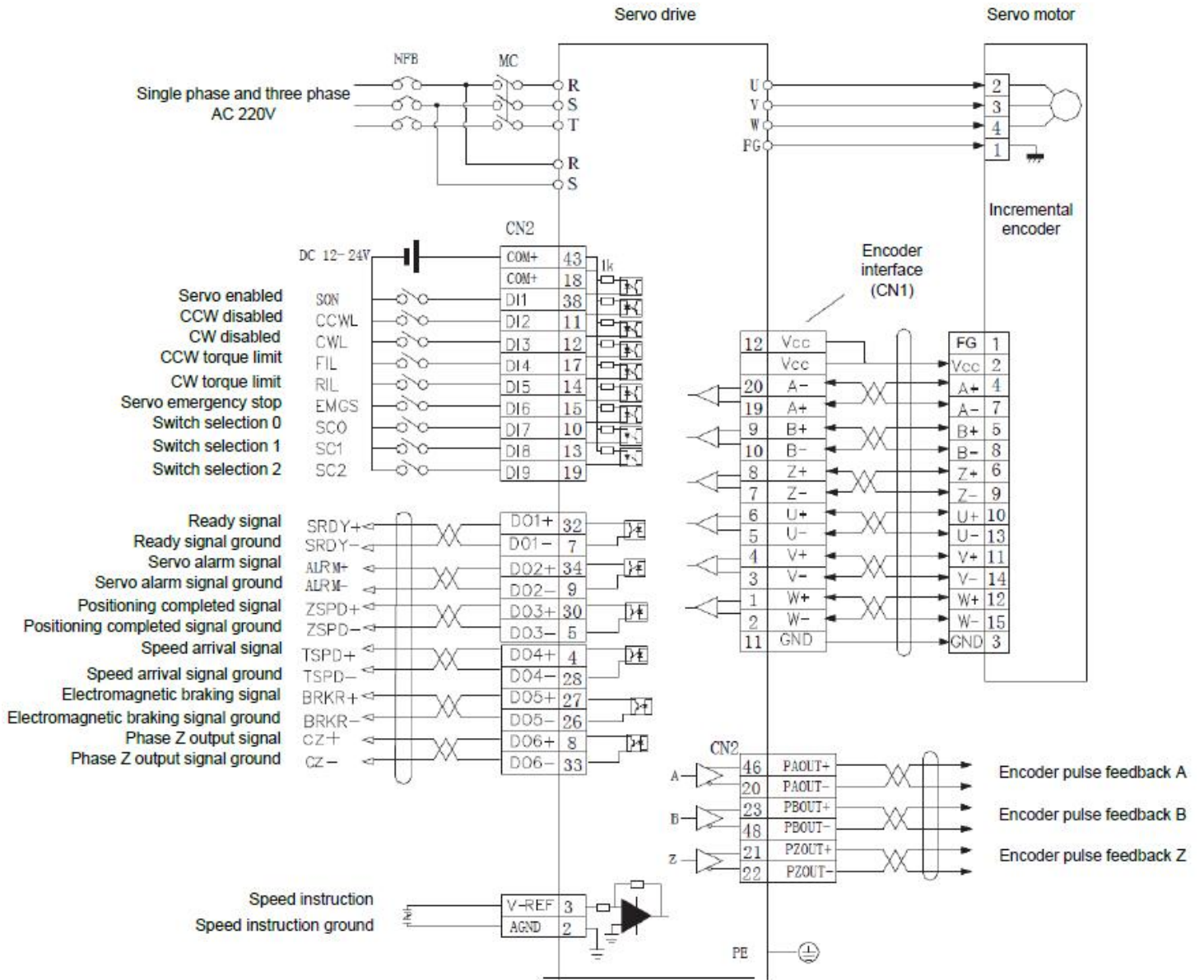

DSL200-P speed control (analog voltage mode) standard connecting

3.6.3. 3.Torque control mode (analog voltage)

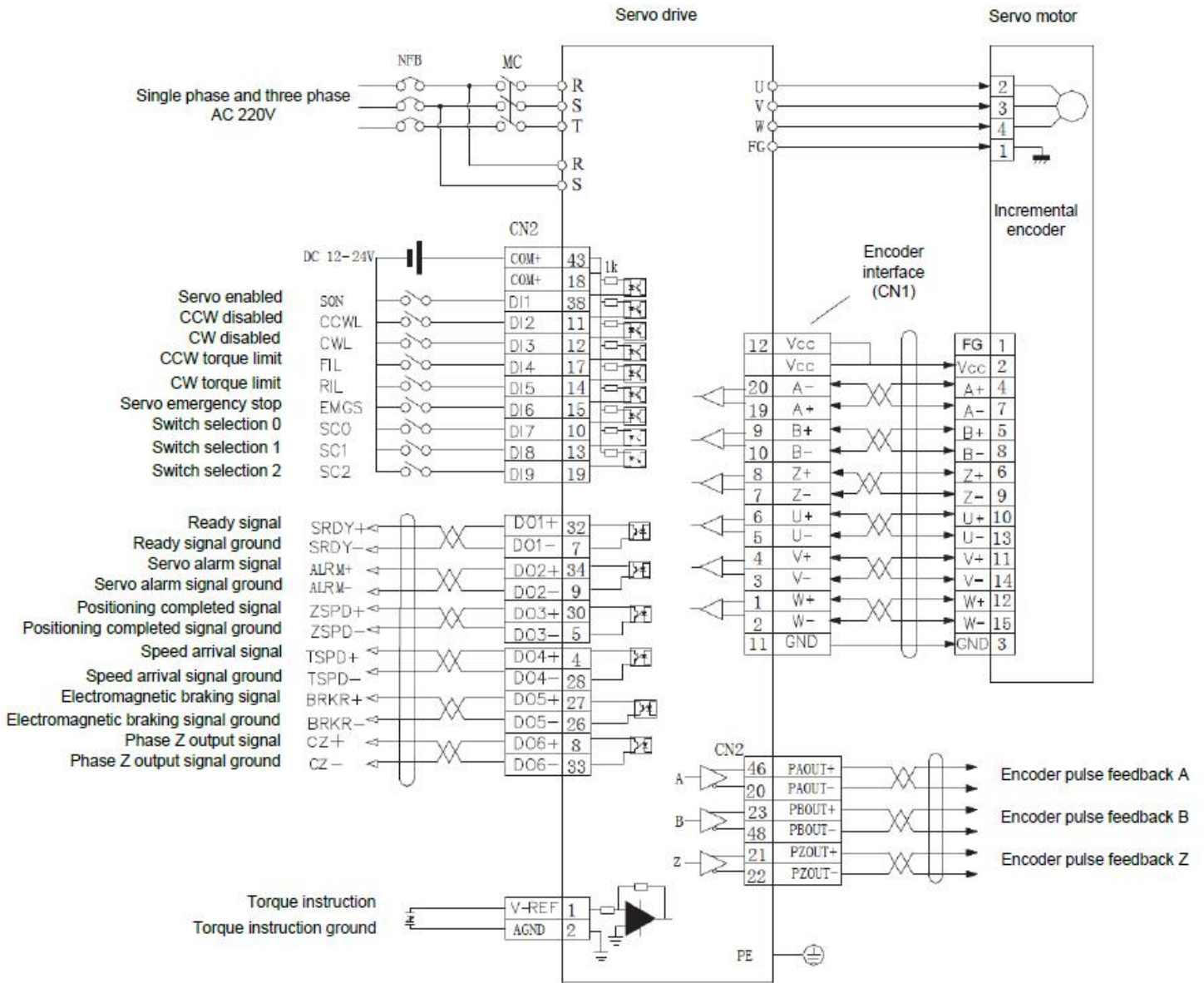

DSL200-P torque control (analog voltage mode) standard connecting

3.6.4.CN2 ports circuits

3.6.4.1.Speed analog instruction input signals

V-REF+ (CN2-3) / AGND (CN2-2) is the speed analog instruction input port. The Max. received voltage signal is 10VDC. Its port input impedance is 20KΩ.

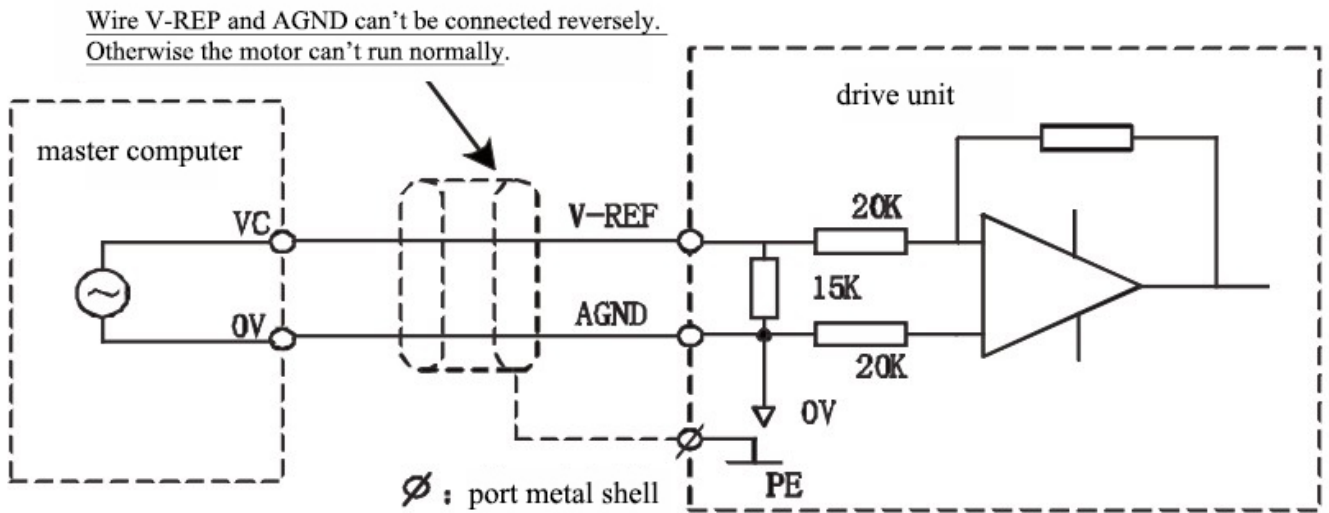
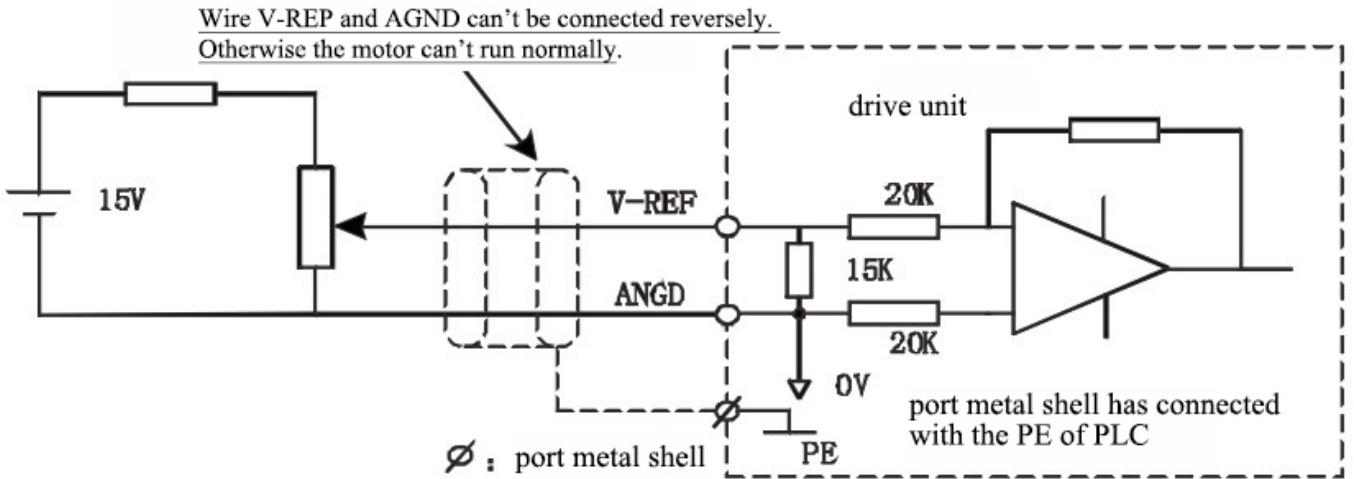

3.6.4.2. Torque analog instruction input signals

T-REF+ (CN2-1) / AGND (CN2-2) is the torque analog instruction input port. The Max. received voltage signal is 10VDC. Its port input impedance is 20KΩ.

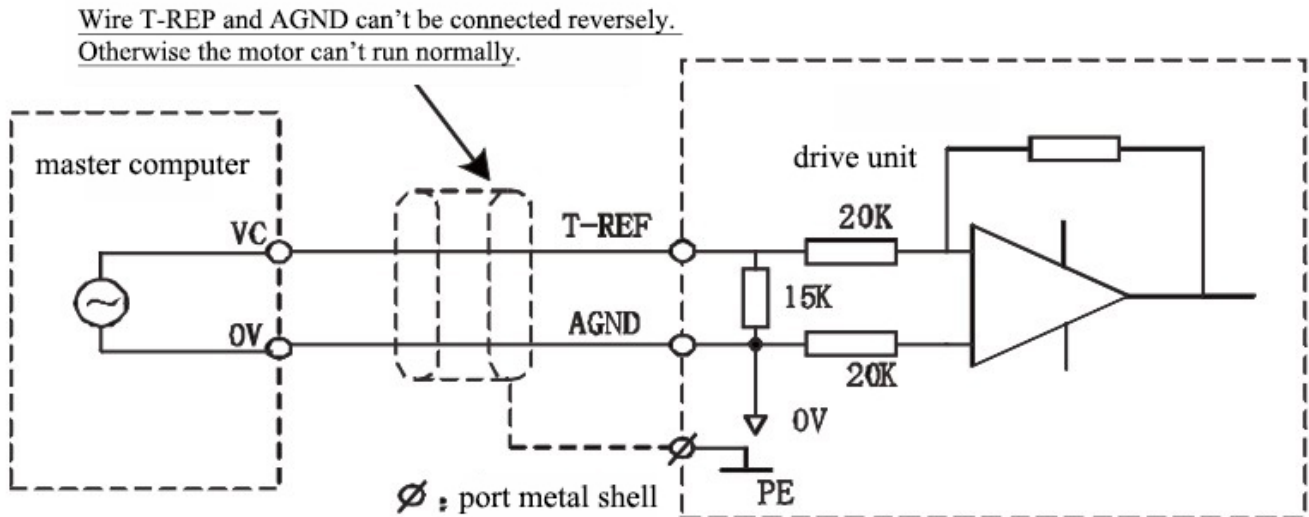
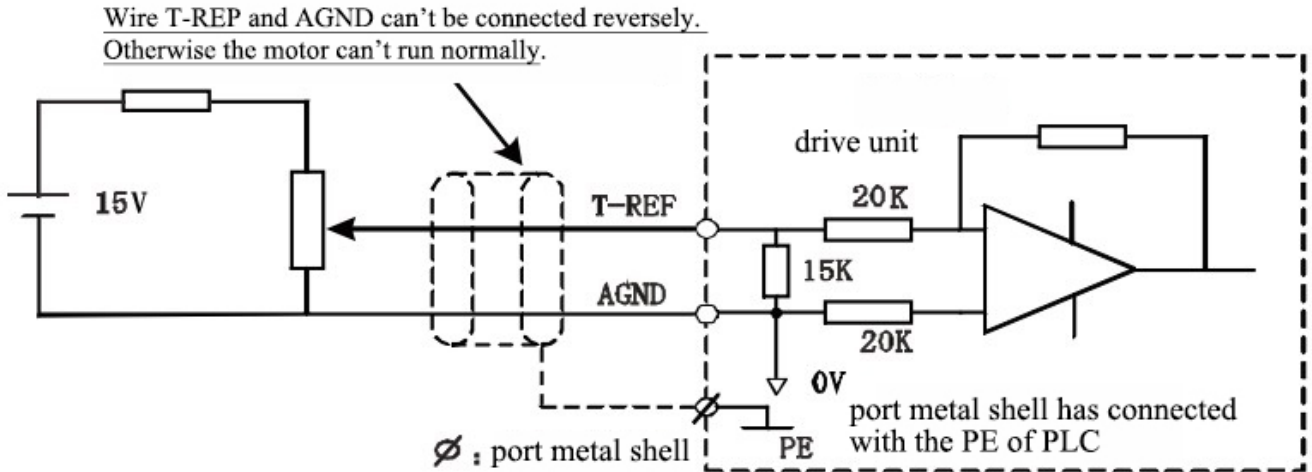

Notes: double cross-twisted wires are recommended for signal cable, although shielded cables are recommended, however it isn't always suitable.

3.6.4.3. Position instruction input signals

Type	Signal symbol	CN2 Pin No.	Definition
input	PULS+	49	instruction pulse input signal
	PULS-	50	instruction pulse input signal ground
	SING+	25	instruction pulse direction input
	SING-	24	instruction pulse direction input ground

User can adopt difference drive connecting, also can use single- terminal drive connecting. Which are shown as below.

3.6.4.3.1.Difference drive connecting

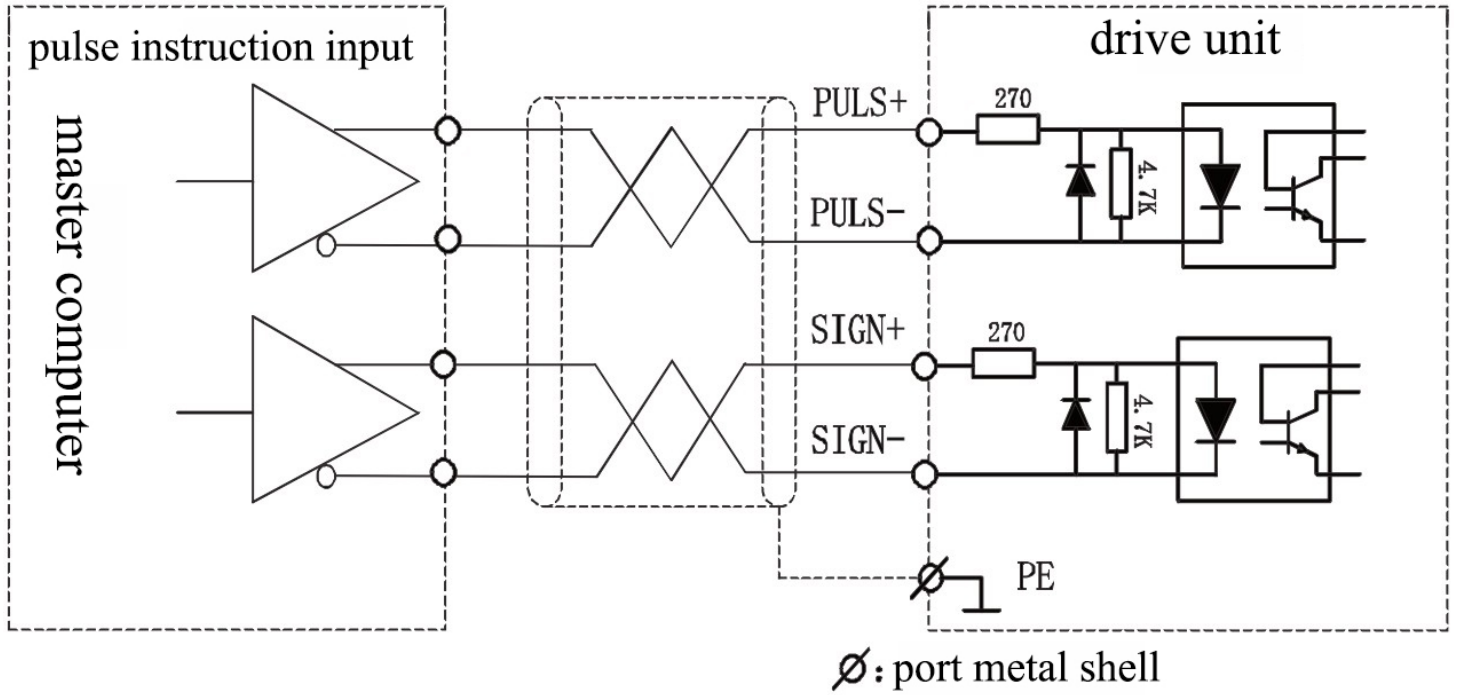

3.6.4.3.2.Terminal drive connecting

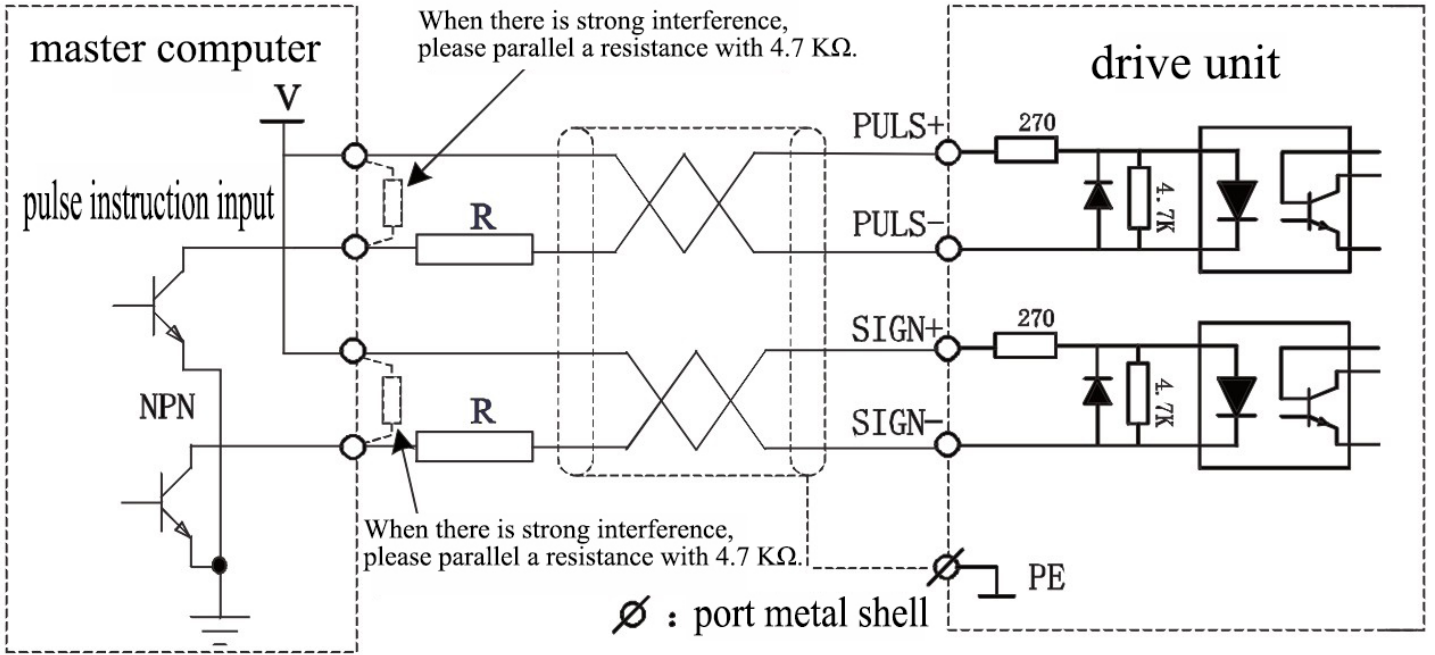

(a)NPN Single- terminal drive connecting

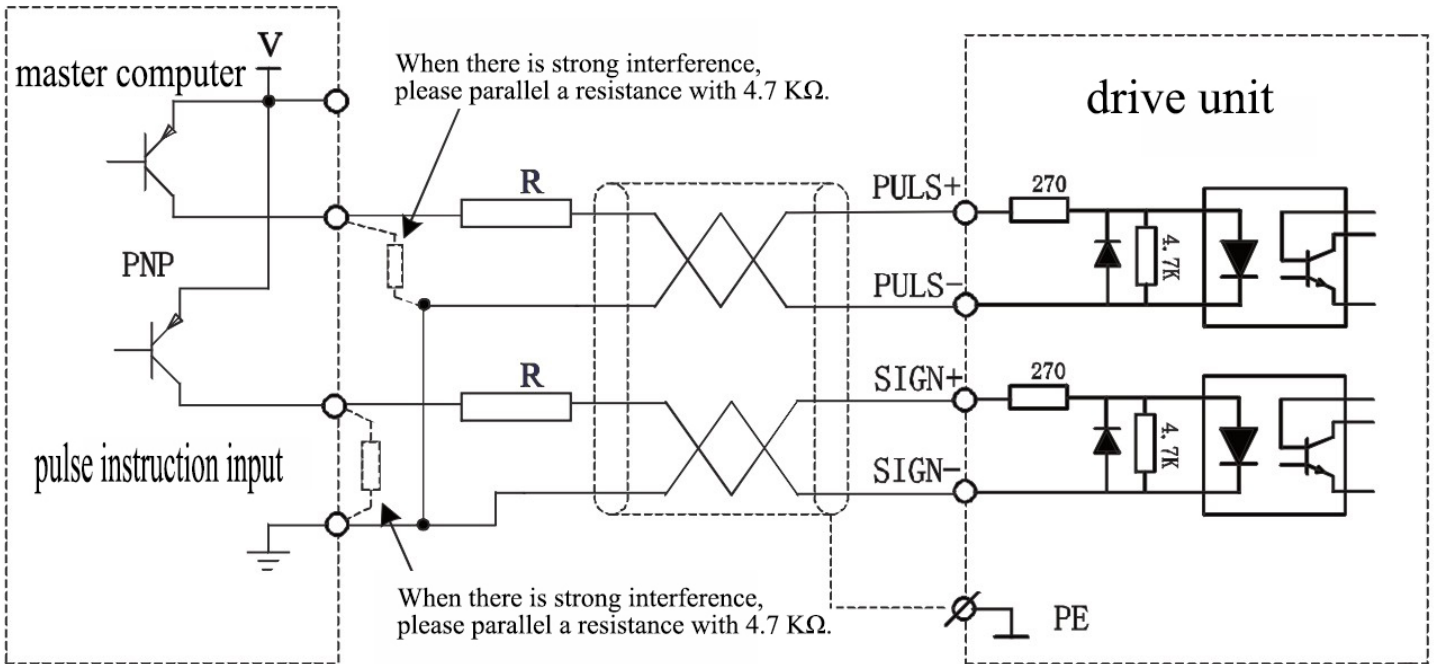

(b)PNP Single- terminal drive connecting

Notes:

- To correctly transmit pulse amount data, difference drive is recommended.
- Under difference drive, please adopt AM26LS31, MC3487 or similar as RS422 servo driver.

● Adopting single-terminal drive may decline the movement frequency. According to pulse amount input circuit, drive current 10~15mA, limit external power Max voltage condition, ascertain resistance value. experienced data: VCC=24V; R=1.3~2k=12V; R=510~820 Ω ; VCC=5V; R=82-120 Ω .

● When adopting single-terminal drive, user provides power supply. However, if reversely connect power supply polarity, servo drivers unit probably be damaged.

3.6.4.Pulse input mode selection

There are 8 receivable position instruction input modes which are set by P1-02 as shown in the following table, the arrows indicate counting edge.

pulse instruction mode	CCW	CW	parameters setting value
pulse direction			P1-02=0, 1, 2, 3 instruction pulse + direction
CCW pulse CW pulse			P1-02=4, 5 CCW pulse + CW pulse
phase A pulse phase B pulse			P1-02=6, 7 phase A,B pulse instruction

3.6.5.Control signals sequence diagram

3.6.5.1. Sequence diagram of pulse + symbol input interface (1MHz Max pulse frequency)

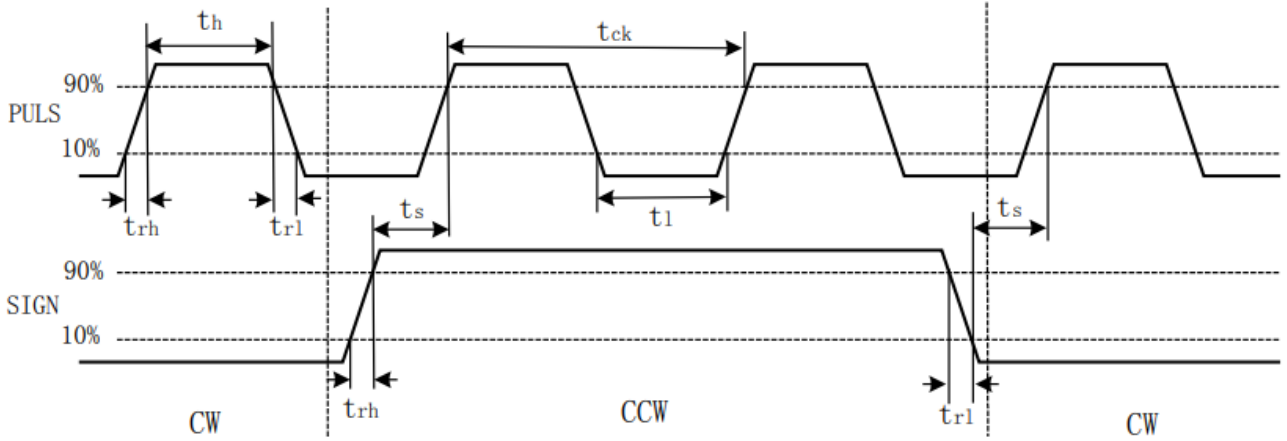

3.6.5.2. Sequence diagram of CCW/CW pulse input interface (1MHz Max pulse frequency)

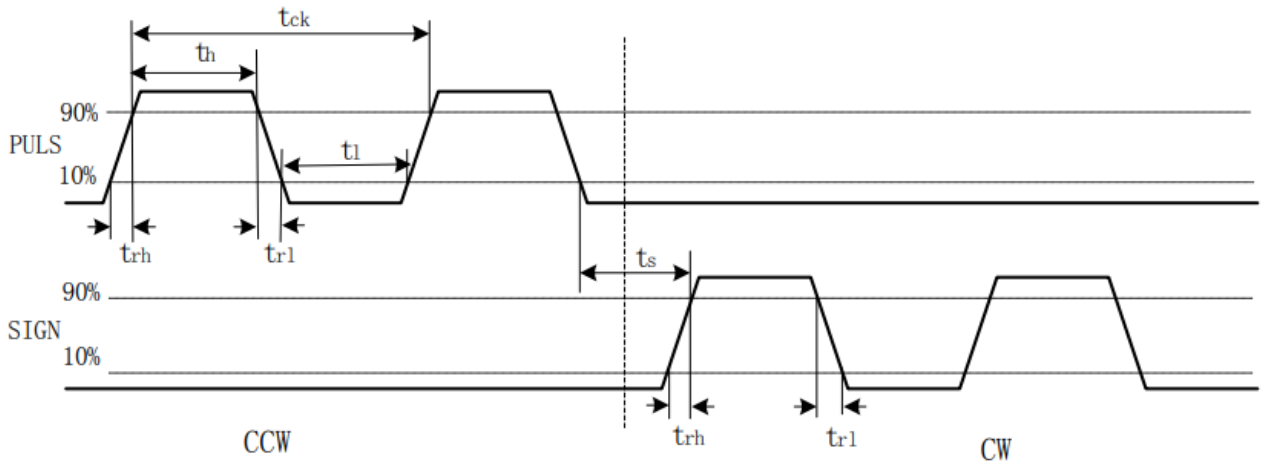

3.6.5.3. Sequence diagram of A/B phase instruction pulse input interface (1MHz Max pulse frequency)

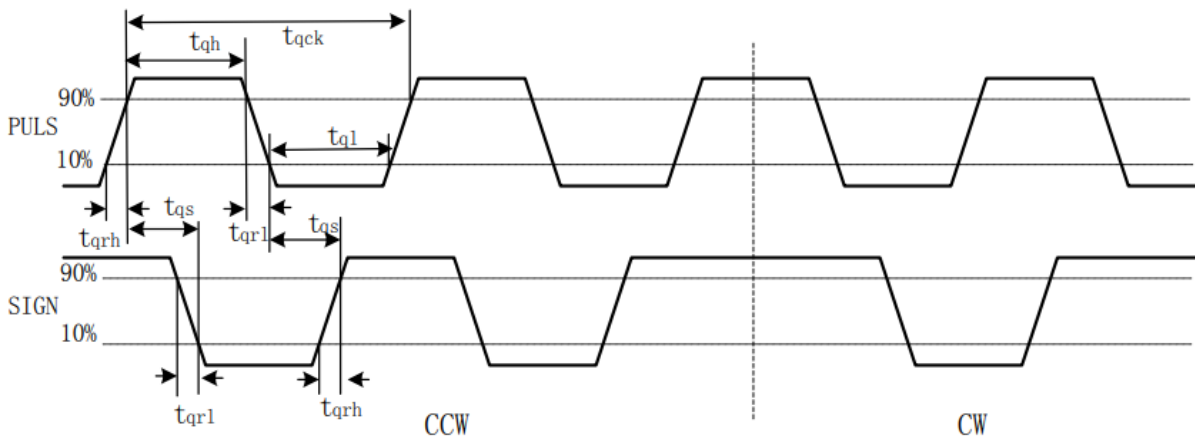

3.6.5.4. Sequence parameters table of pulse input

Parameters	t_{ck}	t_h	t_l	t_{rh}	t_{rl}	t_s	t_{qck}	t_{qh}	t_{ql}	t_{qrh}	t_{qrl}	t_{qs}
Difference drive input (μs)	>1	>0.3	>0.3	<0.2	<0.2	>2	>1	>0.3	>0.3	<0.2	<0.2	>0.2
Single-terminal drive input (μs)	>5	>2.5	>2.5	<0.3	<0.3	>2.5	>10	>5	>5	<0.3	<0.3	>2.5

Notes: When frequency more than 1MHz, overlength wires weaken signals, degrade anti-interference, then lose position pulse instruction.

3.6.6.Switch amount input signals

There hasn't 24V power supply output for servo unit, when the switch amount signals input, there need an extra external power supply with 24V. Specifications are DC15V~24V, >100mA. It is recommended to share the same power supply with output circuit. COM+(CN2-43) indicates the positive pole of the external power supply.

Two common connecting examples are below. INX indicates input point:(SON, CWL, CCWL, FIL, RIL, SPD2, SPD1, SPD0)

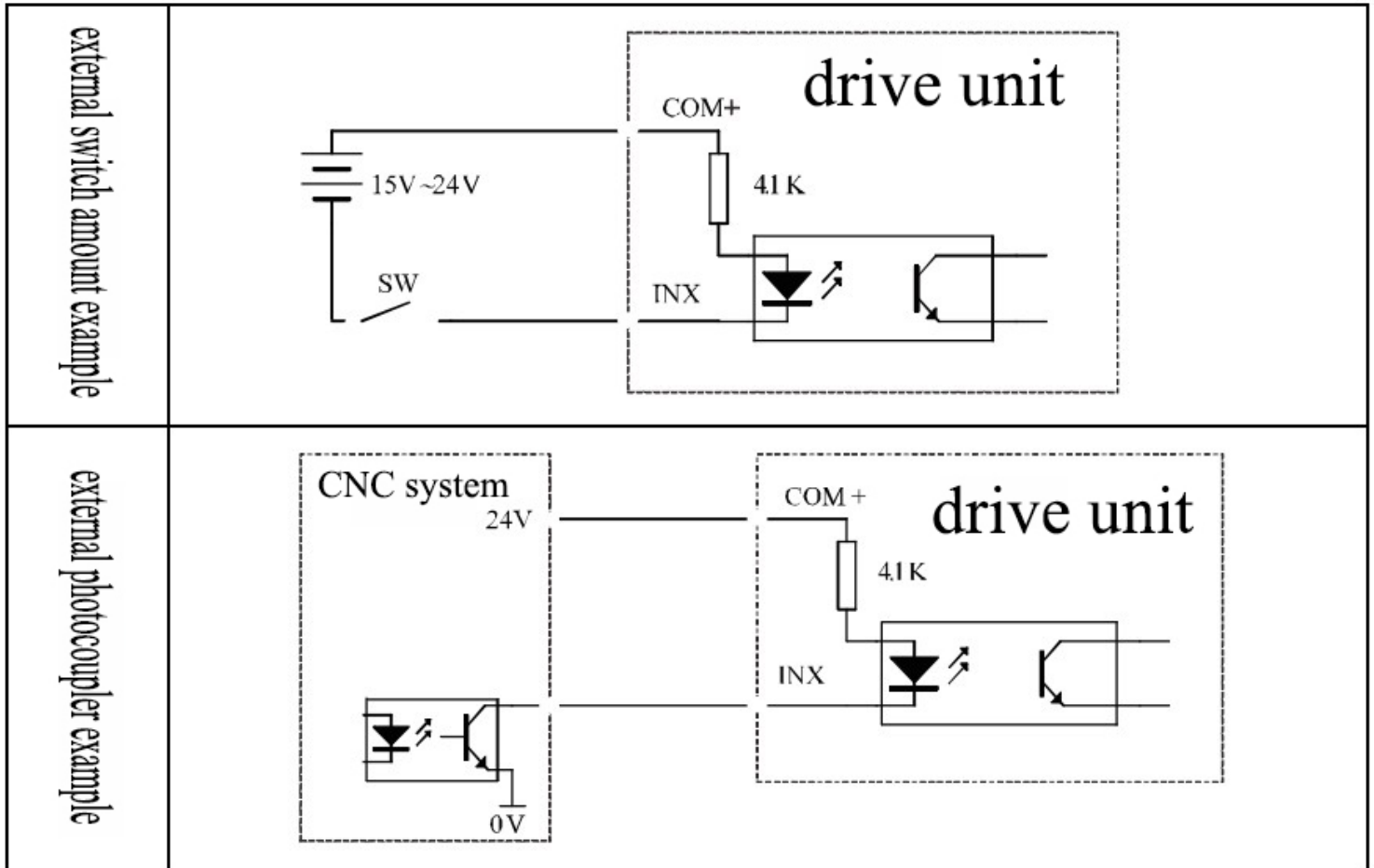

When SON (CN2-38) is “ON”, to start servo enable, looking up the monitor window Fn-20, “Rn-on” displays.

Parameters	implications	Unit	Default value	Suitable ways
P1-04	<p>Without external SON input signal, force to enable motor from inside the drive unit.</p> <p>P1-04=0: only when external input signal SON is "ON", can motor be enabled.</p> <p>P1-04=1: force to enable motor from inside the drive unit, so needn't external input signal SON.</p> <p>After P1-04 is set, press the "Enter" key for three seconds, "SAVE" appears, and it means that P1-04 will save the parameters values.</p>		0	P, S

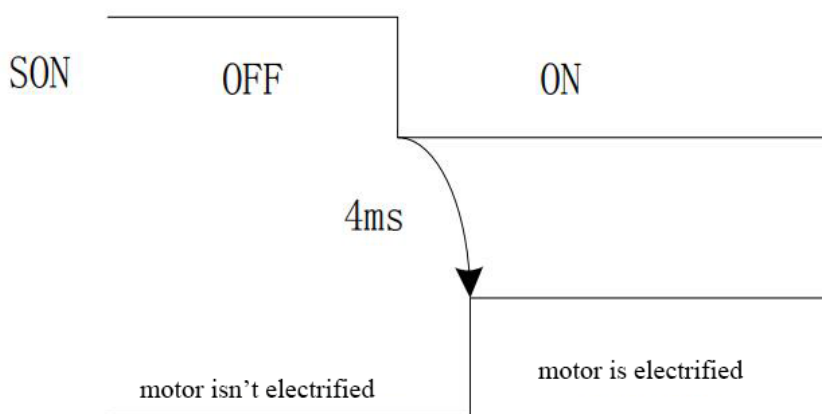

At this point, driver is normal, motor is electrified. If driver has failures, alarm codes will be displayed.

CCWL(CN2-11), CWL(CN2-12): drive forbidden signals, generally be used with stroke switch to avoid overrun.

input signal		running	
CCWL	CWL	CCW direction	CW direction
ON	ON	0	0
ON	OFF	0	forbidden
OFF	ON	forbidden	0
OFF	OFF	forbidden	forbidden

Notes:

- 0 means normal.
- When not using drive forbidden function, set P2-50 as 1. at this point, CCWL and CWL are in short connection.
- FIL(CN2-17) CCW torque limitation, when FIL is ON, as motor CCW running, Max torque is limited by P4-09.
- RIL(CN2-14) CW torque limitation, when RIL is ON, as motor CCW running, Max torque is limited by P4-10.

Notes:

- User provides power supply, DC12~24V, current ≥ 100mA.
- If reversely connecting current polarity, servo driver doesn't work.

3.6.7. Output signals

3.6.7.1. servo status signal output (double terminals integrated electrode):

◆ ALRM + (CN2-34), ALRM - (CN2-9) are the output signal when drive unit inspects abnormality. Output status is related with P1-48.

P1-48=2	drive unit alarms, ALM and DG connect.
P1-48=1002	drive unit alarms, ALM and DG shut off.

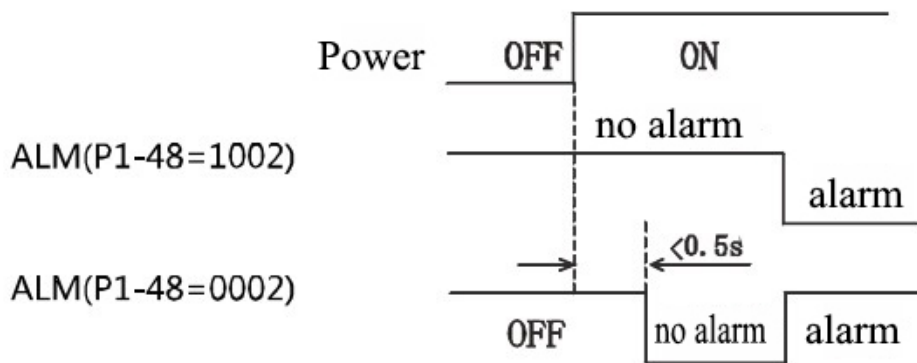

◎ SRDY+ (CN2-32), SRDY-(CN2-7) the signals of drive unit being ready for, when the motor is electrified and excited, when the signal is turned on.

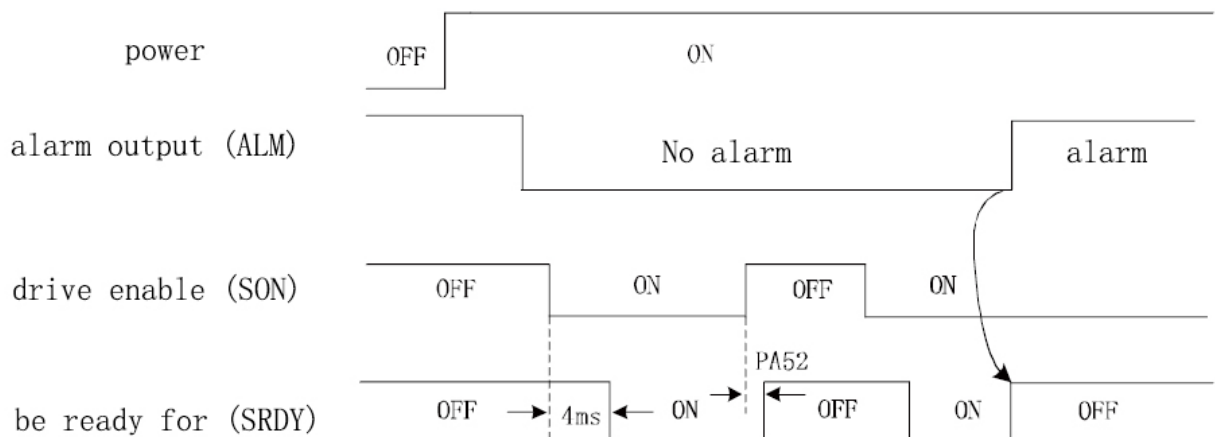

◆ ZSPD+ (CN2-30), ZSPD- (CN2-5) servo positioning completely output, When tracking deviation of motor position is less than P1-36, the signals are turned on.

◆ TSPD+(CN2-4), TSPD-(CN2-28) servo speed reach output, when the motor speed is more than or equal to P1-37, the signals are turned on.

◆ CZ+(CN2-8) / CZ- (CN2-33) position feedback output Z pulse signal, that is encoder, transferring signals.

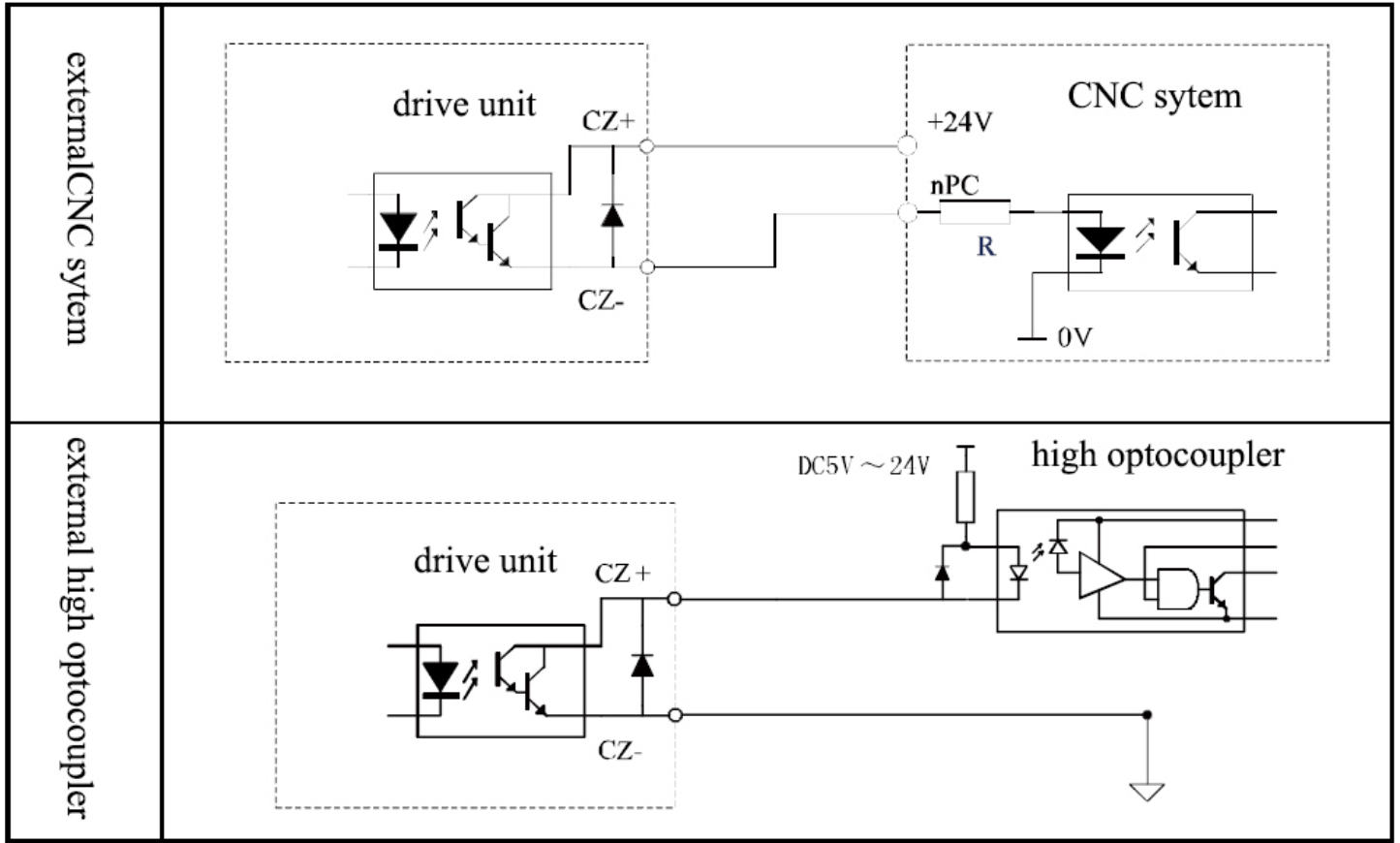

◆ BRKR+ (CN2-27) / BRKR- (CN2-26) brake release signal, external relay

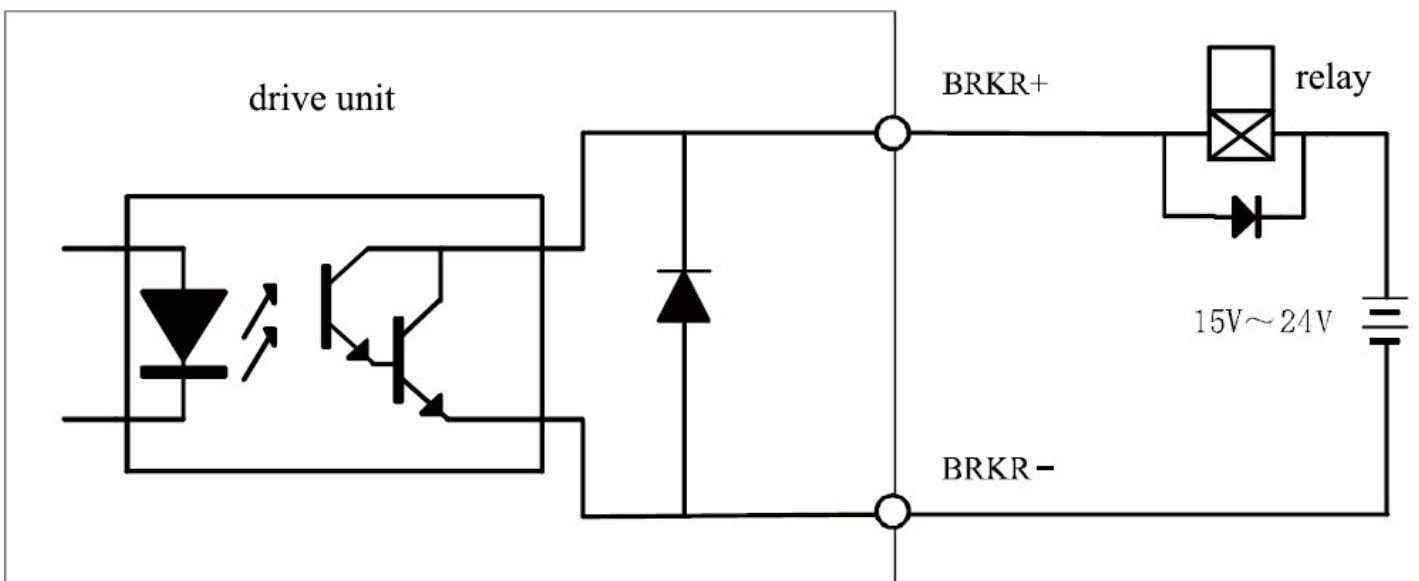

Notes:

- Output be the form of integrated electrode, 100mA Max load current, 25DCV Max external power supply voltage. If over the limited requirements or output connecting with the power supply directly, servo driver unit will be damaged.
- If the load is inductive, the freewheeling diode must be reversely paralleled at both ends of load. the wrong connecting of freewheeling diode will damage servo drive unit.
- Suggest to share the same power supply with input circuit.

3.6.7.2. servo feedback difference output

Position output signal PAOUT+/- PAOUT-, PBOUT+/- PBOUT-, PZOUT+/- PZOUT- adopt difference output. The position input signal from CN2 is the pulse signals of incremental encoder feedback such as the output signal form of Damagawa incremental encoder.

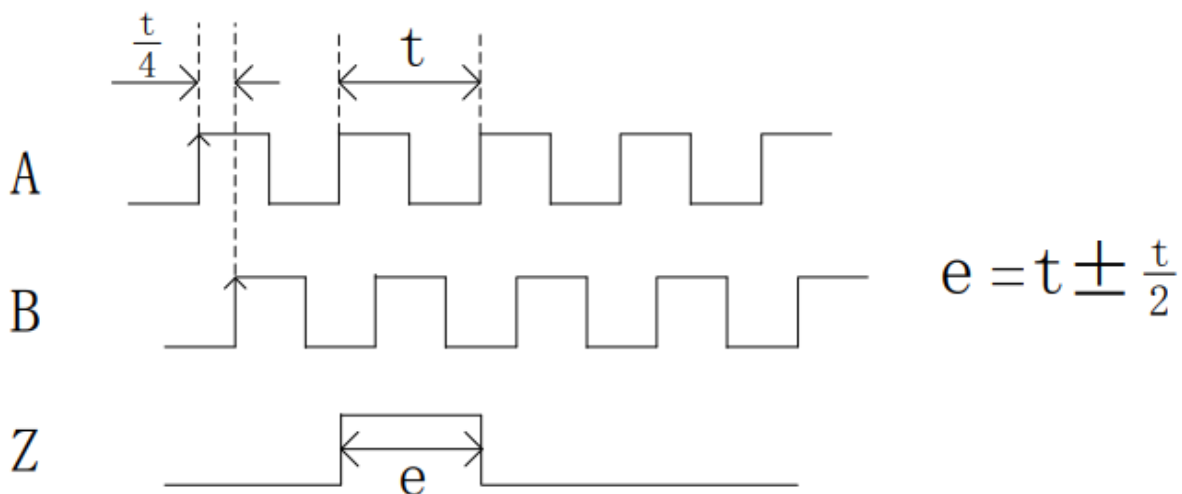

When P1-01=1,2, the position feedback output signal will output according to the wave form of position input signals. When P1-01=3,4, the position feedback output signals are reverse.

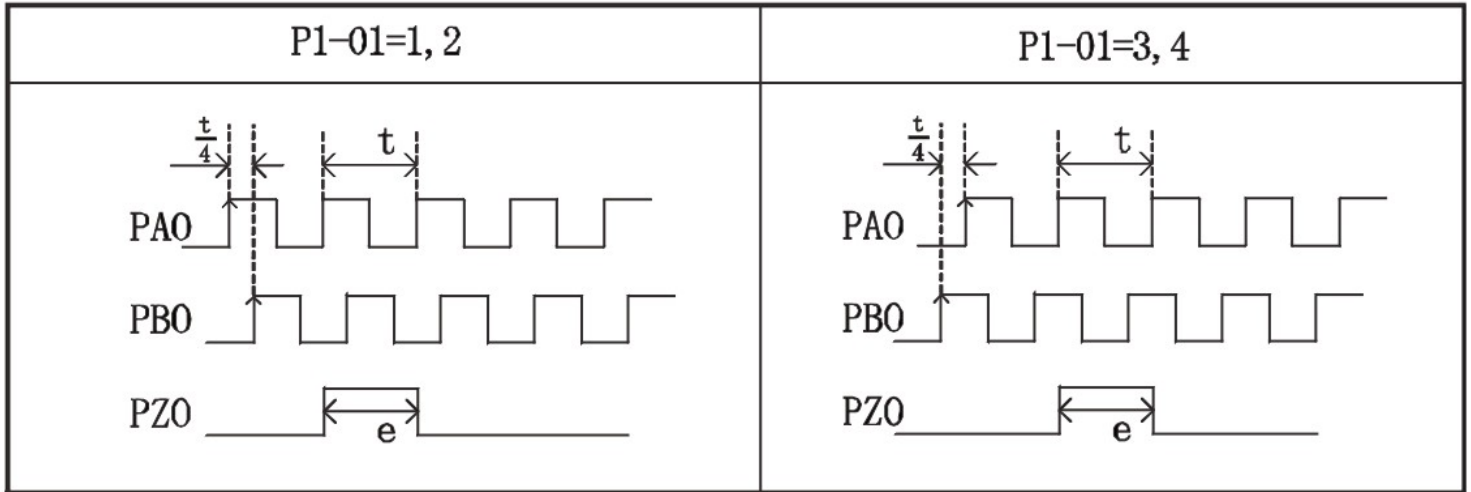

Wiring principle is as follow:

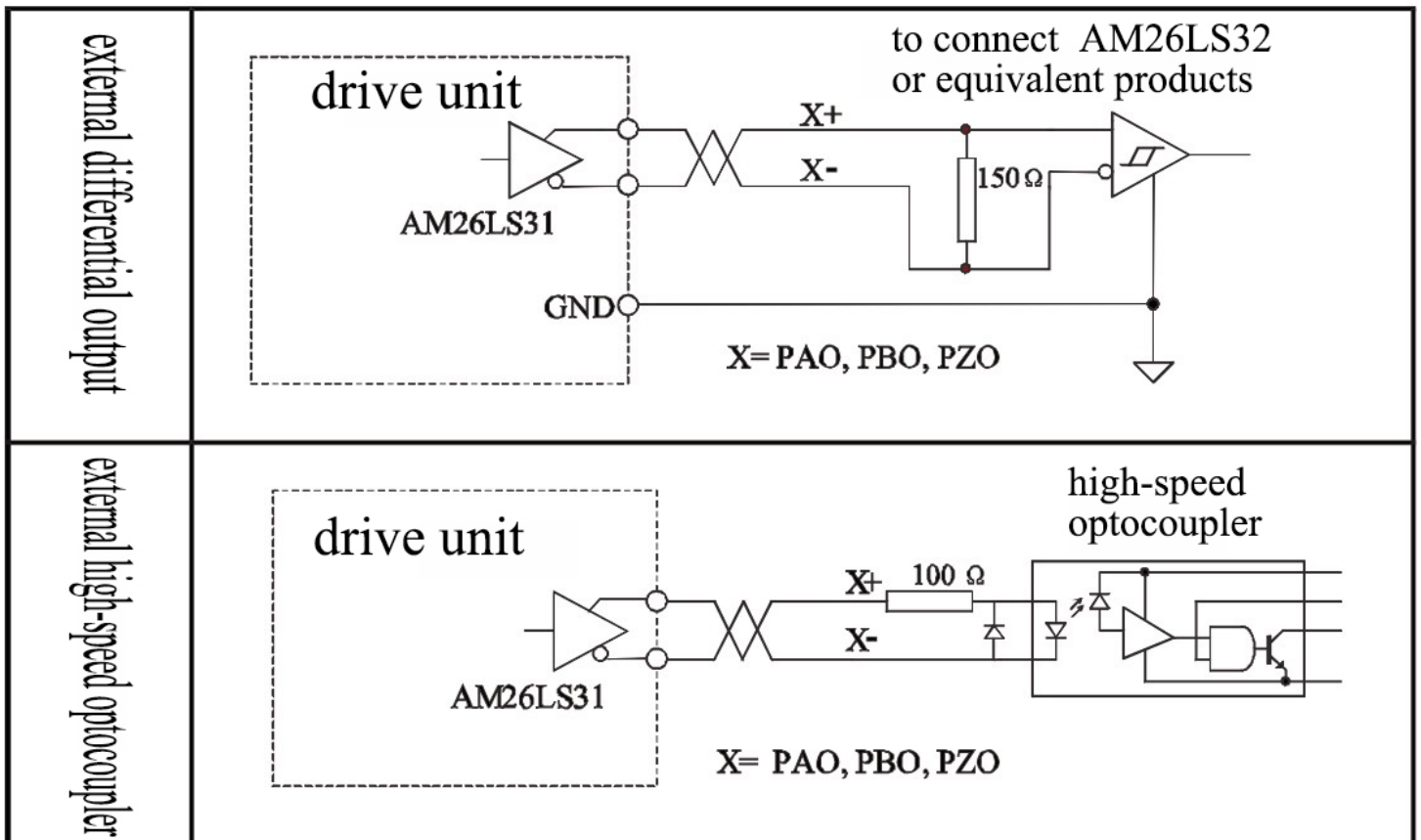

3.7. CN1 wiring and description

3.7. 1. CN1 wiring diagram (welding end)

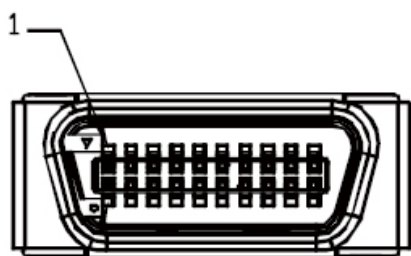

Front view of CN1 connecting terminals



Real view of CN1 connecting terminals

3.7. 2. CN1 port definition table

3.7. 2.1. CN1 ports definition list of 2500 lines incremental encoder

Pin No.	Pin Symbol	Definition	Remark
12	VCC	servo inner+5V	
11	GND	servo inner 0V	
19	A+	encoder input A+	double cross-twisted wire
20	A-	encoder input A-	
9	B+	encoder input B+	double cross-twisted wire
10	B-	encoder input B-	
8	Z+	encoder input Z+	double cross-twisted wire
7	Z-	encoder input Z-	
6	U+	encoder input U+	double cross-twisted wire
5	U-	encoder input U-	
4	V+	encoder input V+	double cross-twisted wire
3	V-	encoder input V-	
1	W+	encoder input W+	double cross-twisted wire
2	W-	encoder input W-	

3.7. 2.2. CN1 ports definition list of 17bits absolute encoder

Pin No.	Pin Symbol	Definition	Remark
12	VCC	+5V	
11	GND	0V	
10	SD+	485 communication data signal +	double cross-twisted wire
15	SD-	485 communication data signal -	

18	BAT+	3.6V cell positive polar	double cross-twisted wire
13	BAT-	3.6V cell negative polar	

3.7.3. CN1 pin description

All incremental encoder signal wires are difference drive connection, wiring principles shown as below.

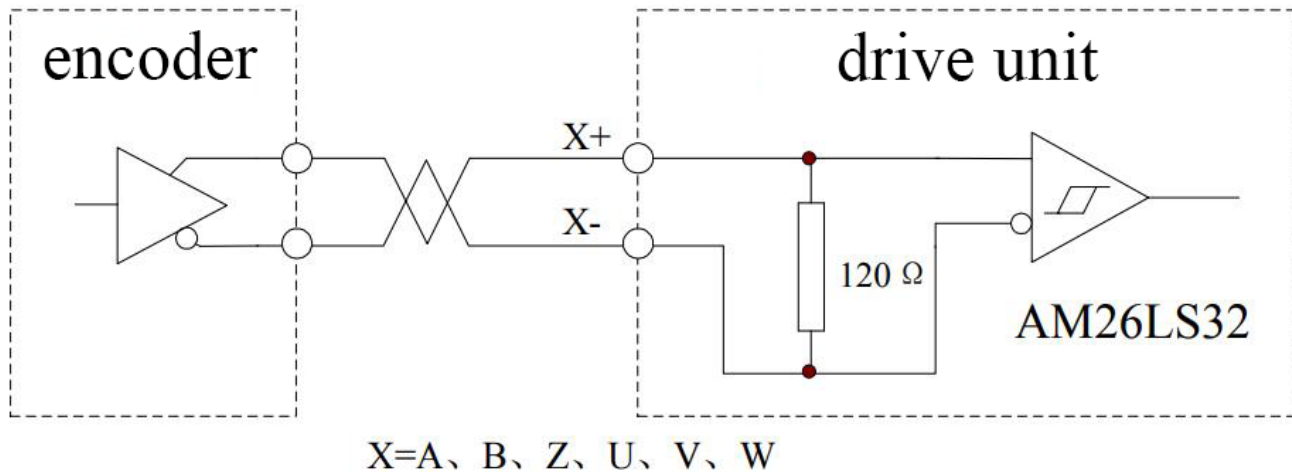

3.7.4. Function description of encoder signal input/output terminals CN1

terminal No.	signal name	terminals marks		function
		mark	I/O	
CN1-12	power supply output+	+5V	VCC	servo motor incremental encoder using +5V power, the wire should be long as possible, to use multiple cores in parallel
CN1-11	power supply output-	0V	GND	
CN1-19	encoder A+ input	A+	difference input	connecting with servo motor incremental encoder A+
CN1-20	encoder A- input	A-		connecting with servo motor incremental encoder A-
CN1-9	encoder B+ input	B+		connecting with servo motor incremental encoder B+
CN1-10	encoder B- input	B-		connecting with servo motor incremental encoder B-
CN1-8	encoder Z+ input	Z+		connecting with servo motor incremental encoder Z+
CN1-7	encoder Z- input	Z-		connecting with servo motor incremental encoder Z-
CN1-6	encoder U+ input	U+		connecting with servo motor incremental encoder U+
CN1-5	encoder U- input	U-		connecting with servo motor incremental encoder U-
CN1-4	encoder V+ input	V+		connecting with servo motor incremental encoder V+
CN1-3	encoder V- input	V-		connecting with servo motor incremental encoder V-
CN1-1	encoder W+ input	W+		connecting with servo motor incremental encoder W+
CN1-20	encoder W- input	W-		connecting with servo motor incremental encoder W-

Notes:

- The length of servo motor power supply wire and motor encoder feedback signal wire should be within 20m, and the distance between them should be more than 30cm. Both wires can't use the same tube or can't be bound up.
- Signal wire should be adopt the cross-twisted shielded cable, section area is $0.15\text{mm}^2\sim 0.20\text{mm}^2$, shielded layer should connect PE.

3.8. Connecting and description of communication terminals (CN3, CN4)**3.8.1. CN3, CN4 port definition table**

CN3(Crystal head plane end from left to right)			CN4(Crystal head plane end from left to right)		
Pin No.	Pin Symbol	Definition	Pin No.	Pin Symbol	Definition
8	RXD	RS232 data receiving	8	RXD	RS232 data receiving
6	TXD	RS232 data sending	6	TXD	RS232 data sending
4	RS-485-	RS485 digital signal-	4	RS-485-	RS485 digital signal-
2	RS-485+	RS485 digital signal+	2	RS-485+	RS485 digital signal+
1	GND	servo inner digital ground	1	GND	servo inner digital ground

3.8.1. Communications description

Baud rate:38400Bps (default)

Data length: 8 bits

Start bit:1 bit

Stop bit:1 bit

Check bit: none

Notes: When one PLC is for several drivers communication, please correctly set the station Number of the servo slave station.

Chapter 4 Display and Operation

4.1. Panel Operation

4.1.1. Panel appearance

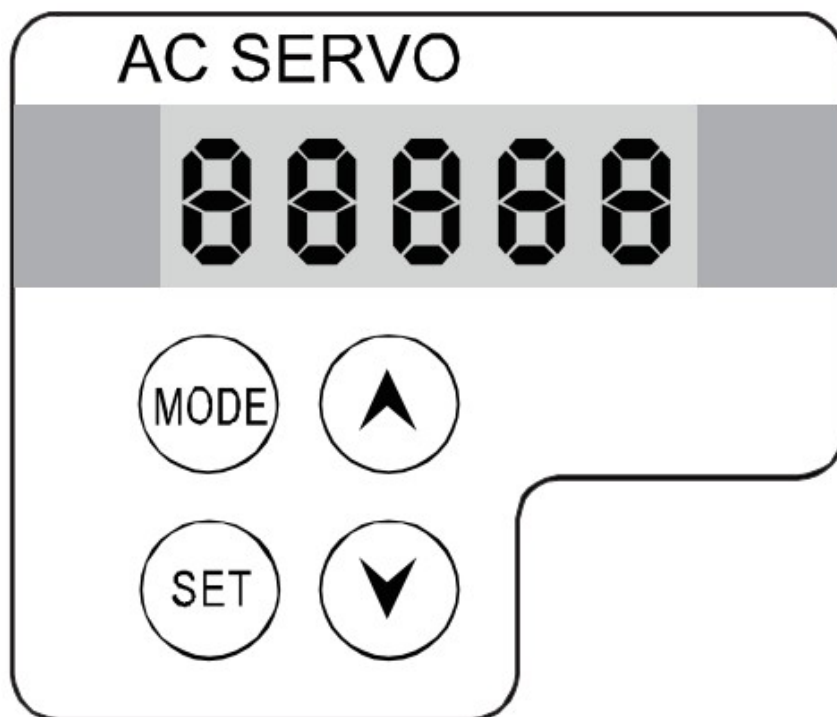

4.1.2. Panel function key

Drive unit panel is made up 5 LED digital tube display and 4 press keys (▲▼SET MODE), which shows each status and parameters setting of unit etc. The functions of press key is as follow.

- ▲: serial number, figure increasing, or options forward.
- ▼: serial number, figure decreasing, or options step backward.
- MODE: return to the previous operation, or cancel it.
- SET: go to the next step, or enter confirmation.

Notes: when keep to press the key ▲、▼, operations are carried out repeatedly. The longer the keep press time is, the more rapid the repeat frequency is.

4.1.2.1. Menu shift

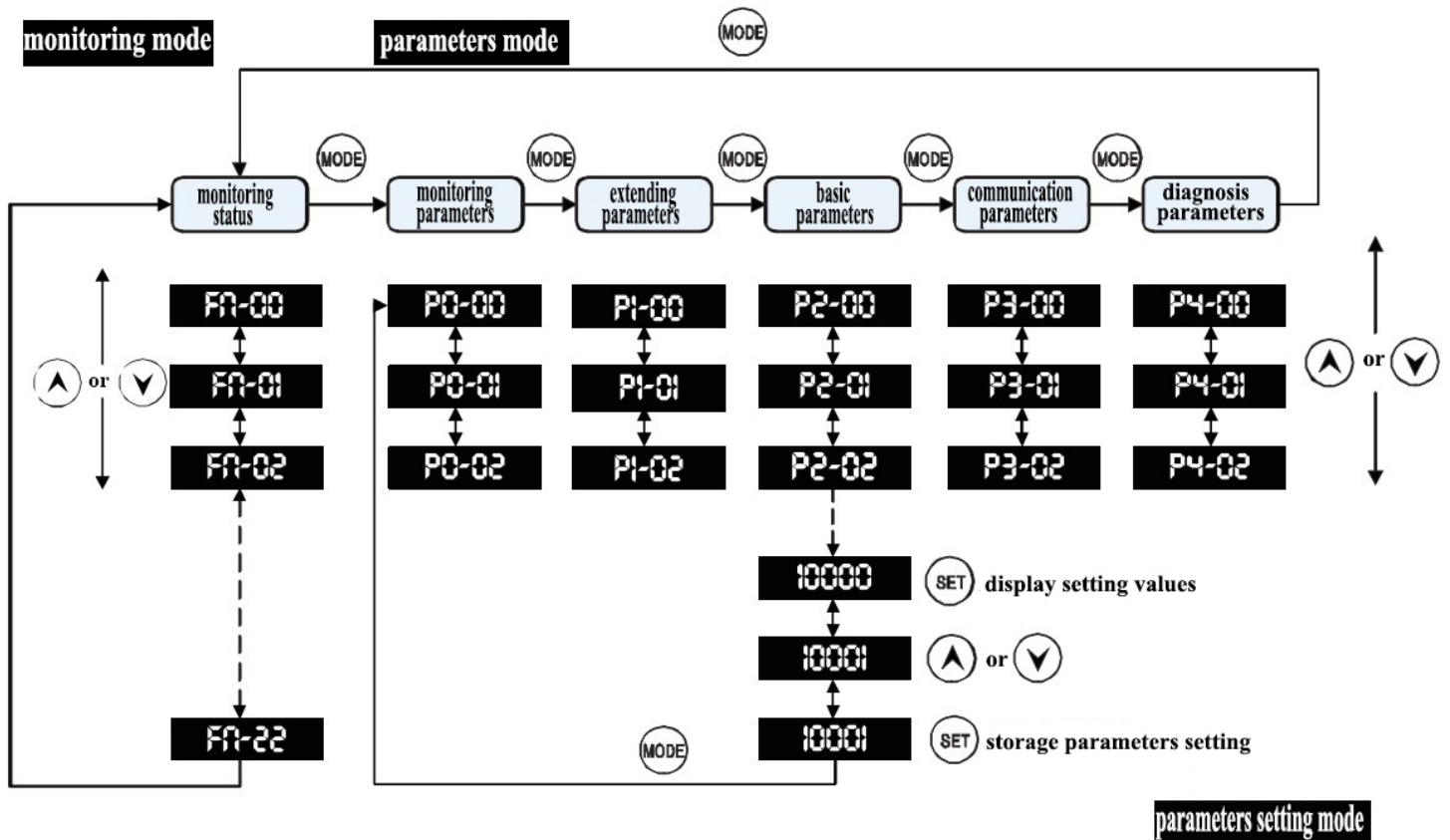

Mode selection operation block diagram





- ◆ When turn on the power of driver, the display device shows the monitoring symbol lasted for one second firstly, then starts the monitoring display mode.
- ◆ Under the monitoring mode, if press the key \uparrow or \downarrow , can switch the monitoring parameters, monitoring display symbol will show lasted for one second.
- ◆ Under the monitoring mode, if press the key MODE , can switch the monitoring mode and parameters mode freely. Under the parameters mode, press the key \uparrow or \downarrow , can alter the following-two-characters parameters number.
- ◆ Under the parameters mode, press the key SET , system immediately goes to setting mode, the display simultaneously shows the parameter and its setting value. In this case, can modify the parameters value by the key \uparrow or \downarrow , or press the key MODE to leave the setting motor, and return to parameters mode. When modify the parameters, a decimal dot appears under the lower right corner of the parameters value.
- ◆ After finishing the modification of setting value, press the key SET , can carry out the instruction of parameter storage and executive.
- ◆ After finishing the parameters setting, the decimal dot in the display vanishes, press the key MODE , can switch to other parameters group or monitoring mode.

4.2. Menu

4.2.1. Menu summary

Menu code	Submenu name	Function
Fn-00 ~ Fn-22	monitoring status	to show the status information of servo driver such as speed, current and so on.
P0-00 ~ P0-03	monitoring parameters	to show software and hardware version of servo driver, and factory parameter recovery.
P1-00 ~ P1-62	extending parameters	to set the corresponding parameters can extend some functions of servo driver.
P2-00 ~ P2-61	basic parameters	the common parameters setting of user, like PID proportional gain, integral coefficient etc.
P3-00 ~ P3-07	communications parameters	To realize the communications with the master computer, like RS-232, RJ-485.
P4-00 ~ P4-62	diagnosis parameters	to record alarm number, analog instruction function setting, single-shaft function timer.

4.2.2. Monitor states

In the layer 1 of menu, to press the key , can switch to the grade 1 menu of monitoring states. There have 23 kinds of display status from Fn-00~Fn-22. By the key  or , user can select the needed display mode, then press the key , can go to the grade 2 menu of monitoring states, can display the specific states.

grade 1 menu	function	grade 2 menu	content	communication address (decimal system)
Fn-01	lower than present position 4 bits (pulse)	P 5806	present position , 145806 pulse	4×1281
Fn-02	higher than present position 4 bits (×10000 pulse)	P.14		4×1282
Fn-03	lower than position instruction 4 bits (pulse)	C 5810	position instruction , 145810 pulse	4×1283
Fn-04	higher than position instruction 4 bits (×10000 pulse)	C.14		4×1284
Fn-05	lower than position deviation 4 bits (pulse)	E 4	position deviation , 4 pulse	4×1285
Fn-06	higher than position deviation 4 bits (×10000 pulse)	E. 0		4×1286

Fn-07	position instruction pulse frequency (KHz)	F 12.6	position instruction pulse frequency 12.6KHz	4×1287
Fn-08	motor speed (r/min)	R 1000	motor speed 1000r/min	4×1288
Fn-09	speed analog instruction input (V)	S 2.5	speed analog voltage 2.5V	4×1289
Fn-10	speed analog instruction input (rpm)	S. 750	speed analog instruction 750r/min	4×1290
Fn-11	torque analog instruction input (V)	T 2.5	torque analog voltage 2.5V	4×1291
Fn-12	torque analog instruction input (%)	T. 25	torque analog instruction 25%	4×1292
Fn-13	average current (A)	I 2.3	average current 2.3A	4×1293
Fn-14	peak current (A)	I. 3.5	peak current 3.5A	4×1294
Fn-15	motor feedback pulse amount (relative value)	A 3265	rotor absolute position value 3265	4×1295
Fn-16	motor feedback pulse amount (absolute value)	A. 0		4×1296
Fn-17	input states terminal	In 1111	input terminal	4×1297
Fn-18	output states terminal	Out 11	output terminal	4×1298
Fn-19	encoder value input signal	Cod --	encoder language	4×1299
Fn-20	servo running states	Rn On	in process	4×1300
Fn-21	alarm code	ALE 9	No.9 alarms	4×1301
Fn-22	external speed analog voltage input display	U 0.000	external input speed analog voltage 0.000V	4×1302
Fn-23	external torque analog voltage input display	U 0.000	external input torque analog voltage 0.000V	4×1303
Fn-24	servo alarm amount memorizing	AC 8	servo has given 8 alarms	4×1304

◆ Feedback position of motor encoder is consisted of Fn-02 (high 5 bit) + Fn-01 (low 5 bit). For instance:

$$P. \quad 18 \times 10000 + P45806 = 1845806 \text{ pulse}$$

likewise, position instruction pulse is also consisted of Fn-04(high 5 bit) + Fn-03 (low 5 bit), for example:

$$\boxed{C. \quad 18} \times 10000 + \boxed{C458 \quad 10} = 1845810 \text{ pulse}$$

The relationship between position feedback and position instruction pulse is shown as below.

$$\boxed{P.000000} \times 100000 + \boxed{P000000} = \frac{P1-06}{P1-10} (\boxed{C.000000} \times 100000 + \boxed{C000000})$$

similarly, position deviation is consisted of Fn-06 (high 5 bit) + Fn-05 (low 5 bit), for instance:

$$\boxed{E. \quad 0} \times 100000 + \boxed{E \quad 4} = 4 \text{ pulse}$$

◆ For $\boxed{r \quad 1000}$, r is the speed code of motor, 1000 means that motor is running at the speed of 1000r/min CCW . In $\boxed{- \quad 1000}$, -1000 means that motor is running at the speed of 1000r/min CW.

◆ Position instruction pulse frequency is the actual pulse frequency before the input electronic gears is amplified. Min unit is 0.1kHz, positive direction displays positive values, negative direction displays negative values.

◆ Calculation equation of motor current I is shown as the following.

$$I = \sqrt{\frac{2}{3}(I_U^2 + I_V^2 + I_W^2)}$$

◆ Absolute position of rotor in one round means that rotor is in the place relative to stator in a circle. One round is a cycle. Cycle range of incremental encoder in one round is 0~10000. Cycle range of 17 bits absolute encoder in one round is 0~131072.

◆ Running status

"rn-OFF": main circuit isn't electrified, servo system doesn't work.

"rn-CH": main circuit is electrified, servo system doesn't work (servo doesn't enable or there are alarms).

"rn-ON": main circuit is electrified, servo system works normally..

◆ Alarms display "ALE--" means that it is normal, no alarms

◆ Input terminals are shown as the below.

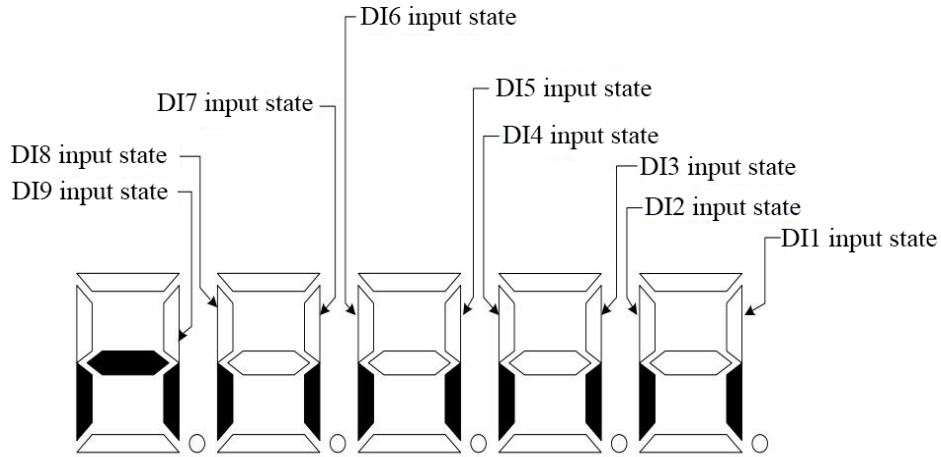

◆ Output terminals are shown as the below.

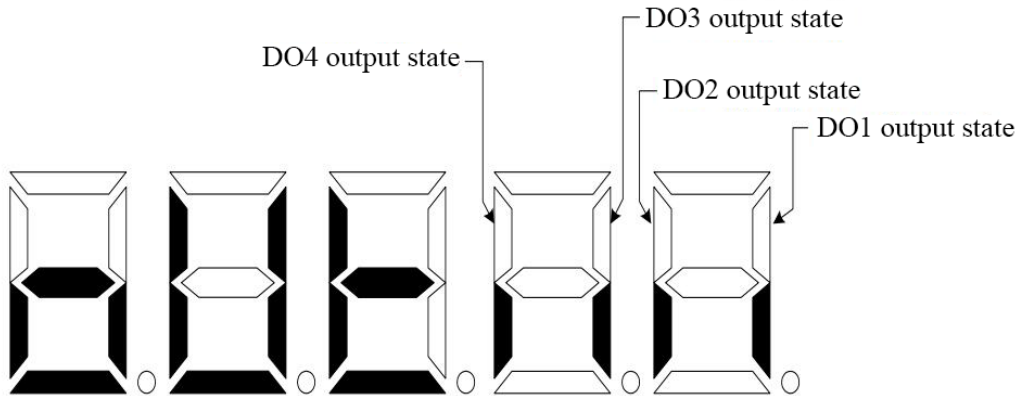

4.2.3. Parameter setting

4.2.3.1. Recovering default values

To recover default values: when leave the factory, for each servo driver, each type motor has a corresponding code, to set P1-05 parameters values according to motor code. After setting P0-02 up to 1, the present values freely recover the factory default values.

Related parameters	Name	Unit	Parameter range	Default values	Suitable ways
P1-05	motor type code		0~100	0	Pt, S
P0-02	executive operation code		0~2	0	Pt, S

4.2.3.2. Servo motor type code

Servo motor type code is as follow:

type code	matched motor type	motor flange	rated power	rated current	rated torque	rated speed	number of pole-pairs
10	40ST-M00330	40mm	100W	0.9A	0.319N.m	3000rpm	4
11	60ST-M00630	60mm	200W	1.5A	0.637N.m	3000rpm	4
2	60ST-M01330	60mm	400W	2.8A	1.27N.m	3000rpm	4
13	60ST-M01930	60mm	600W	3.5A	1.91N.m	3000rpm	4
21	80ST-M01330	80mm	400W	2.0A	1.27N.m	3000rpm	4
22	80ST-M02430	80mm	750W	3.0A	2.4N.m	3000rpm	4
23	80ST-M03530	80mm	730W	3.0A	3.5N.m	2000rpm	4
24	80ST-M04025	80mm	1KW	4.4A	4.0N.m	2500rpm	4
31	90ST-M02430	90mm	750W	3.0A	2.4N.m	3000rpm	4
32	90ST-M03520	90mm	750W	3.0A	3.5N.m	2000rpm	4
33	90ST-M04025	90mm	1KW	4.0A	4.0N.m	2500rpm	4
41	110ST-M02030	110mm	600W	2.5A	2.0N.m	3000rpm	4
42	110ST-M04020	110mm	800W	3.5A	4.0N.m	2000rpm	4
43	110ST-M04030	110mm	1.2KW	5.0A	4.0N.m	3000rpm	4
44	110ST-M05030	110mm	1.5KW	6.0A	5.0N.m	3000rpm	4
45	110ST-M06020	110mm	1.2KW	4.5A	6.0N.m	2000rpm	4
46	110ST-M06030	110mm	1.8KW	6.0A	6.0N.m	3000rpm	4
51	130ST-M04025	130mm	1.0KW	4.0A	4.0N.m	2500rpm	4
52	130ST-M05025	130mm	1.3KW	5.0A	5.0N.m	2500rpm	4
53	130ST-M06025	130mm	1.5KW	6.0A	6.0N.m	2500rpm	4
54	130ST-M07725	130mm	2.0KW	7.5A	7.7N.m	2500rpm	4
55	130ST-M10010	130mm	1.0KW	4.5A	10.0N.m	1000rpm	4
56	130ST-M10015	130mm	1.5KW	6.0A	10.0N.m	1500rpm	4
57	130ST-M10025	130mm	2.6KW	10.0A	10.0N.m	2500rpm	4
58	130ST-M15015	130mm	2.3KW	9.5A	15.0N.m	1500rpm	4
59	130ST-M15025	130mm	3.8KW	13.5A	15.0N.m	2500rpm	4
61	180ST-M17215	180mm	2.7KW	10.5A	17.2N.m	1500rpm	4
62	180ST-M19015	180mm	3.0KW	12.0A	19N.m	1500rpm	4
63	180ST-M21520	180mm	4.5KW	16.0A	21.5N.m	2000rpm	4
64	180ST-M27010	180mm	2.9KW	12.0A	27.0N.m	1000rpm	4
65	180ST-M27015	180mm	4.3KW	16.0A	27.0N.m	1500rpm	4
66	180ST-M35010	180mm	3.7KW	16.0A	35.0N.m	1000rpm	4
67	180ST-M35015	180mm	5.5KW	19.0A	35.0N.m	1500rpm	4
68	180ST-M78015	180mm	7.5KW	32.0A	48.0N.m	1500rpm	4
69	180ST-M23825	180mm	5.5KW	19.7A	23.8N.m	2000rpm	4

◆ The numbers of pole-pairs of servo motor in the above table all are 4, when recover default parameters, please correctly set P1-05 value according to above table, then carry out the default parameters to recover the operation. To want to recover other numbers of pole-pairs of servo motor default parameters value, please contact the manufacture.

◆ When set P0-02 up to 1, servo driver freely recovers the default parameters according to P1-05 value. Other setting values haven't been defined up to now.

4.2.3.3. Modifying parameters

◆ In layer 1, to select "Px-xx", press key **SET** to enter parameters setting mode. By key **▲** or **▼**, to select parameters number, press key **SET**, then display parameter value, key **▲** or **▼** can modify parameter value.

◆ Press key **▲** or **▼** each time, parameter value increases or reduces 1. If keep pressing **▲** or **▼**, parameter can be increased or reduced continuously.

◆ When parameters are modified, the decimal point light at the rightmost LED digital tube is on, press key **SET**, then ensure the modified values are effective, at this point, the decimal point light at the rightmost LED digital tube is off.

◆ The modified values will be transmitted to the controller immediately, then can keep to modify parameters by key **▲** or **▼**, after modification finished, press key **MODE** to return parameter selection states.

◆ If not satisfy with the modified values, don't press key **SET** to confirm, can press key **MODE** to cancel. At the meantime, parameters recovery the former values, and return parameter selection states.

4.2.3.4. Parameters setting operation diagram

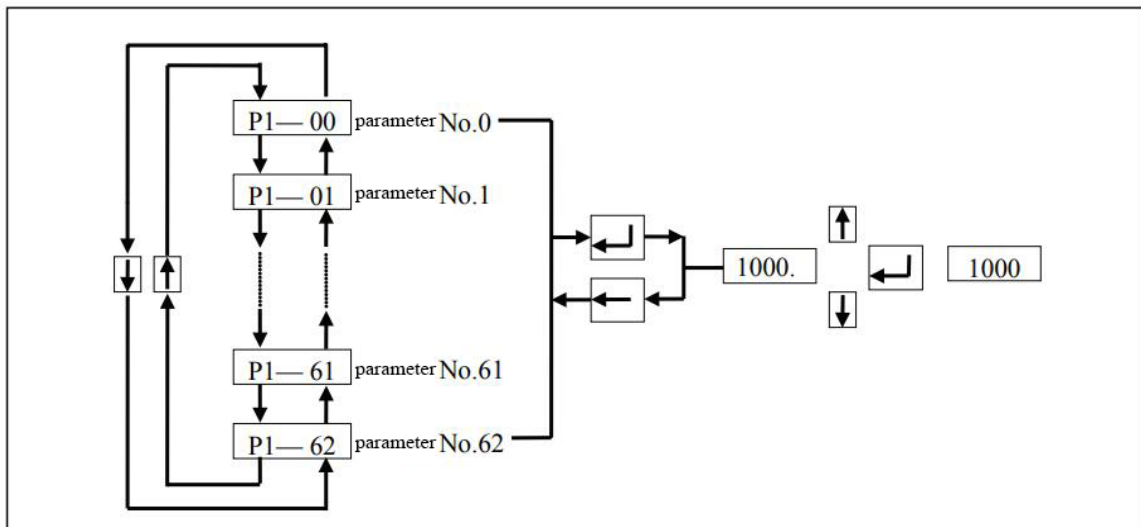

Notes:

If the modified parameters haven't been done writing operation, when the power supply is off, no save for the parameters, modification be ineffective.

Chapter 5 Parameters and Function

Notices:

- The people who sets the parameters must understand the real meanings of parameters. The incorrect set maybe damage the device or hurt people.
- Before setting parameters, no load for servo motor is suggested. If the motor doesn't work normally due to the parameters modification, can carry out the parameters default values to recover.

5.1 Parameter Definition

There are following five groups of parameters definition. The first character followed parameter start code P is the group character. The followed two characters are parameters characters. The communications address is made up of group character and the parameters characters with 16 bits value. Parameters group definition is as follow.

group 0: monitoring parameters	(such as P0-xx)
group 1: extending parameters	(such as P1-xx)
group 2: basic parameters	(such as P2-xx)
group 3: function parameters	(such as P3-xx)
group 4: spreading parameters	(such as P4-xx)
group 5: operation monitoring	(such as Fn-xx)

5.1.1. Control mode description

All: all modes

Pt: position control mode (position instruction is inputted by CN2)

Pr: position control mode (position and speed instructions are given by servo driver internal parameters)

S: speed control mode (speed instructions are given by external analogue voltage or internal parameters)

T: torque mode 1 (external analogue voltage or internal register input)

Ts: torque mode 2 (torque/ speed external input)

Pt_S: Pt and S can be switched by DI signal

Pr_S: Pr and S can be switched by DI signal

Pt_T: Pt and T can be switched by DI signal

Pr_T: Pr and T can be switched by DI signal

Pt_Pr: Pt and Pr can be switched by DI signal

S_ST: S and T can be switched by DI signal

Jrt: motor jogging run mode (internal register input)

Jrr: motor jogging run mode (external instruction input)

Sr: motor trial run mode

JOG: motor jogging mode

OL: motor test mode

OP: motor open loop mode



CO: encoder debugging mode

5.1.2. Monitor mode description

Control mode group	Subgroup	P1-00 setting value	Description
P (position control)	Pt	0	external position control
	Pr	1	internal position control
	PtTt	10	external position control (with torque limitation function)
S (speed control)	S	2	speed control (without zero fixed function)
	Szero	5	speed control (with zero fixed function)
T (torque control)	T	3	torque control (without zero fixed function)
	Tzero	4	torque control (with zero fixed function)
Multiple mode	Pt_Szero	6	speed control (with zero fixed function) transferring to external position control
	Pt_Tt	7	External position control transferring to torque control
	Pt_Si	8	Internal position switching with internal speed
	Pt_Tr1	16	external position transferring to external torque control
	Pt_Tr2	17	external position transferring to internal torque control
test ways	Sr	11	speed test running
	JOG	12	JOG running
	OL	13	speed test mode
	OP	15	open loop running (only for factory)
encoder	CO	14	encoder zero-return (only for factory)

zero-return			
other ways	customized	18~100	Only for the special customers.

5. 2. Monitor states

At the layer 1 menu, to press key , can switch to monitor states, then by key  or  to select needed display mode, then display the specified states.

5. 2. 1. DSL200-P1 series (incremental 2500 lines)

grade 1 menu	function description	grade 21 menu	content	communication address (decimal)
Fn-01	current position low 4 bit (pulse)	P 5806	current position 145806 pulse	4×1281
Fn-02	current position high 4 bit (×10000 pulse)	P. 14		4×1282
Fn-03	position instruction low 4 bit (pulse)	C 5810	position instruction 145810 pulse	4×1283
Fn-04	position instruction high 4 bit (×10000 pulse)	C. 14		4×1284
Fn-05	position deviation low 4 bit (pulse)	E 4	position deviation 4 pulse	4×1285
Fn-06	position deviation high 4 bit (×10000 pulse)	E. 0		4×1286
Fn-07	position instruction pulse frequency (kHz)	F 12. 6	position instruction pulse frequency 12. 6kHz	4×1287
Fn-08	motor speed (r/min)	R 1000	motor speed 1000r/min	4×1288
Fn-09	speed analogue instruction input (V)	S 2. 5	speed analogue voltage 2. 5V	4×1289
Fn-10	speed analogue instruction input (rpm)	S. 750	speed analogue instruction 750r/min	4×1290
Fn-11	torque analogue instruction input (V)	T2. 5	torque analogue voltage 2. 5V	4×1291
Fn-12	torque analogue instruction input (%)	T. 25	torque analogue instruction 25%	4×1292
Fn-13	mean current (A)	I 2. 3	mean current 2. 3A	4×1293
Fn-14	peak current (A)	I. 3. 5	peak current 3. 5A	4×1294

Fn-15	motor feedback pulse (relative values)	A 3265	rotor absolute position value 3265	4×1295
Fn-16	motor feedback pulse (absolute values)	A. 0		4×1296
Fn-17	input terminals states	In 1111	input terminals	4×1297
Fn-18	output terminals states	Out 11	output terminals	4×1298
Fn-19	encoder input signals	Cod --	encoder signals	4×1299
Fn-20	servo run states	Rn 0n	running	4×1300
Fn-21	alarm code	Ale 9	No. 9 alarm	4×1301
Fn-22	external speed analogue voltage input display	U 0.000	external speed analogue voltage 0.000	4×1302
Fn-23	external torque analogue voltage input display	U 0.000	external torque analogue voltage 0.000	4×1303
Fn-24	servo alarm times memory	AC 8	servo alarm 8 times	4×1304

5.2.2. DSL200-P4 series (absolute 17 bits)

grade 1 menu	function description	grade 21 menu	content	communication address (decimal)
Fn-01	absolute encoder single circle low 4 bit	P 5806	encoder single circle data 145806	4×1281
Fn-02	absolute encoder single circle high 4 bit (×10000 pulse)	P. 12		4×1282
Fn-03	position instruction low 4 bit(pulse)	C 5810	position instruction 145810 pulse	4×1283
Fn-04	position instruction high 4 bit (×10000 pulse)	C. 14		4×1284
Fn-05	position deviation low 4 bit(pulse)	E 4	position deviation 4 pulse	4×1285
Fn-06	position deviation high 4 bit (×10000 pulse)	E. 0		4×1286
Fn-07	position instruction pulse frequency (kHz)	F 12.6	position instruction pulse frequency 12.6kHz	4×1287
Fn-08	motor speed(r/min)	R 1000	motor speed 1000r/min	4×1288

Fn-09	speed analogue instruction input (V)	S 2.5	speed analogue voltage 2.5V	4×1289
Fn-10	speed analogue instruction input (rpm)	S. 750	speed analogue instruction 750r/min	4×1290
Fn-11	torque analogue instruction input (V)	T2.5	torque analogue voltage 2.5V	4×1291
Fn-12	torque analogue instruction input (%)	T. 25	torque analogue instruction 25%	4×1292
Fn-13	mean current (A)	I 2.3	mean current 2.3A	4×1293
Fn-14	peak current (A)	I. 3.5	peak current 3.5A	4×1294
Fn-15	absolute encoder multi-circle low 4 bit	A 3265	encoder multi-circle data 43265	4×1295
Fn-16	absolute encoder multi-circle high 4 bit (×10000 pulse)	A. 4		4×1296
Fn-17	input terminals states	In 1111	input terminals	4×1297
Fn-18	output terminals states	Out 11	output terminals	4×1298
Fn-19	encoder input signals	Cod --	encoder signals	4×1299
Fn-20	servo run states	Rn 0n	running	4×1300
Fn-21	alarm code	Ale 9	No.9 alarm	4×1301
Fn-22	external speed analogue voltage input display	U 0.000	external speed analogue voltage 0.000	4×1302
Fn-23	external torque analogue voltage input display	U 0.000	external torque analogue voltage 0.000	4×1303
Fn-24	servo alarm times memory	AC 8	servo alarm 8 times	4×1304
Fn-25	servo motor original point position DATA0	137	① when P1-28=2 or I/O input pin is planned as SetAxis, and as OFF-->ON, motor origin point	4×1305
Fn-26	servo motor original point position DATA1	237		4×1306
Fn-27	servo motor original point position DATA2	254		4×1307

Fn-28	servo motor original point position DATA3	255	will be set. ② original point is -70262	4×1308
Fn-29	servo motor current position DATA0	208	current position is 350416	4×1309
Fn-30	servo motor current position DATA1	88		4×1310
Fn-31	servo motor current position DATA2	5		4×1311
Fn-32	servo motor current position DATA3	0		4×1312

Notices:

● Encoder signal-circle position information: $(Fn-16)*10000+(Fn-15)$. Encoder multi-circle position information: $(Fn-02)*10000+(Fn-01)$.

● Servo motor original point position: $((Fn-28)*16777216 + (Fn-27)*65536 + (Fn-26)*256+(Fn-25)) \& 0 \times 7FFFFFFF$

For example: Fn-28=255. Fn-27=254; Fn-26=237, Fn-25=137

Original point position= $(255*16777216 + 254*65536 + 237*256+137) \& 0 \times 7FFFFFFF=-70262$

● Servo motor current position: $((Fn-32)*16777216 + (Fn-31)*65536 + (Fn-30)*256+(Fn-29)) \& 0 \times 7FFFFFFF$

For example: Fn-32=0. Fn-31=5; Fn-30=88, Fn-29=208

Current position= $(0*16777216 + 5*65536 + 88*256+28) \& 0 \times 7FFFFFFF=350416$

● By communication mode, user can read absolute encoder original single-circle data and multi-circle data (Fn-02, Fn-01, Fn-16, Fn-15). Owing to encoder single-circle position being 0~131072, multi-circle position being 0~131072, after getting encoder original data, user should do zero-crossing processing to single-circle data and multi-circle data.

● For being more convenient to use, DSL200-P series servo driver has done internal processing to encoder data, by communication mode, user can directly read current position (Fn-32~Fn-29) and original point position (Fn-28 ~ Fn-25)

● Other monitor states definitions are same as those of DSL200-P1

5. 2. 3.Monitor parameters

parameters	function code	suitable ways	setting range	factory default value	unit	communication address (decimal system)
------------	---------------	---------------	---------------	-----------------------	------	--

P0-00	software version	PST		407	/	4×0000
P0-01	hardware version	PST		200	/	4×0001
P0-02	parameters default value recovery 0: no operation 1:to recover factory parameters setting 2:zero-point position setting for absolute encoder motor (only for factory)	PST	0~2	0	/	4×0002
P0-03	software reset 0: no operation 1: servo software reset	PST	0~1	0	/	4×0003
P0-04	previous alarm code 1	PST		0	/	4×0004
P0-05	previous alarm code 2	PST		0	/	4×0005
P0-06	previous alarm code 3	PST		0	/	4×0006
P0-07	previous alarm code 4	PST		0	/	4×0007
P0-08	previous alarm code 5	PST		0	/	4×0008

5.3. Extending Parameters

parameters	function code	suitable ways	setting range	factory default value	unit	communication address (decimal system)
P1-00	control mode selection. Specifics reference 5.7 "control mode definition table"	PST	0~100	0	/	4×256

P1-01	<p>direction setting of pulse instruction and encoder feedback output</p> <p>0: instruction pulse direction logical positive, encoder feedback direction logical positive</p> <p>1: instruction pulse direction logical negative, encoder feedback direction logical positive</p> <p>2: instruction pulse direction logical positive, encoder feedback direction logical negative</p> <p>3: instruction pulse direction logical negative, encoder feedback direction logical negative</p>	P	0~3	0	/	4×257
P1-02	<p>output mode setting of external pulse train instruction</p> <p>0: pulse + direction</p> <p>1: to recover factory parameters setting</p> <p>4: CCW/ CW pulse</p> <p>6: phase A/B pulse</p>	PST	0~7	0	/	4×258
P1-03	<p>control instruction input source setting</p> <p>0: control command terminal given</p> <p>1: control command ModBus RTU communications given (such as RS-232, RS-485)</p> <p>2: control command Can communication given</p>	PST	0~2	0	/	4×259

P1-04	internal servo start setting 0:servo prohibition 1:servo enable after finishing the parameters setting, need to press the key "SET" for 3 seconds, when display "SAVE", means save the parameters value, otherwise the modified values haven't been saved.	PST	0~1	0	/	4×260
P1-05	motor type code: when P0-02=1, servo freely recover factory default values according to motor type code	PST	0~100	2	/	4×261
P1-06	electronic gear ratio numerator(N)	P	1~32767	1	/	4×262
P1-07	electronic gear ratio numerator(N2)	P	1~32767	1	/	4×263
P1-08	electronic gear ratio numerator(N3)	P	1~32767	1	/	4×264
P1-09	electronic gear ratio numerator(N4)	P	1~32767	1	/	4×265
P1-10	electronic gear ratio denominator(M)	P	1~32767	1	/	4×266
P1-11	Detector output pulse amount setting	PST	0~32767	2500	P/r	4×267
P1-12	motor halt mode function 0: free halt, the time is long 1: inertia halt, the time is short 2: retaining	PST	0~2	0	/	4×268
P1-13	analog speed instruction Max. swiveling speed: the corresponding max speed based on analog input ±10	S	-6000~6000	3000	rpm	4×269
P1-14	analog torque instruction Max output	T	0~6000	100	rpm	4×270

P1-15	analog torque instruction Max output: the corresponding max torque based on analog input ± 10	T	0~500	100	%	4×271
P1-16	motor over-speed alarm detection threshold	PST	0~6000	3000	rpm	4×272
P1-17	hardware drift amount automatic correction of analog speed / torque input 0: no operation 1: hardware zero drift automatic correction of analog speed / torque input pass	ST	0~100	0	/	4×273
P1-18	hardware drift amount manual correction of analog speed input	S	-4096~ 4096	0	/	4×274
P1-19	hardware drift amount manual correction of analog torque input	T	-4096~ 4096	0	/	4×275
P1-20	analog speed input proportion gain	S	20~3000	1000	0.001	4×276
P1-21	analog speed instruction voltage positive gain	S	20~3000	1000	0.001	4×277
P1-22	analog speed instruction voltage negative gain	S	20~3000	1000	0.001	4×278
P1-23	zero speed analog instruction voltage clamping down	S	-6000~ 6000	20	5mV	4×279
P1-24	analog torque input proportion gain	T	20~3000	1000	0.001	4×280
P1-25	analog torque instruction voltage positive gain	T	20~3000	1000	0.001	4×281
P1-26	analog torque instruction voltage negative gain	T	20~3000	1000	0.001	4×282
P1-27	zero-speed torque analog instruction voltage clamping down	T	-6000~ 6000	20	/	4×283

P1-28	automatic back-to-origin mode switch 0: after servo obtaining the enable signals, need external I/O to trigger back to origin. 1. after servo obtaining the enable signals, return the origin automatically. 2. to set origin position, directly set the current position of the absolute encoder as the origin. to set it by incremental encoder is invalid.	PST	0~2	0	/	4×284
P1-29	origin regression mode	PST	0~15	0	/	4×285
P1-30	high-speed origin regression speed setting in the first stage	PST	-3000~3000	200	rpm	4×286
P1-31	low-speed origin regression speed setting in the second stage	PST	-3000~3000	50	rpm	4×287
P1-32	origin regression deviation rotating number	PST	0~32767	0	×10000	4×288
P1-33	origin regression deviation pulse number	PST	0~32767	0	pulse	4×289
P1-34	retaining		0~32767	0	pulse	4×290
P1-35	The delay time of positioning completely signal output	P	0~10000	0	0.1ms	4×291
P1-36	when position deviation value less than its pulse number, ZSPD signal output is "ON"	PST	0~100	10	pulse	4×292
P1-37	when the motor speed is more than this speed, SSPD signal output is ON	S	0~6000	2500	rpm	4×293

P1-38	digital I/O access pin DI1 function planning ① bit 2: access pin function planning code (specifics refer "4.4") ② bit 3: the corresponding servo I/O signal forced validity ③ bit 4: the corresponding servo I/O signal input reversely	PST	0~1135	1	/	4×294
P1-39	digital I/O access pin DI2 function planning (same as the above)	PST	0~1135	4	/	4×295
P1-40	digital I/O access pin DI3 function planning (same as the above)	PST	0~1135	5	/	4×296
P1-41	digital I/O access pin DI4 function planning (same as the above)	PST	0~1135	6	/	4×297
P1-42	digital I/O access pin DI5 function planning (same as the above)	PST	0~1135	7	/	4×298
P1-43	digital I/O access pin DI6 function planning (same as the above)	PST	0~1135	31	/	4×299
P1-44	digital I/O access pin DI7 function planning (same as the above)	PST	0~1135	24	/	4×300
P1-45	digital I/O access pin DI8 function planning (same as the above)	PST	0~1135	25	/	4×301
P1-46	digital I/O access pin DI9 function planning (same as the above)	PST	0~1135	26	/	4×302
P1-47	digital I/O access pin DO1 function planning ① bit 2: access pin function planning code (specifics refer "4.5") ② bit 3: forced validity ③ bit 4: output electric level take reverse ④output signal is open	PST	0~1135	1	/	4×303

	circuit, positive terminal connecting the input port of master computer, negative terminal connecting 0V of master computer					
P1-48	digital I/O access pin DO2 function planning (same as the above)	PST	0~1135	2	/	4×304
P1-49	digital I/O access pin DO3 function planning (same as the above)	PST	0~1135	3	/	4×305
P1-50	digital I/O access pin DO4 function planning (same as the above)	PST	0~1135	4	/	4×306
P1-51	digital I/O access pin DO5 function planning (same as the above)	PST	0~1135	5	/	4×307
P1-52	retaining					4×308
P1-53	retaining					4×309
P1-54	CN2 pulse feedback output origin select 0:encoder feedback 1:instruction pulse	PST	0~1	0	/	4×310
P1-55	retaining		0~12800	0	0.001	4×311
P1-56	inertial halt decay coefficient	PST	0~40	2	/	4×312
P1-57	inertial halt ways selection	PST	0~1	0	/	4×313
P1-58	motor type inexactness alarm shield 0: invalid 1:shield motor type inexactness alarm	PST	0~1	0	/	4×314
P1-59	multiple of motor admitted Max over load	PST	0~500	200	%	4×315
P1-60	motor rated current	PST	0~1000	60	0.1A	4×316
P1-61	the current sampling circuit allows Max current	PST	0~10000	2500	0.01A	4×317
P1-62	Main circuit under-voltage torque limit	PST	0~500	100	%	4×318
P1-63	Time release for main circuit under-voltage torque limit	PST	0~1000	100	ms	4×319

5.4. Basic Parameters

parameters	function code	suitable ways	setting range	factory default value	unit	communication address (decimal system)
P2-00	speed control gain speed control gain increases, can promote speed response performance ; but if the value is set too much, easily cause vibration and noise	PST	0~1280	155	0.1	4×512
P2-01	speed integral time constant speed integral time constant reduces, can promote speed response and reduce speed control error, but if the value is set too much, easily cause vibration and noise	PST	1~32767	150	0.1ms	4×513
P2-02	position control gain	PS	0~2000	280	0.01	4×514
P2-03	servo motor load inertia ratio	PST	0~1000	100	%	4×515
P2-04	position control feed-forward gain	P	0~1280	0	0.1	4×516
P2-05	cut-off frequency of feed-forward instruction low-pass filter	P	1~2000	300	Hz	4×517
P2-06	position over-difference detection range	P	0~32767	600	×100	4×518
P2-07	position over-difference detection range 0: don't shield position over-difference alarm 1: shield position over-difference alarm	P	0~1	0	/	4×519
P2-08	speed gain switching threshold at low speed	PST	0~6000	100	rpm	4×520
P2-09	speed gain switching coefficient	PST	0~500	100	%	4×521
P2-10	speed gain variation ratio	PS	0~500	100	%	4×522
P2-11	position gain variation ratio	P	0~500	100	%	4×523
P2-12	automatic tuning of expert parameters	PST	0~32	0	/	4×524
P2-13	current control proportion gain	PST	0~6000	750	0.001	4×525

P2-14	current integral time constant	PST	1~32767	130	0.1ms	4×526
P2-15	current detection low-pass filter coefficient	PST	1~2000	25	%	4×527
P2-16	speed detection low-pass filter coefficient	PS	1~2000	40	%	4×528
P2-17	speed integral separation point	PS	0~3000	100	rpm	4×529
P2-18	speed control gain variation radio	PST	100~500	100	%	4×530
P2-19	the third return origin speed	PST		50	rpm	4×531
P2-20	speed P and PI adjuster selection 0:PI adjuster common adjuster, when load inertia ratio is much, certain over-adjusting sometimes occurs 1:P adjuster when load inertia ratio is much, can use P adjuster to reduce over-adjusting 2:PDFF adjuster, between PI and P adjuster, can meet with the requirements about little speed over-adjusting and quick response	PS	0~2	0	/	4×532
P2-21	analog instruction low-pass filter cu-off frequency	ST	0~32767	10	0.1ms	4×533
P2-22	analog speed/ torque instruction average filter time	ST	0~32767	300	0.1ms	4×534
P2-23	position instruction smooth enable 0: invalid 1: position instruction smooth function open 2: retaining	P	0~2	0	/	4×535
P2-24	position instruction smooth filter coefficient	P	1~10000	200	/	4×536
P2-25	retaining		0~1000	0		4×537

P2-26	speed control accelerating time	PST	0~10000	300	ms	4×538
P2-27	speed control decelerating time / internal position control accelerating-decelerating time	PS	0~10000	100	ms	4×539
P2-28	reverse gap compensation: owing to the gap of the screw pitch there occur error in the process of servo motor rotating positively and reversely. It can compensate the reverse gap	P	-30000~30000	0	pulse	4×540
P2-29	servo response Max frequency	PST	10~600	200	Hz	4×541
P2-30	torque reach time servo dealing modes selection 0:output torque reach signal 1:output torque reach signal and servo motor halt motion	PST	0~1	0	/	4×542
P2-31	retaining					4×543
P2-32	power-on release switch time-delayed effective detection	PST	0~1	0	/	4×544
P2-33	electromagnetic brake opening delay time	PST	0~32767	1500	0.1ms	4×545
P2-34	electromagnetic brake closing delay time	PST	0~32767	10000	0.1ms	4×546
P2-35	frequency of notch filter 1	PST	10~1000	200	1Hz	4×547
P2-36	decrement of notch filter 1	PST	0~100	0	1Db	4×548
P2-37	frequency of notch filter 2	PST	10~1000	200	1Hz	4×549
P2-38	decrement of notch filter 2	PST	0~100	0	1Db	4×550
P2-39	incremental encoder Hall type selection	PST	0~6	0	/	4×551
P2-40	motor origin point signal deviation amount	PST	0~360	21	度	4×552
P2-41	motor pole pairs amount	PST	0~20	4		4×553
P2-42	retaining					4×554

P2-43	No. "ALE-23" alarm shield switch	PST	0~1			4×555
P2-44	IPM module alarm delay time	PST	0~100	20	0.1ms	4×556
P2-45	DI1 input filter time	PST	0~10000	10	0.1ms	4×557
P2-46	DI2 input filter time	PST	0~10000	10		4×558
P2-47	DI3 input filter time	PST	0~10000	10	0.1ms	4×559
P2-48	DI4 input filter time	PST	0~10000	10	0.1ms	4×560
P2-49	DI5 input filter time	PST	0~10000	10	0.1ms	4×561
P2-50	CCW / CW drive forbidding function switch	PST	0~1	0	/	4×562
P2-51	IPM module alarm electric level selection	PST	0~1	0	/	4×563
P2-52	speed output amplitude limiting 1	PST	100~2000	1000	0.001	4×564
P2-53	speed output amplitude limiting 2	PST	100~2000	1000	0.001	4×565
P2-54	current output amplitude limiting	PST	100~1000	950	0.001	4×566
P2-55	benchmark reference voltage	PST	1000~3000	1700	0.1V	4×567
P2-56	absolute encoder feedback output phase Z pulse width	PST	0~32767	30	pulse	4×568
P2-57	Absolute encoder position read command 1.read single-turn data 2.read multi-turn data 3.single-turn reset (only for factory) 4.multi-turn reset 5.delete the errors	PST	1~5	2	/	4×569
P2-58	Absolute encoder feedback output time pulse amount ahead of time	PST	0~32767	20	pulse	4×570
P2-59	DI6 input filter time	PST	0~10000	10	0.1ms	4×571
P2-60	DI7 input filter time	PST	0~10000	10	0.1ms	4×572
P2-61	DI8 input filter time	PST	0~10000	10	0.1ms	4×573
P2-62	DI9 input filter time	PST	0~10000	10	0.1ms	4×574

5.5. Communication Parameters

parameters	function code	suitable ways	setting range	factory default value	unit	communication address (decimal system)
P3-00	station No. setting	PST	1~127	1		4×768
P3-01	communication transmission ratio 0: 4800 1:9600 2: 19200 3:38400 4:57600 5:1M 6:2M 7: 2.5M	PST	0~7	3	/	4×769
P3-02	protocol 0: No check 1+8+N+1 1: odd check 1+8+O+1 2: even check 1+8+E +1 3: No check 1+8+N+2 4: odd check 1+8+O+2 5: even check 1+8+E +2	PST	0~5	0	/	4×770
P3-03	communication errors handling 0: alarm and stop instantly 1: alarm and decelerating to stop 2. continue running	PST	0~2	0	/	4×771
P3-04	communication overtime setting	PST	0~200	0	0.1s	4×772
P3-05	communication mode selection 0:RS-48: (MODBUS RTU) 1: retaining 2:RS-232 (free broadcast protocol) 3: RS-485 (free broadcast protocol) 4: CAN (CAN open protocol)	PST	0~4	0	/	4×773
P3-06	servo communication response delay time	PST	0~1000	20	0.1s	4×774

5. 6. Spreading Parameters

parameters	function code	suitable ways	setting range	factory default value	unit	communication address (decimal system)
P4-00	servo motor JOG control	JOG	0~6000	0	rpm	4×1024
P4-01	given speed under the way of test	OL	-6000~6000	100	rpm	4×1025
P4-02	speed trial running start speed	Sr	-6000~6000	0	rpm	4×1026
P4-03	open loop running voltage	OP	0~31000	1395	0.01V	4×1027
P4-04	open loop running speed	OP	0~3000	18	rpm	4×1028
P4-05	internal position automatic motion and external input selection	Pr	0~1	0	/	4×1029
P4-06	internal torque-speed limitation 1	T	-6000~6000	300	rpm	4×1030
P4-07	internal torque-speed limitation 2	T	-6000~6000	600	rpm	4×1031
P4-08	internal torque-speed limitation 3	T	-6000~6000	1000	rpm	4×1032
P4-09	internal torque instruction 1/ internal torque limitation 1	T	0~500	15	%	4×1033
P4-10	internal torque instruction 2/ internal torque limitation 2	T	0~500	20	%	4×1034
P4-11	internal torque instruction 3/ internal torque limitation 3	T	0~500	20	%	4×1035
P4-12	The position turns setting of internal torque instruction 1	Pr	0~32767	20	× 10000	4×1036
P4-13	The position pulses setting of internal torque instruction 1	Pr	0~32767	0	pulse	4×1037
P4-14	The speed setting of internal torque instruction 1	Pr	-4000~ 4000	100	rpm	4×1038
P4-15	The position turns setting of internal torque instruction 2	Pr	0~32767	40	× 10000	4×1039
P4-16	The position pulses setting of internal torque instruction 2	Pr	0~32767	0	pulse	4×1040
P4-17	The speed setting of internal torque instruction 2	Pr	-4000~ 4000	200	rpm	4×1041

P4-18	The position turns setting of internal torque instruction 3	Pr	0~32767	50	×	10000	4×1042
P4-19	The position pulses setting of internal torque instruction 3	Pr	0~32767	0		pulse	4×1043
P4-20	The speed setting of internal torque instruction 3	Pr	-4000~ 4000	300		rpm	4×1044
P4-21	The position turns setting of internal torque instruction 4	Pr	0~32767	20	×	10000	4×1045
P4-22	The position pulses setting of internal torque instruction 4	Pr	0~32767	0		pulse	4×1046
P4-23	The speed setting of internal torque instruction 4	Pr	-4000~ 4000	500		rpm	4×1047
P4-24	The position turns setting of internal torque instruction 5	Pr	0~32767	20	×	10000	4×1048
P4-25	The position pulses setting of internal torque instruction 5	Pr	0~32767	0		pulse	4×1049
P4-26	The speed setting of internal torque instruction 5	Pr	-4000~ 4000	-500		rpm	4×1050
P4-27	The position turns setting of internal torque instruction 6	Pr	0~32767	50	×	10000	4×1051
P4-28	The position pulses setting of internal torque instruction 6	Pr	0~32767	0		pulse	4×1052
P4-29	The speed setting of internal torque instruction 6	Pr	-4000~ 4000	-300		rpm	4×1053
P4-30	The position turns setting of internal torque instruction 7	Pr	0~32767	40	×	10000	4×1054
P4-31	The position pulses setting of internal torque instruction 7	Pr	0~32767	0		pulse	4×1055
P4-32	The speed setting of internal torque instruction 7	Pr	-4000~ 4000	-200		rpm	4×1056
P4-33	The position turns setting of internal torque instruction 8	Pr	0~32767	20	×	10000	4×1057
P4-34	The position pulses setting of internal torque instruction 8	Pr	0~32767	0		pulse	4×1058
P4-35	The speed setting of internal torque instruction 8	Pr	-4000~ 4000	-100		rpm	4×1059
P4-36	automatic running mode timer 1	Pr	0~10000	0		10ms	4×1060
P4-37	automatic running mode timer 2	Pr	0~10000	0		10ms	4×1061
P4-38	automatic running mode timer 3	Pr	0~10000	0		10ms	4×1062
P4-39	automatic running mode timer 4	Pr	0~10000	0		10ms	4×1063

P4-40	automatic running mode timer 5	Pr	0~10000	0	10ms	4×1064
P4-41	automatic running mode timer 6	Pr	0~10000	0	10ms	4×1065
P4-42	automatic running mode timer 7	Pr	0~10000	0	10ms	4×1066
P4-43	automatic running mode timer 8	Pr	0~10000	10	10ms	4×1067
P4-44	internal speed control given 1	S	-6000~6000	100	rpm	4×1068
P4-45	internal speed control given 2	S	-6000~6000	200	rpm	4×1069
P4-46	internal speed control given 3	S	-6000~6000	300	rpm	4×1070
P4-47	internal speed control given 4	S	-6000~6000	0	rpm	4×1071
P4-48	internal speed control given 5	S	-6000~6000	-300	rpm	4×1072
P4-49	internal speed control given 6	S	-6000~6000	-200	rpm	4×1073
P4-50	internal speed control given 7	S	-6000~6000	-100	rpm	4×1074
P4-51	delay time of under-voltage alarm in major loop	PST	0~10000	20	0.1s	4×1075
P4-52	delay time of over-current alarm	PST	0~200	1	0.05s	4×1076

5. 7. Planning table of I/O digital input(DI) function codes

setting value	symbol	function name	function description	trigger ways	running mode
1	SON	servo start	OFF-servo motor enable forbidden ON- servo motor electrifying enable	level triggered	PST
2	ALRS	alarm reset signal	the failure can be divided into reset fault and non-resetting fault. This function can be used to dear the alarm or reset system after troubleshooting.	edge triggered	PST

3	SHOLD	internal speed command cease temporarily	during internal speed running, when the signal is effect, servo motor decelerates to stop	electric level triggers	S
4	P-OT	prohibiting positive direction drive	when mechanical moving exceeds the movable range, and starts the overrun prevention function ON-to prohibit positive direction drive OFF-to permit positive direction drive	electric level triggers	PST
5	N-OT	prohibiting negative direction drive	when mechanical moving exceeds the movable range, and starts the overrun prevention function ON-to prohibit negative direction drive OFF-to permit negative direction drive	electric level triggers	PST
6	RIL	positive direction external torque limitation	①when RIL= ON and FIL=OFF, positive direction torque limitation ②when RIL= OFF and FIL=ON, negative direction torque limitation ③in other situation, both positive and negative direction will be in external torque limitation	electric level triggers	PST
7	FIL	negative direction external torque limitation		electric level triggers	PST
8	PCLR	clearing out pulse errors to zero	ON-to clear out servo motor's retention pulse, servo stops instantly OFF-after detaining the instruction pulse, servo operation stop automatically	Edge/ electric level triggers	P
9	LOK	clamp in zero speed	ON-clamp in zero speed, don't receive any speed analog voltage, motor is in the condition of zero speed. OFF-receive external analog voltage, motor running at the speed that given voltage instruction	electric level triggers	ST
10	SPD1	internal speed select 1	for speed multi-stage switching function	electric level triggers	ST
11	SPD2	internal speed select 2			
12	SPD3	internal speed select 3			
13	MDC	control mode switching	for multi-modes switching	electric level triggers	PST

14	INH	Position command prohibition	ON-to permit external instruction pulse input OFF-to prohibit external instruction pulse input					electric level triggers	PT
15	SPDINV	speed control direction reversely	ON-instruction reverse direction OFF-default instruction direction					electric level triggers	ST
16	G-SEL	speed gain switching	ON-speed gain switching, switching coefficient refer P2-09 OFF-system default control					electric level triggers	PST
17	GN1	electronic gear ratio numerator select 1	GN1	GN2	GN3	GN4	numerator	electric level triggers	P
			0	0	0	0	P1-06		
18	GN2	electronic gear ratio numerator select 2	0	1	0	0	P1-07		
35	GN3	electronic gear ratio numerator select 3	0	0	1	0	P1-08		
36	GN4	electronic gear ratio numerator select 4	0	0	0	1	P1-09		
19	PTRG	internal position trigger	multi-section position trigger condition					edge triggers	Pr
20	PHOLD	internal position stop temporarily	When internal position running ON-stop temporarily, OFF-running continuously					electric level triggers	Pr
21	SHOME	starts to return the zero-point	triggers the servo to zero-point					edge triggers	PST
22	ORG1	proximity switch signal 1	when the servo returns to the zero-point and ORG1 is effective, servo begins to decelerate or stop, details refer the introduction of servo zero-return control (section 4.6)					Edge/electric level trigger	PST
23	ORG2	proximity switch signal 2	when the servo returns to the zero-point and ORG2 is effective, servo begins to decelerate or stop, details refer the introduction of servo zero-return control (section 4.6)					Edge/electric level trigger	PST
24	POS1	internal speed select 1	for position multi-section switch function, at present DSL300 only selects 8 sections of position, if need to run more sections of position, factory can					electric level trigger	Pr
25	POS2	Internal speed select 2							

26	POS3	internal speed select 3	customize.				
27	POS4	internal speed select 4					
28	TTRINV	torque command negative direction	ON-instruction negative direction; OFF-default instruction direction			electric level trigger	T
31	EMC	emergency stop	ON-emergency stop; OFF-running continuously			electric level trigger	PST
33	JOG+	positive direction jog	ON-to input according to the given instruction; OFF-running instruction stop input			electric level trigger	S
34	JOG-	negative direction jog	ON-to input according to the given instruction; OFF-running instruction stop input			electric level trigger	S
37	MPD0	internal position control manual/automatic switch	ON-manual running OFF-automatic running			electric level trigger	Pr
38	MD0	internal position control manual speed select 1	MD0	MD1	speed	electric level trigger	Pr
			0	1	P4-45		
39	MD1	internal position control manual speed select 2	0	0	0		Pr
			1	1	0		
40	SetAxis	coordinate origin setting	to set the origin position of servo motor ()			edge trigger	PST

5. 8. Planning table of I/O digital output(DO) function codes

setting value	symbol	function name	function description	running mode
1	SRDY	servo be ready for	output signal after servo initialization	PST
2	ALRM	servo alarm	output signal when servo in failure	PST
3	ZSPD	position reach	the output signals, when the amount of remnant pulse less than or equal to P1-36 setting value	P
4	TSPD	torque reach	the output signals when the torque output value reaches the setting value	T
	SSPD	speed reach	the output signals when the speed value reaches P1-37 the setting value	S

	HOME	servo zero-return completion	the output signals when the servo motor zero-return completion	PST
5	BRKR	brake signals output	brake signal output, effective-close	PST

5.9. Definition table for servo zero-return mode

5.9.1. The zero-return features of DSL200-P series

The zero-return features of DSL200-P series are shown as the following.

- ◆ operating easily, the accuracy of returning zero repeatedly is high, no need the master computer to interfere, to simplify the zero-return operation of master computer.
- ◆ zero-return operation can't start until the servo obtains the enable.
- ◆ zero-return operation has the priority, when the it meet the condition of zero-return, servo motor perform zero-return operation immediately. After turn on the power, multi-times of zero-return can be done.
- ◆ after P1-28 is set to 1, when turn on the power, servo can perform zero-return operation automatically. After finishing zero-return, it automatically starts the P1-00 control mode.
- ◆ when finishing zero-return operation, the signal fixed width is 100ms.

There are some difference of zero-return between incremental encoder and absolute encoder. They are introduced separately below.

5.9.2. DSL200-P series (2500 line incremental encoder)

P1-29	definition of zero-return mode	description of zero-return process
0/1/2/3	DOG test+ Z pulse	<p>① when setting P1-28 to be 1 or the I/O input pin plan is SHOME and it is effective, servo motor returns to zero firstly at the speed of P1-30 setting value (high speed).</p> <p>②when the I/O input pin plan is ORG1 and it is effective, servo motor detects Z pulse at the speed of P1-31 setting value (low speed).</p> <p>③ when Z pulse appears, servo motor stop running, then zero-return completes.</p> <p>④when zero-return completes signal, it automatically starts control mode of P1-00 setting value.</p>

4	double DOG test+Z pulse	<p>① when setting P1-28 to be 1 or the I/O input pin plan is SHOME and it is effective, servo motor returns to zero firstly at the speed of P1-30 setting value (high speed).</p> <p>② there are two circumstances in the below.</p> <ul style="list-style-type: none"> ●when the I/O input pin plan is ORG1 and it is effective firstly, servo motor detects Z pulse at the speed of P1-31 setting value (low speed). When Z pulse are tested, servo motor stop running, the zero-return is completed. the zero-return completion signals are outputted synchronously. and it automatically starts the control mode of P1-00 setting. ●when the I/O input pin plan is ORG2 and it is effective firstly, servo motor reversely detects ORG1 signals at the speed of P1-30 setting value (high speed). when ORG1 signals are effective, servo motor begins to detect Z pulse at the speed of P1-31 setting value (low speed). When Z pulse are tested, servo motor stop running, the zero-return is completed. the zero-return completion signals are outputted synchronously. and it automatically starts the control mode of P1-00 setting.
6	Z pulse + deviation amplitude	<p>① When setting P1-28 to be 1 or the I/O input pin plan is SHOME and it is effective, servo motor detects Z pulse signals firstly at the speed of P1-31 setting value.</p> <p>②When the Z pulse signal are detected, then servo motor runs one deviation amplitude pulse ($P1-32 \times 10000 + P1-33$) according to the P2-19 setting value (the third zero-return speed)</p> <p>③ after deviation amplitude of pulses have been finished., motor stops, returning zero completes, simultaneously zero-return completion signals are outputted and automatically starts the control mode P1-00 setting.</p>
8/9	DOG test + Z pulse +deviation amplitude	<p>① when setting P1-28 to be 1 or the I/O input pin plan is SHOME and it is effective, servo motor returns to zero firstly at the speed of P1-30 setting value (high speed).</p> <p>②when the I/O input pin plan is ORG1 and it is effective, servo motor detects Z pulse at the speed of P1-31 setting value (low speed).</p> <p>③ when the Z pulse signals are detected, then servo motor runs one deviation amplitude pulse ($P1-32 \times 10000 + P1-33$) according to the P2-19 setting value (the third zero-return speed)</p> <p>④after deviation amplitude of pulses have been finished., motor stops, returning zero completes, simultaneously zero-return completion signals are outputted and automatically starts the control mode P1-00 setting.</p>
10	DOG test (trigger electric level)	<p>①when setting P1-28 to be 1 or the I/O input pin plan is SHOME and it is effective, servo motor returns to zero firstly at the speed of P1-30 setting value (high speed).</p> <p>②when the I/O input pin plan is ORG1 and it is effective, motor stops, returning zero completes, simultaneously zero-return completion signals are outputted and automatically starts the control mode P1-00 setting.</p>

11	DOG test (rising edge)	<p>①when setting P1-28 to be 1 or the I/O input pin plan is SHOME and it is effective, servo motor returns to zero firstly at the speed of P1-30 setting value (high speed).</p> <p>②when the I/O input pin plan is ORG1 and from OFF to ON, motor stops, returning zero completes, simultaneously zero-return completion signals are outputted and automatically starts the control mode P1-00 setting.</p>
12	DOG test + torque	<p>①when setting P1-28 to be 1 or the I/O input pin plan is SHOME and it is effective, servo motor returns to zero firstly at the speed of P1-30 setting value (high speed).</p> <p>②the output torque of servo motors more than or equal to P4-09 setting value, servo motor begin to detect Z pulse at the speed of P1-31 setting value (low speed).</p> <p>③ when Z pulses are detected, servo motor stop running, then zero-return completes.</p> <p>④when zero-return completes signal, it automatically starts control mode of P1-00 setting value.</p>

5.9.3. DSL200-P4 series (17 bit absolute encoder)

P1-29	definition of zero-return mode	description of zero-return process
0	multi-circles absolute coordinate setting returning zero	<p>① before return zero, to make the servo motor to be in zero-point, then set P1-28 to be 2 or set I/O input pin plan to be SetAxis, and when it is from OFF to ON, directly designate the encoder point to be zero-return origin.</p> <p>②when setting P1-28 to be 1 or the I/O input pin plan is SHOME and it is effective, servo motor automatically returns to zero firstly at the speed of P1-29 setting value.</p> <p>③ servo motor stops, returning zero completes, simultaneously zero-return completion signals are outputted and automatically starts the control mode P1-00 setting.</p>
1	single-circle absolute coordinate setting returning zero	<p>① before return zero, to make the servo motor to be in zero-point (within one circle), then set P1-28 to be 2 or set I/O input pin plan to be SetAxis, and when it is from OFF to ON, directly designate the encoder point to be zero-return origin.</p> <p>②when setting P1-28 to be 1 or the I/O input pin plan is SHOME and it is effective, servo motor automatically returns to zero firstly at the speed of P1-29 setting value.</p> <p>③ servo motor stops, returning zero completes, simultaneously zero-return completion signals are outputted and automatically starts the control mode P1-00 setting.</p>
2	multi-circles absolute coordinate setting returning zero + DOG	<p>① before return zero, to make the servo motor to be in zero-point, then set P1-28 to be 2 or set I/O input pin plan to be SetAxis, and when it is from OFF to ON, directly designate the encoder point to be zero-return origin.</p> <p>②when setting P1-28 to be 1 or the I/O input pin plan is SHOME and it is effective, servo motor automatically returns to zero firstly at the speed of P1-30 setting value.</p> <p>③ when I/O input pin plan is ORG1 and effective, servo motor ceases 1m, then return the origin at the speed of P2-19 setting value</p> <p>④ servo motor stops, returning zero completes, zero-return completion signals are outputted and automatically starts the control mode P1-00 setting.</p>

3	single-circles absolute coordinate setting returning zero + DOG	<p>① before return zero, to make the servo motor to be in zero-point(within 1 circle), then set P1-28 to be 2 or set I/O input pin plan to be SetAxis, and when it is from OFF to ON, directly designate the encoder point to be zero-return origin.</p> <p>②when setting P1-28 to be 1 or the I/O input pin plan is SHOME and it is effective, servo motor automatically returns to zero firstly at the speed of P1-30 setting value.</p> <p>③ when I/O input pin plan is ORG1 and effective, servo motor ceases 1m, then return the origin at the speed of P2-19 setting value</p> <p>④ servo motor stops, returning zero completes, zero-return completion signals are outputted and automatically starts the control mode P1-00 setting.</p>
---	---	--

Notes:

Encoder original point position and current position of DSL200 can be read by RS-232 or RS485, for the specific, please refer to **Monitor states**.

5.10 Controlling Modes Definition Table

DSL200 series have various in-built control modes, user can select the different control mode by setting P1-100 value as following table.

P1-00	control mode	mode content	mode description	remark
0	Pt	external position control	external pulse instruction input	
1	Pr	internal position control	<p>①internal parameters input, to select running speed and position according to the pin plan of POS1, POS2, POS3</p> <p>②internal position control has JOG function</p>	
2	S	speed control (without origin-fixed function)	<p>①when SPD1, SPD2, SPD3 all are OFF, speed can be controlled by V-REF (CN2_3) analog voltage</p> <p>② when any of SPD1, SPD2, SPD3 is ON, speed can be controlled by I/O signal to select parameters P4-44~P4-50.</p>	
3	T	torque control	<p>①when SPD1, SPD2, SPD3 all are OFF, torque can be controlled by T-REF (CN2_1) analog voltage, speed can be controlled by V-REF (CN2_3) analog voltage</p> <p>② when any of SPD1, SPD2, SPD3 is ON, torque can be controlled by parameter P4-09, speed can be controlled by I/O signal to select parameters P4-44~P4-50.</p>	

4	Tzero	torque control (with origin-fixed function)	<p>①when SPD1, SPD2, SPD3 all are OFF, motor is in the state of origin-fixed</p> <p>② when any of SPD1, SPD2, SPD3 is ON, torque can be controlled by T-REF (CN2_1) analog voltage, speed can be controlled by I/O signal to select parameters P4-44~P4-50.</p>	
5	Szero	speed control (with origin-fixed function)	<p>①when SPD1, SPD2, SPD3 all are OFF, speed can be controlled by V-REF (CN2_3) analog voltage</p> <p>② when any of SPD1, SPD2, SPD3 is ON, speed can be controlled by I/O signal to select parameters P4-44~P4-50.</p>	
6	Pt_Szero	speed control (with Zero fixed function) transfer external position control	<p>①to switch Ps and Pt for MDC according to I/O pin function plan</p> <p>②when MDC=0, and SPD1, SPD2, SPD3 all are OFF, speed is controlled by V-REF (CN2-3) analog voltage.</p> <p>③when MDC=0, and when any of SPD1, SPD2, SPD3 is ON, speed can be controlled by I/O signal to select parameters P4-44~P4-50.</p> <p>④when MDC=1, it is controlled by the external pulse position.</p>	
7	Pt_Tt	external position control transfer torque control	<p>①to switch Pt and T for MDC according to I/O pin function plan</p> <p>②when MDC=0, it is controlled by the external pulse position.</p> <p>③when MDC=1, and when any of SPD1, SPD2, SPD3 is OFF, torque can be controlled according to T-REF (CN2_1) analog voltage, speed can be controlled according to V-REF (CN2_3) analog voltage.</p> <p>④when MDC=1, and when any of SPD1, SPD2, SPD3 is ON, torque can be controlled according to T-REF (CN2_1) analog voltage, speed can be controlled by I/O signal to select parameters P4-44~P4-50.</p>	
8	Pr_Si	Switch between internal position and internal speed	<p>①to switch Pr and Si for MDC according to I/O pin function plan</p> <p>②when MDC=0, it is controlled by the internal speed, internal speed is chosen according to the combination of SPD1, SPD2, SPD3 I/O pin plan.</p> <p>③when MDC=1, it is controlled by the internal speed, the running position and speed are chosen according to the combination of SPD1, SPD2, SPD3 I/O pin plan.</p>	
10	PtTt	Position control with torque-limited function	<p>①position and speed are controlled by external pulse instruction.</p> <p>②torque adjusting is controlled according to T-REF(CN2_1) input analog voltage.</p>	

11	Sr	speed trial running	P4-02 can adjust motor running speed, parameters don't save after cut off the power	
12	JOG	JOG running	P4-00 can adjust motor running speed, parameters don't save after cut off the power	
13	OL	test mode	P4-01 can adjust motor running speed, parameters don't save after cut off the power	
14	CO	encoder zero-adjusted	Mainly for zero-point magnetic pole position adjusting of absolute encoder motor, only for factory.	
15	OP	Open operation	only for factory.	
16	Pt_Tt	External position transfer torque control	<p>①to switch Pt and Tt for MDC according to I/O pin function plan</p> <p>②when MDC=0, it is controlled by the external pulse position.</p> <p>③when MDC=1, it is controlled by the external torque control, the torque is given according to the external analog voltage input pin T-REF(CN2_1).</p>	

Chapter 6 Electrification Operation

Notices:

- Drive unit and motor must ground reliably, the ground wire between the terminals and device must be connected reliably .
- The power of drive unit is suggested to be provided by isolation transformer and power filter so as to ensure the safety and anti-interference ability.
- Must check and ensure that the connecting is right firstly, then turn on the power.
- Must connect one emergency stop circuit, to ensure that the power can stop immediately when the failure occurs.(refer the diagram)
- After drive unit failure alarms, before re-start them, must confirm that the failures are have removed, SON signals are ineffective.

6.1 Power supply connecting

6.1.1. Connecting methods

- ◆ To connect the power supply with main circuit power input terminals (three phase connecting R,S,T; single phase connecting R, S) electromagnetic contactor.
- ◆ Power terminal R,S of control circuit connection should be coinstantaneous with or prior to main circuit, if only connecting the power of control circuit, servo be ready for signal (SRDY) OFF.
- ◆ After connecting main circuit power, delays about 1.5s, servo be ready for signal (SRDY)ON, this moment, can accept servo enable (SON) signal, after detecting servo enable be effective, driver output be valid, motor excitation, be in the state of running. When detect servo enable be invalid or alarm, base pole circuit shut off, motor is in the state of free.
- ◆ When servo enable connecting with power supply, base pole circuit will be electrified about 1.5s later.
- ◆ Frequently switching power supply maybe damages the soft-start circuit and energy-consuming-brake circuit, the frequency of switch is best to be limited within 5 times each hour, below 30 times each day. If drive unit or motor be over-heat, after troubleshooting, there are still need 30minutes to cool down, then connect the power supply again.

6.1.2. Before running, please check the following questions again

- ◆ Whether is power supply terminals TB wiring correct? Whether is the reliable input voltage correct?
- ◆ Whether do the wire of power supply and motor short or ground?
- ◆ Whether is the encoder cable connecting correct?
- ◆ Whether does control signal terminals connect correctly?
- ◆ Whether are the power supply polarity and size correct?
- ◆ Whether do drive unit and motor fix firmly?
- ◆ Whether does the motor shaft connect load?

Please confirm that all above questions are be solved before running.

6.1.3. Power supply electrifying sequence diagram

Power supply electrifying sequence diagram

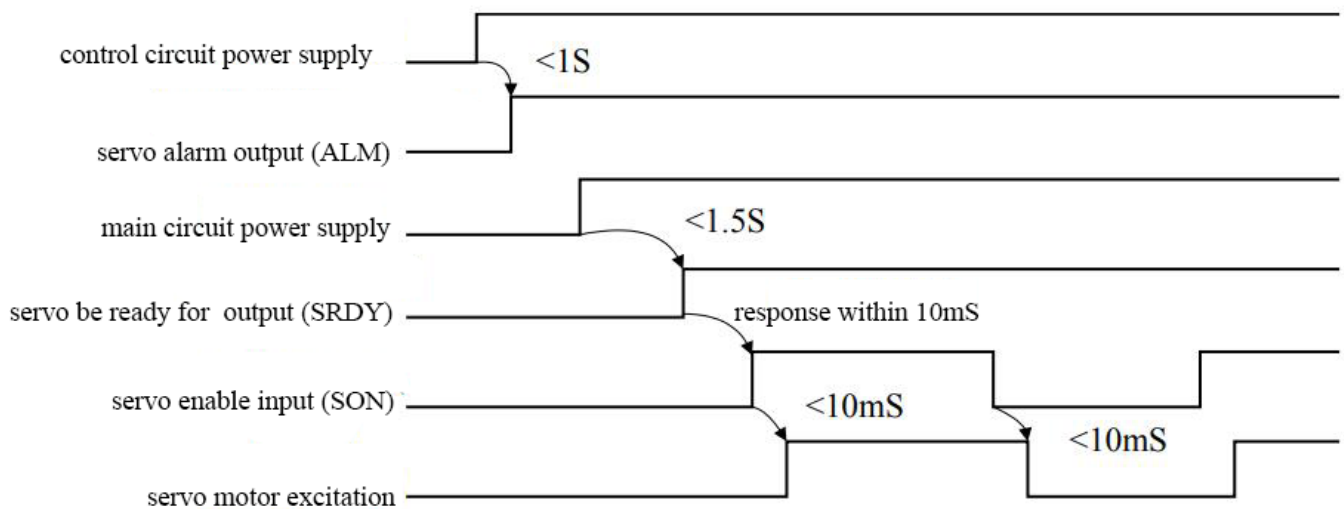

6.1.4. Power supply electrifying sequence diagram

Alarm sequence diagram

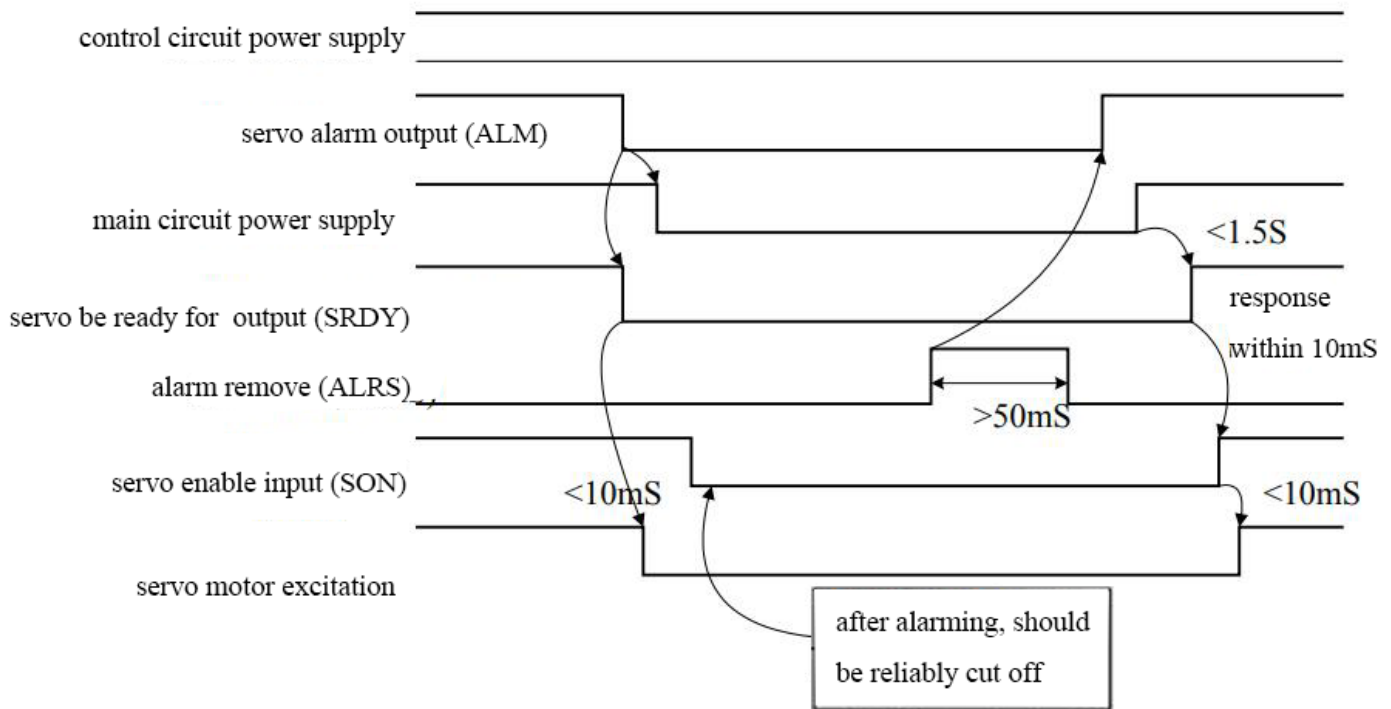

6.2 Speed trial operation

Notices:

- To suggest the speed trial operation and GOG operation have been done when the motor is in the situation of free-load so as to avoid the accidents from the devices.
- When the trial operation is done, the drive(servo enable) must be effective, the drive prohibition of CCW and CW must be ineffective .

6.2.1. Operation setting

Speed trial operation prompt is "S", the value unit is r/min, can set the speed trial operation mode according to the following ways.

- ◆ To set P1-00=11, make servo working in the mode of speed trial running.
- ◆ According to the external signals to enable servo or to set internal enable parameter P1-04=1.
- ◆ To go to parameter P4-02, use key , to adjust speed instruction, in this moment, parameter only shows the display state to be .

◆ Motor runs at the given speed. ▲ control speed positive increase, ▼ control speed positive reduce (reversely, increase). When display speed is positive value, motor rotates positively ; When display speed is negative value, motor rotates reversely.



6.2.2. Parameters setting

necessary parameter	Name	unit	parameter range	default	suitable mode
P1-00	input source setting of mode and control instruction		0∞15	11	P,S,T
P4-02	starting value of speed instruction	Rpm	-3000∞3000	0	S
P2-26	acceleration-deceleration smooth constant in S-type smooth curve	Ms	0∞32767	300	S
P1-04	internal enable		0∞1	0	P,S,T

6.3 JOG running

6.3.1. JOG run setting

The unit of JOG running is r/min, can start JOG operation mode according to the following setting.

- ◆ To set P1-00=12, make servo working in the mode of JOG running mode.
- ◆ According to the external signals to enable servo or to set internal enable parameter P1-04=1.
- ◆ To go to parameter P4-00, press key , to display JOG speed. Starting value is 0 r/min.
- ◆ To press key ▲, ▼ to adjust JOG speed value such as P4-00=100 meaning 100r/min.
- ◆ To press key , to start JOG mode. Then to press key ▲ or ▼ to make servo motor rotating in the positive or negative direction. Open the press, servo motor stops running immediately.

6.3.2. Parameters setting

necessary parameter	Name	unit	parameter range	default	suitable mode
P1-00	input source setting of mode and control instruction		0∞15	12	P,S,T
P4-00	JOG	Rpm	0∞6000	100	S
P2-26	acceleration-deceleration smooth constant in S-type smooth curve	Ms	0∞32767	300	S
P1-04	internal enable		0∞1	0	P,S,T

6.4 Trial operation

To start the parameter mode setting P1-00=13. Then to enter P4-01, can test the operation mode of motor according to the following setting. Motor test prompt is “r”, the unit is r/min. the system is in the way of position control mode. Position limiting value is 268435456 pulse. Speed is set by the parameter P4-01. After starting the motor test operation, press the key, then the motor can run.

necessary parameter	Name	unit	parameter range	default	suitable mode
P1-00	input source setting of mode and control instruction		0∞15	13	P,S,T
P4-01	given speed in the test way	Rpm	-3000∞3000	0	0L
P2-26	acceleration-deceleration smooth constant in S-type smooth curve	Ms	0∞32767	300	S
P1-04	internal enable		0∞1	0	P,S,T

Notice:

When carrying out speed trial operation and JOG operation, if there are some abnormalities like vibration, noise, need to debug velocity parameters such as P2-00, P2-01, P2-16 etc. About the details, please refer the parameters explanation in Chapter 5.

6.5 Position mode running

6.5.1 External position instruction running

6.5.1.1 Running methods

- ◆ To connect CN2 to make input control signal: servo enable (SON) to be OFF.
- ◆ To connect control circuit power (not connect main circuit power temporarily), the displayer of drive unit turns on. If alarm occurs, please check the wiring.
- ◆ To set control mode selection (parameter P1-00) as location running mode (making it is 0), and set suitable electronic gear ratio (P1-06∞P1-10).
- ◆ To select external location instruction pulse input mode P1-02; direction control P1-01.
- ◆ To connect main circuit power.
- ◆ After confirming no alarms and any other abnormalities, make servo enable (SON) to be ON. the motor excited and be in the status of zero speed.

- ◆ To operate the location controller output signal to be drive pin CN2-49, 50, 25, 24, to make motor to rotate according to instruction.
- ◆ Under the status of monitoring, Fn-1 and Fn-2 can display encoder feedback present pulse value, Fn-3 and Fn-4 can display master computer location instruction pulse input value.

6.5.1.2 Parameters setting

necessary parameter	Name	unit	parameter range	default	suitable mode
P1-00	input source setting of mode and control instruction		0∞15	0	P,S,T
P1-01	input polarity setting of external pulse range instruction		0∞3	0	Pt
P1-02	input form setting of external pulse range instruction		0∞7	0	Pt
P1-06	electronic gear ratio(N1)		1∞32767	1	Pt,Pr
P1-10	electronic gear ratio(M)		1∞32767	1	Pt,Pr
P1-23	location instruction smooth function selection		0∞1	0	Pt
P1-24	location instruction smooth filter coefficient		0∞100	5	Pt
P2-02	location control ratio gain	0.1	0∞2000	280	Pt
P2-04	location control feed-forward gain	%	0∞100	0	Pt
P2-00	speed control ratio gain	0.1	5∞1280	320	P,S,T
P2-01	speed integral time constant 1	0.1ms	1∞32767	150	P,S,T
P2-16	speed detection low pass filter coefficient	%	10∞10000	100	P,S,T

6.5.2 Internal position instruction running

6.4.2.1 Running methods

- ◆ To connect CN2, make input control signal : servo enable (SON) to be OFF.
- ◆ To connect control circuit power (not connect main circuit power temporarily), the displayer of drive unit turns on. If alarm occurs, please check the wiring.

- ◆ To set control mode selection (parameter P1-00) as location running mode (making it is 1), and set suitable electronic gear ratio (P1-06↔P1-10), if automatically running, can set P4-36↔P4-43, set stop time of each location stage.
- ◆ To correctly set P4-12↔P4-35 (running distance of each location stage, total 8 stages).
- ◆ To correctly set P4-26↔P4-35 (running speed of each location stage, total 8 stages).
- ◆ To correctly set P1-38↔P1-46 (I/O input multi-function plan).
- ◆ To correctly set P4-05, to choose whether the running location stage of internal position control is automatically running or external I/O.
- ◆ To connect main circuit power.
- ◆ After confirming no alarms and any other abnormalities, make servo enable (SON) being ON. the motor excited and being in the status of zero speed.
- ◆ Exchange the pin SC0-SC1 status of external I/O input terminals, to make servo to run different internal location instruction and speed. Under the status of monitoring, When I/O input pin is planned internal instruction trigger (control the parameter of pin is 19) and effective, servo works in the status of internal location control. Fn-1 and Fn-2 can display encoder feedback present pulse value, Fn-3 and Fn-4 can display master computer location instruction pulse input value.

6.5.2.2 Parameters setting

necessary parameter	Name	unit	parameter range	default	suitable mode
P1-00	input source setting of mode and control instruction		0↔30	1	Pt,S,T
P1-06	electronic gear ratio(N1)		1↔32767	1	Pt,Pr
P1-10	electronic gear ratio(M)		1↔32767	1	Pt,Pr
P4-12	location rotating number setting of internal location instruction 1	×10000	0↔32767	2	Pr
P4-13	location pulse number setting of internal location instruction 1	pulse	0↔10000	0	Pr
P4-15	location rotating number setting of internal location instruction 2	×10000	0↔32767	0	Pr
P4-16	location pulse number setting of internal location instruction 2	pulse	0↔10000	0	Pr

P4-18	location rotating number setting of internal location instruction 3	×10000	0~32767	0	Pr
P4-20	location pulse number setting of internal location instruction 3	pulse	0~10000	0	Pr
P4-22	location rotating number setting of internal location instruction 4	×10000	0~32767	0	Pr
P4-23	location pulse number setting of internal location instruction 4	pulse	0~10000	0	Pr
P4-24	location rotating number setting of internal location instruction 5	×10000	0~32767	0	Pr
P4-25	location pulse number setting of internal location instruction 5	pulse	0~10000	0	Pr
P4-26	location rotating number setting of internal location instruction 6	×10000	0~32767	0	Pr
P4-27	location pulse number setting of internal location instruction 6	pulse	0~10000	0	Pr
P4-28	location rotating number setting of internal location instruction 7	×10000	0~32767	0	Pr
P4-29	location pulse number setting of internal location instruction 7	pulse	0~10000	0	Pr
P4-30	location rotating number setting of internal location instruction 8	×10000	0~32767	0	Pr
P4-31	location pulse number setting of internal location instruction 8	pulse	0~10000	0	Pr
P4-14	motion speed setting of internal position/ speed instruction control 1	Rpm	-6000~6000	100	Pr,S
P4-17	motion speed setting of internal position/ speed instruction control 2	Rpm	-6000~6000	200	Pr,S
P4-20	motion speed setting of internal position/ speed instruction control 3	Rpm	-6000~6000	300	Pr,S
P4-23	motion speed setting of internal position/ speed instruction control 4	Rpm	-6000~6000	500	Pr,S
P4-26	motion speed setting of internal position/ speed instruction control 5	Rpm	-6000~6000	-500	Pr,S

P4-29	motion speed setting of internal position/ speed instruction control 6	Rpm	-6000~6000	-300	Pr,S
P4-32	motion speed setting of internal position/ speed instruction control 7	Rpm	-6000~6000	-200	Pr,S
P4-35	motion speed setting of internal position/ speed instruction control 8	Rpm	-6000~6000	-100	Pr,S
P1-29	origin regression model		0~15	0	Pt,S
P1-30	high speed origin regression setting of stage 1	Rpm	-3000~3000	200	Pt,S
P1-31	low speed origin regression setting of stage 2	Rpm	-3000~3000	5	Pt,S
P1-38	digital IO access pin D I1 function plan		0000~1135	1	Pt,S,T
P1-39	digital IO access pin D I2 function plan		0000~1135	22	Pt,S,T
P1-40	digital IO access pin D I3 function plan		0000~1135	19	Pt,S,T
P1-41	digital IO access pin D I4 function plan		0000~1135	6	Pt,S,T
P1-42	digital IO access pin D I5 function plan		0000~1135	7	Pt,S,T
P1-43	digital IO access pin D I6 function plan		0000~1135	31	Pt,S,T
P1-44	digital IO access pin D I7 function plan		0000~1135	24	Pt,S,T
P1-45	digital IO access pin D I8 function plan		0000~1135	25	Pt,S,T
P1-46	digital IO access pin D I9 function plan		0000~1135	26	Pt,S,T

6.5.3 The corresponding table of IO input pin and running speed

The corresponding table of IO input pin and running speed is below

CN2_19 (POS 3)	CN2_13 (POS 2)	CN2_10 (POS 1)	stage
OFF	OFF	OFF	stage 1
OFF	OFF	ON	stage 2
OFF	ON	OFF	stage 3
OFF	ON	ON	stage 4
ON	OFF	OFF	stage 5
ON	OFF	ON	stage 6

ON	ON	OFF	stage 7
ON	ON	ON	stage 8

Notice:

- ON means that IO input pin being given low electrical level is effective. OFF means that IO input pin being given high electrical level suspends.
- To correctly set P1-44=24, P1-45=25, P1-46=26.

6.6 Speed mode running**6.6.1 external analog voltage speed control mode****6.6.1.1 Connecting methods**

- ◆ To connect CN2, to make input control signal: servo enable (SON) being OFF, CCW drive prohibition (CCWL) being ON, CW drive prohibition (CWL) being ON.
- ◆ To connect control circuit power (not connect main circuit power temporarily), the displayer of drive unit turns on. If alarm occurs, please check the wiring.
- ◆ To set control mode selection (P1-00) as speed running mode (to be set as 2) and SC3 being OFF, SC2 being OFF, SC1 being OFF.
- ◆ To connect main circuit power.
- ◆ After confirming no alarms and any other abnormalities, make servo enable (SON) being ON. the motor excited and being in the running status of external analog voltage control speed.
- ◆ Analog speed voltage adjusting to be zero.

6.6.1.2 Being adjusted to zero manually

- ◆ To switch display mode with monitoring mode “Fn-8 ” (speed monitoring)
- ◆ Please observe the speed value on the displayer, if it is CW, go to the parameter mode to adjust the value of P1-8 towards the big value, if it is CCW, then adjust the value of P1-8 towards the small value till it displays “r-0”.

6.6.1.3 Being adjusted to zero automatically

- ◆ To switch display mode with monitoring mode “Fn-8 ” (speed monitoring)
- ◆ When to set P1-17 as 1, then it can adjust to zero automatically

6.6.1.4 Parameters setting

necessary parameter	Name	unit	parameter range	default	suitable mode
P1-00	input source setting of mode and control instruction		0~15	2	P,S,T
P2-21	cut-off frequency of analog speed/ torque instruction filter	Hz	0~32767	10	S,T
P2-00	speed control ratio gain	0.1	5~1280	320	P,S,T
P2-01	speed integral time constant 1	0.1ms	1~32767	150	P,S,T
P2-16	speed detection low pass filter coefficient	%	10~10000	100	P,S,T
P1-17	auto-adjusting function of analog speed/ torque input hardware drift		0~1	0	S
P1-18	manually-adjusting function of analog speed input hardware drift amount		-4096~4096	0	S
P1-20	analog speed input ratio gain		20~3000	1000	S
P1-21	analog instruction voltage positive direction gain		20~3000	1000	S
P1-22	analog instruction voltage negative direction gain		20~3000	1000	S

6.6.2 7 modes of internal control

6.6.2.1 Connecting methods

- ◆ To connect CN2, not to make all input control signals: servo enable (SON), speed selection 2 (SC2), speed selection 1 (SC1) and speed selection 0 (SC0) be being OFF, to make CCW drive prohibition (CCWL) being ON, to make CW drive prohibition (CWL) being ON.
- ◆ To connect control circuit power (not to connect main circuit power temporarily) , the display light of driver is on, if alarm occurs, please check the wiring.

- ◆ To make control mode select (parameter P1-00) setting as speed running mode (to be set as 2), to set speed parameters P4-44-P4-50 according to needs
- ◆ To connect main circuit power, after confirming that there have alarm and any abnormalities, to make servo enable (SON) being ON, in the case, motor being excited, it is in the internal speed running.
- ◆ To change the states of input signal SC2, SC1, SC0, to make motor running according to the designed speed.

6.6.2.2 Parameters setting

necessary parameter	Name	unit	parameter range	default	suitable mode
P1-00	input source setting of mode and control instruction		0~30	2	P,S,T
P2-21	cut-off frequency of analog speed/torque instruction filter	Hz	0~32767	10	S,T
P2-00	speed control ratio gain	0.1	5~1280	320	P,S,T
P2-01	speed integral time constant 1	0.1ms	1~32767	150	P,S,T
P2-16	speed detection low pass filter coefficient	%	10~10000	100	P,S,T
P4-44	moving speed setting of speed instruction control1	rpm	-6000~6000	100	S
P4-45	moving speed setting of speed instruction control2	rpm	-6000~6000	200	S
P4-46	moving speed setting of speed instruction control3	rpm	-6000~6000	300	S
P4-47	moving speed setting of speed instruction control4	rpm	-6000~6000	0	S
P4-48	moving speed setting of speed instruction control5	rpm	-6000~6000	-300	S
P4-49	moving speed setting of speed instruction control6	rpm	-6000~6000	-200	S
P4-50	moving speed setting of speed instruction control7	rpm	-6000~6000	-100	S
P1-26	acceleration / deceleration time	ms	0~10000	300	S

6.6.2.3 The corresponding table between IO input pin and running speed

The corresponding table between IO input pin and running speed is below.

CN2_19 (POS 3)	CN2_13 (POS 2)	CN2_10 (POS 1)	stage
OFF	OFF	OFF	external analog voltage control
OFF	OFF	ON	stage 1
OFF	ON	OFF	stage 2
OFF	ON	ON	stage 3
ON	OFF	OFF	stage 4
ON	OFF	ON	stage 5
ON	ON	OFF	stage 6
ON	ON	ON	stage 7

Notice:

- ON means that IO input pin being given low electrical level is effective. OFF means that IO input pin being given high electrical level suspends.
- To correctly set P1-44=10, P1-45=11, P1-46=12.

6.7 Torque Control

6.7.1. External analog voltage torque input (0~10V), external analog voltage speed input (0~10V)

6.7.1.1. Definition of wiring

CN2 PIN	Definition	Description
1	T_REF	external analog torque voltage
2	AGND	external analog voltage ground
3	V_REF	external analog speed voltage
4	TSPD+	torque reaching output signal
28, 38	0V	PLC power supply 0V
43	COM+	PLC power supply +24V

6.7.1.2. Parameter setting

necessary parameter	name	unit	parameter range	default value
P1-00	control mode		0~30	3
P1-04	internal servo start setting		0~1	0

P1-13	Max returning speed of analog speed instruction	Rpm	-6000~6000	3000
P1-15	limitation setting of speed and torque	%	0~500	100
P1-17	hardware zero-drift automatic adjust of analog speed/ torque		0~1	0
P1-18	hardware zero-drift manual adjust of analog speed		-4096~4096	0
P1-19	hardware zero-drift manual adjust of analog torque		-4096~4096	0
P1-23	voltage clamp of zero speed analog instruction		-6000~6000	20
P1-27	voltage clamp of zero torque analog instruction		-6000~6000	20
P1-50	torque reaching signal input electrical level		0000~1135	4
P4-43	the delay output time of torque reaching signal	0.1ms		10

6.7.2. Internal parameter torque setting, internal parameter speed given

6.7.2.1. Definition of wiring

CN2 PIN	Definition	Description
10	SC0	switch selection 0
13	SC1	switch selection 1
19	SC2	switch selection 2
28, 38	0V	PLC power supply 0V
43	COM+	PLC power supply +24V

6.7.2.2. Parameter setting

necessary parameter	name	unit	parameter range	default value
P1-00	control mode setting		0~30	3
P1-04	internal servo start setting		0~1	0
P1-44	digital IO access pin DI7 function plan		0000~1135	10
P1-45	digital IO access pin DI8 function plan		0000~1135	11

P1-46	digital IO access pin DI9 function plan		0000~1135	12
P1-50	hardware zero-drift automatic adjust of analog speed/ torque		0~1	4
P4-09	internal torque instruction 1 / internal torque limitation 1	‰	0~500	15
P4-43	the delay output time of torque reaching signal	0.1ms	-6000~6000	10
P4-44	Internal speed control given 1	Rpm	-6000~6000	100
P4-45	Internal speed control given 2	Rpm	-6000~6000	200
P4-46	Internal speed control given 3	Rpm	-6000~6000	300
P4-47	Internal speed control given 4	Rpm	-6000~6000	0
P4-48	Internal speed control given 5	Rpm	-6000~6000	-300
P4-49	Internal speed control given 6	Rpm	-6000~6000	-200
P4-50	Internal speed control given 7	Rpm	-6000~6000	-100

Notice: in this mode, among SC0, SC1 and SC2, there has at least one of them inputting effectively.

6.7.3.External analog voltage torque input (0~10V), internal parameter speed given

6.7.3.1.Definition of wiring

CN2 PIN	Definition	Description
1	T_REF	external analog torque voltage
2	AGND	external analog voltage ground
3	V_REF	external analog speed voltage
4	TSPD+	torque reaching output signal
10	SC0	switch selection 0
13	SC1	switch selection 1
19	SC2	switch selection 2
28, 38	0V	PLC power supply 0V
43	COM+	PLC power supply +24V

6.7.3.2.Parameter setting

necessary parameter	name	unit	parameter range	default value
P1-00	control mode setting		0~30	26
P1-04	internal servo start setting		0~1	0
P1-15	limitation setting of speed and torque	%	0~500	100
P1-17	hardware zero-drift automatic adjust of analog speed/ torque		0~1	0
P1-18	hardware zero-drift manual adjust of analog speed		-4096~4096	0
P1-19	hardware zero-drift manual adjust of analog torque		-4096~4096	0
P1-27	voltage clamp of zero torque analog instruction		-6000~6000	20
P1-44	digital IO access pin DI7 function plan		0000~1135	10
P1-45	digital IO access pin DI8 function plan		0000~1135	11
P1-46	digital IO access pin DI9 function plan		0000~1135	12
P1-50	hardware zero-drift automatic adjust of analog speed/ torque		0~1	4
P4-09	internal torque instruction 1 / internal torque limitation 1	‰	0~500	15
P4-43	the delay output time of torque reaching signal	0.1ms	-6000~6000	10
P4-44	Internal speed control given 1	Rpm	-6000~6000	100
P4-45	Internal speed control given 2	Rpm	-6000~6000	200
P4-46	Internal speed control given 3	Rpm	-6000~6000	300
P4-47	Internal speed control given 4	Rpm	-6000~6000	0
P4-48	Internal speed control given 5	Rpm	-6000~6000	-300
P4-49	Internal speed control given 6	Rpm	-6000~6000	-200
P4-50	Internal speed control given 7	Rpm	-6000~6000	-100

Notice:

● When SC0=OFF, SC1=OFF, SC2=OFF, servo motor be in state of zero speed, in this case, the limitation value of torque is set according to P4-09.

- When the signal of any one or more than one among SC0, SC1 and SC2 is ON, servo motor speed is selected from servo internal parameter setting according to external I/O selection signal, the limitation value of torque is given by the external analog voltage.

6.8 Adjustment

6.8.1 Basic gain adjustment

Notice:

- Wrong parameter setting may lead to devices failures and accidents. Before starting, please confirm that the parameters are correct.
- Suggest to do load-free debugging firstly, then load debugging.

6.8.1.1. Speed control

- ◆ For [speed ratio gain] (parameter P2-00), under the condition of no oscillation, the value should be set high as possible. Generally, the more load inertia is, the higher the set value is.
- ◆ For [velocity integral time constant] (parameter P2-01), according to the given condition, the value should be set low as possible. The lower the value is, the quicker the response speed is. But it easily lead to oscillate. Under the condition of no oscillation, to set small value as possible. If the value is too high, when the load changes, the speed will change much.

6.8.1.1. Position control

- ◆ Firstly To set suitable speed ratio gain and velocity integral time constant according to the above ways.
- ◆ [position feed-forward gain](parameter P2-04) should be set as 0%.
- ◆ For [position ratio gain](parameter P2-02), in the range of stability, the value should be set high as possible. The higher the value is, the better the tracking characteristics of position instruction is, log error becomes small. But when stop for positioning, easily lead to oscillation.
- ◆ If demanding much better position tracking characteristics, can increase set values of [position feed-forward gain]. However if increased too much, will lead to over adjustment.

Notice:

When the value of position ratio gain is set low, the system will be stable. But the position tracking characteristics will be weaken, and lag error becomes much.

6.8.2 Basic parameter adjustment diagram

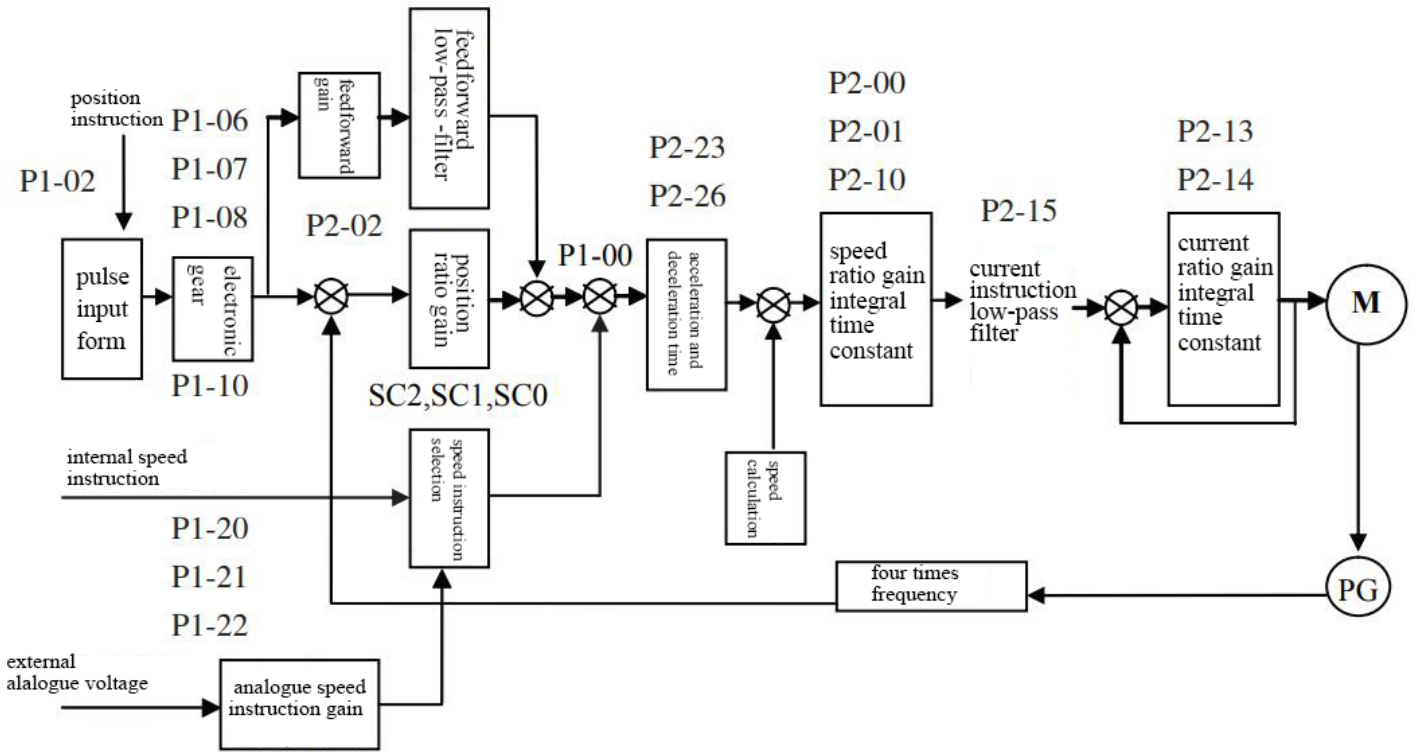

6.8.3 Position resolution and electronic gear setting

Position resolution (one pulse stroke ΔI) is decided by servo motor one circle stroke ΔS and encoder one circle feedback pulse P_t . which can be shown as the following equation:

$$\Delta I = \frac{S}{P}$$

in the equation, ΔI : one pulse stroke (mm); ΔS : servo motor stroke each round (mm/r); P_t : encoder feedback pulse number each round (p / r). Servo motor incremental encoder is 2500 lines resolution, so $P_t=10000$ p/r. position control pulse equals to instruction pulse multiplies electronic gear ratio.

An instruction pulse must be multiplied by an electronic gear g before turning A position control pulse

Chapter7 Alarm and Coping with

Notices:

- The people involved in the maintenance must have the corresponding professional knowledge and ability.
- Before touching the driver and motor, the power supply for servo drive unit and motor must be cut off at least for 5 minutes, so as to avoid electric shock and burn.
- After the driver unit failures alarming, before putting them into use again, need to deal with the failures according to the alarm code.
- Before reset alarm, must confirm SON (servo be effective) signal invalid, to avoid motor run suddenly to cause accidents.

7.1 List of Alarm

Alarm symbol	Alarm name	Content
--	normal	
ALE01	over-speed	servo motor speed over the setting value
ALE02	main circuit over-voltage	voltage of main circuit power supply is too high
ALE03	main circuit under-voltage	voltage of main circuit power supply is too low
ALE04	Position over-error value	the value of position deviation counter is higher than the set value
ALE05	Motor overheating	the temperature of motor is too high
ALE06	Saturation fault of speed amplifier	the speed amplifier saturates in long time
ALE07	Driver prohibition be abnormal	CCW,CW drive prohibiting input both in the state of "OFF"
ALE08	position deviation counter spill	the absolute value of position deviation counter over 2^{30}
ALE09	encoder feedback signal fault	feedback data or signal of encoder is wrong
ALE10	control power supply under-voltage	the voltage of control power supply is lower
ALE11	IPM module fault	IPM intelligent module fault
ALE12	over-current	the current passing the motor is too high
ALE13	over-load	the load is over the allowed Max load of servo driver and motor (instantaneous over-heat)
ALE14	brake failure	brake circuit failure

ALE15	motor pole pairs fault alarm	the pole pairs number aren't suitable for the correspondent motor
ALE16	main circuit cut-off alarm	main circuit not be electrified
ALE17	retaining	retaining
ALE18	motor type invalid	motor type not be written inside incremental encoder EEPROM
ALE19	encoder wire cut-off alarm	encoder wire no connecting or cut off
ALE20	EEPROM wrong	EEPROM wrong
ALE21	series ports communication error alarm	RS232 or RS485 communication error
ALE22	current samples circuit alarm	the current sample power supply input is incorrect

7.2 Ways to Cope with Alarms

alarm code	alarm name	running states	reason	Methods
ALE01	over-speed	to occur when connecting control power supply	① control circuit failure ② encoder failure	①change servo driver ②change servo motor
		to occur during the process of motor running	input instruction pulse frequency too high	correctly set input instruction pulse
			the time constant of acceleration / deceleration too small, to make speed over-adjusting-amount too large	to increase the time constant of acceleration / deceleration
			input electronic gear ratio too large	correctly set the ratio
			encoder failure	change servo motor
			encoder cable is damaged	change encoder cable
			servo system unsteadily, to arise over-adjusting	①reset the related gain ②if gain can't set up to suitable value, to reduce the load rotary inertia rate
		to occur when the motor just starts	load inertia too high	①reduce load inertia ②change the big power driver and motor

			encoder zero-point fault	①change servo motor ②ask for the factory to reset the encoder zero-point
			①wrong lead wire connecting of motor terminals U, V, W ②wrong lead wire connecting of encoder cable	correctly connecting
ALE02	main circuit over- voltage	to occur when connecting control power supply	circuit board failure	change servo drive unit
		to occur when connecting main power supply	①voltage of power supply to high ②voltage wave form of power supply be abnormal	check the power supply
		to occur during the process of motor running	brake resistance connecting wire be shut off	connect the wire again
			①brake transistor be damaged ②internal brake resistance be damaged	change servo drive unit
			capacity of brake return-circuit not enough	①reduce the switch frequency ②raise acceleration / deceleration time constant ③decrease the torque limitation value ④reduce load inertia ⑤ change big power driver and motor
ALE03	main circuit under- voltage	to occur when connecting main power supply	①circuit board failure ② power supply fuse be damaged ③soft-start circuit failure ④rectifier be damaged	change servo drive unit
			①power supply under-voltage ②power be cut off temporarily over 20ms	check the power supply
			electrify frequently	the interval between power on and on is more than 3 seconds.
		to occur during the process of motor running	①power supply capacity not enough ②instant power-down ③IPM module short circuit	check the power supply and IPM module
			radiator overheating	check the load
ALE04	position over-error value	to occur when connecting control power supply	circuit board failure	change servo driver

		to connect main power supply and control wire, input instruction pulse, motor don't rotate	①the lead wire of motor terminals U, V, W connecting wrong ②the lead wire of encoder cable connecting wrong	connect correctly
			encoder failure	change servo motor
			position over-error detecting range be set to too small	increase the position over-error testing range
			position proportion gain too small	increase gain
			torque not enough	①check torque limitation value ②reduce load ③change big power drive unit and motor
			instruction pulse frequency too high	reduce frequency
ALE05	motor overheating	to occur when connecting control power supply	circuit board failure	change servo drive unit
			①cable cut off ②temperature relay inside the motor be damaged	①check cable ②check motor
		to occur during the process of motor running	motor over load	①reduce load ②reduce switch frequency ③reduce torque limitation value ④reduce related gain ⑤change big power drive unit and motor
			motor internal failure	change motor
ALE06	Saturation fault of speed amplifier	to occur during the process of motor running	motor be jammed by machinery	check load from machinery part
			load too large	①check load ②change big power drive unit and motor
ALE07	Driver prohibition be abnormal		CCW,CW drive prohibition terminals all be cut off	check wiring, power supply for input terminals
ALE08	position deviation counter spill		① motor be jammed by machinery ②input instruction pulse abnormally	①check load from machinery part ②check instruction pulse ③ check motor whether rotates according to its receiving instruction pulse
			encoder wiring wrong	check wiring
			encoder be damaged	change motor

ALE09	encoder feedback signal fault	to occur during the process of motor running	encoder cable is damaged	change cable
			encoder cable is too long, to cause power supply voltage of encoder be little low	①shorten cable ②adopt multi-core parallel power supply
ALE10	control power supply under-voltage		the voltage of input control power supply is low	check control power supply
			①driver inner connector be abnormal ②switch power be abnormal ③ chips be damaged	①alter drive unit ②check connector ③ check switch power supply
ALE11	IPM module fault	to occur when connecting control power supply	circuit board failure	alter servo drive unit
		to occur during the process of motor running	①voltage of power supply be little low ②over-heat	①check drive unit ②electrify again ③ alter drive unit
			short circuit among driver terminals U, V, W	check wiring
			grounding abnormally	grounding correctly
			motor insulation be damaged	alter motor
			be interfered	①add circuit filter ②electrify again ③ avoid interference
ALE12	over-current		short circuit among driver terminals U, V, W	check wiring
			grounding abnormally	grounding correctly
			motor insulation be damaged	alter motor
			driver be damaged	alter drive unit
ALE13	over-load	to occur when connecting control power supply	circuit board failure	alter servo drive unit
		to occur during the process of motor running	exceed rated torque to run	①check load ②reduce switch frequency ③reduce torque limitation value ④alter big power drive unit and motor
			holding brake doesn't open	check holding brake
			motor running unsteadily and vibrating	①increase gain ②increase acceleration / deceleration time ③reduce load inertia
			① the wiring of one phase among terminals U,V,W be cut off	check wiring

			②encoder connecting wrong	
ALE14	brake failure	to occur when connecting control power supply	circuit board failure	alter servo drive unit
		to occur during the process of motor running	the connecting of brake resistance be cut off	connect the wire again
			① brake transistor be damaged ②internal brake resistance be damaged	alter servo drive unit
			capacity of brake return-circuit not enough	①reduce the switch frequency ②raise acceleration / deceleration time constant ③decrease the torque limitation value ④reduce load inertia ⑤ alter big power driver and motor
			voltage of main circuit power supply too high	check main power supply
ALE15	motor pole pairs fault alarm	to occur during the process of motor electrifying or running	motor pole pairs aren't matched with the correspondent motor	modify the correct pole pairs of the correspondent motor, then re-electrify again
ALE16	main circuit cut-off alarm		main return-circuit no power	check main power supply
			main return-circuit over-voltage	check main power supply
			main return-circuit under-voltage	check main power supply
ALE18	motor type invalid		motor type not be written inside incremental encoder EEPROM	write motor type into incremental encoder when the motor out from factory
ALE19	encoder wire cut-off alarm		encoder wire no connecting or be damaged	connect the encoder cable, or alter encoder cable
ALE20	EEPROM wrong		chips or circuit board be damaged	①alter servo driver unit ②after restoring them, must reset driver type (parameters P1-01), then restore default parameters
ALE21	series ports communication error alarm		RS232 or RS485 communication error	①check whether the communication wire is good ②whether communication data form is correct.

ALE22	current samples circuit alarm		the current sample power supply input is incorrect	①check whether the current of power supply is within the rated range ②check whether amplifying circuit link be abnormal.
-------	-------------------------------	--	--	---

Chapter 8 Communications

8.1 Suitable for the Extent

DSL200 series driver support MODBUS RTU protocol, can use RS-232 or RS485 communication (can't be used simultaneously), can carry out "one PLC for several drivers" communication network. Before utilizing communication function, each driver must set communication parameters (station No. : P3-00, baud rate: P3-1, data format: P3-02) well. By communication function of master computer, can directly modify driver internal parameters, read servo running states etc.

8.2 Protocol Format

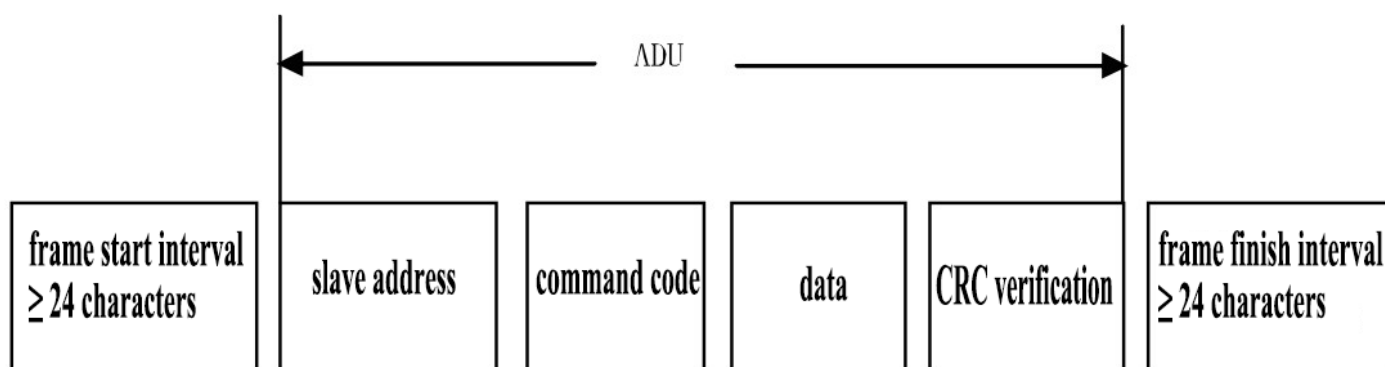

The protocol format is shown as the above diagram, verification in ADU is the front part of CRC16 verification, and is obtained by the delivery among high-low characters. In protocol format, the low bytes of CRC are in the front, the high bytes are in the rear.

8.2.1 Read servo drive function code parameters or states bytes (command code : 0×03)

ADU part content	bytes	range
Host send request		
slave machine address	1	1-0×FEH
command code	1	0×03H
register start address	2	0×0000H-0×FFFFH
register numbers	2	0×0000H-0×0008H
CRC verification (the low bytes are in the front)	2	
slave machine response		
slave address	1	local address
command code	1	0×03H

read bytes numbers	1	0×02H
register content	2	register content
CRC verification	2	

For example: read parameter P1-06=1

Host station send: 0×01 0×03 0×01 0×06 0×00 0×01 0×65 0×f7

Slave station response: 0×01 0×03 0×02 0×00 0×01 0×79 0×84

8.2.2 Write servo drive single function code or control parameters (command code : 0×06)

ADU part content	bytes	range
Host send request		
slave machine address	1	1-0×FEH
command code	1	0×06H
register start address	2	0×0000H-0×FFFFH
data content	2	0×0000H-0×0008H
CRC verification (the low bytes are in the front)	2	
slave machine response		
slave address	1	local address
command code	1	0×03H
register address	2	0×0000H-0×FFFFH
register content	2	register content
CRC verification	2	

For example: to write 10 into the parameter P1-06

Host station send: 0×01 0×06 0×01 0×05 0×00 0×0A 0×36 0×C2

Slave station response: 0×01 0×06 0×01 0×05 0×00 0×0A 0×69 0×FB

8.2.3 Write servo drive single function code or control parameters (command code : 0×10)

ADU part content	bytes	range
Host send request		
slave machine address	1	1-0×FEH
command code	1	0×10H
register start address	2	0×0000H-0×FFFFH
register content bytes number	1	0×0000-0×0008
register content	2*register number	
CRC verification (the low bytes are in the front)	2	

slave machine response		
slave address	1	local address
command code	1	0×10
register address	2	0×0000-0×FFFF
ADU part content	bytes	range
register number	2	0×0000-0×0008
CRC verification	2	

8.3 CRC Verification

For sender, calculate CRC values firstly, and attach its in the sending messages. After receiving the messages, the receiver will re-calculate CRC values again, then compare the recalculated values with the received CRC values. If they aren't equal, it means that there are something wrong during the process of sending.

The calculating process of CRCj verification:

- (1) To define one CRC register, and assign an initial value, 0×FFFF
- (2) To make XOR calculation between the first byte of sent messages and the values of CRC register, and put the calculation result into CRC register, begin from the address code, the calculation excludes start bit and stop bit.
- (3) To abstract and check LSB (the lowest bit of CRC register)
- (4) Each bit of CRC register moves one bit to the right, and the highest bit is supplemented by "0".
- (5) If LSB is 1, to make XOR calculation between the values of register and A001H, and put the result into CRC register.
- (6) To repeat the procedure (3),(4),(5), till finishing 8 times move.
- (7) To repeat the procedure(2),(3),(4),(5),(6), deal with the next byte of sent information. Continue to repeat the above procedure, till finishing all the works to deal with all bytes of information sending.
- (8) Calculation finished, the content of CRC register is the CRC verification vales
- (9) When sending, firstly send low bytes of CRC verification values, then send high bytes.