

ECR60/ECT60

User manual



Shenzhen Rtelligent Mechanical Electrical Technology Co., Ltd.

— Drive description

1.1 Product introduction

Thank you for choosing the Rtelligentr EC series stepper motor driver. The EC Series is a high-performance bus-controlled stepper motor driver with the ability to integrate intelligent motion controllers. The EC Series EtherCAT drives can be operated as standard EtherCAT slaves and support CoE (CANopen over EtherCAT).

The ECR60 is open-loop control and the ECT60 is closed-loop control.

1.1.1 Characteristics

- Operating voltage DC: 24 to 80V
- Support for CoE (CANopen over EtherCAT), CiA 402 compliant
- Support for CSP, PP, PV, Homing mode
- Minimum sync period 500us
- Double-mouthEd RJ45 connector for EtherCAT communications
- Maximum phase current output: 6A/phase (sine peak)
- Control methods: open-loop control, closed-loop control, FOC control
- Digital IO port:

6-way photoelectric isolation of digital signal input: IN1,IN2 for 5V differential input, can also be connected to 5V single-ended input, IN3toIN6 for 24Vsingle-ended input, total anode method;

2-way photoelectric isolation of digital signal output, maximum resistance voltage of

30V, maximum infusion or pull-out current 100mA, common cathode docking method.

1.1.2 Electrical characteristics

ECR60 Electrical characteristics

Product model	ECR60	ECT60
Output current	0.5 to 6A	
Supply voltage	24 to 80VDC	
Matching motors	Below 86 base	
Encoder interface	No	Incremental orthogonal encoder, 4x
Encoder resolution	No	1000 to 65535 pulses/revolution
Photoelectric isolation input	6 way : 2 way 5V differential input, 4 road common anode 24V input	4-way common anode 24V input
Photoelectric isolation output	2-way photoelectric isolation output: alarm, lock, in place and universal output	
Communication interface	RJ45	

Do not exceed the scope of use described above.

1.2 Power and motor

Identity	Description
V-plus	DC-powered, positive, V-connected power supply negative. The voltage is 24 to 80VDC. Due to the effect of the anti-electric potential, the customer needs to reserve a certain amount of voltage margin when using
V-	
A-plus	Two-phase stepper motor winding interface Any pair of A-plus, A--
A-	
B-plus	
B-	

1.2.1 Connecting the power supply

Connection driver and DC power supply: Positive, V-DC power negative

Ensure a reliable connection between the drive base and the earth with a ground screw
ECR60 power range of 24 to 80VDC, pay attention to the positive and negative polarity of the power supply

1.2.2 Connecting the motor

If you are using a rite-hit stepper motor, connect the black, green, blue, and red four wires in turn to the a-plus, A-, B-, B-ports of the drive.

1.2.3 Connection encoder

This feature is limited to ECT60 products. The ECT60 is fixed using IN1plus/IN1-andIN2plus/IN2- as the encoder input interface.

The connection of the particular encoder needs to be based on the motor manufacturer's instructions.

1.3 Digital input and output ports

The ECR60 stepper driver has 6 photoelectric isolated digital inputs and 2 photoelectric isolated digital ports.

ECT60 Because IN1 and IN2 are assigned to orthogonal encoder interfaces, they can no longer be used for other input port functions and will not work for IN1, IN2 functional settings.

1.3.1 Digital input port

The ECR60 step driver has 6 digital inputs and 2 digital outputs. The object dictionary [0x2007](#) is the functional setting for the input port, and [0x2008](#) is the polarity setting for the input port.

Note: IN1s/IN1-, IN2s/IN2- is a 5V input terminal, do not directly connect the input signal above this voltage, as this will cause damage to the driver!

The schematic of the input port is shown below, and the user can wire the system according to the schematic.

Driver

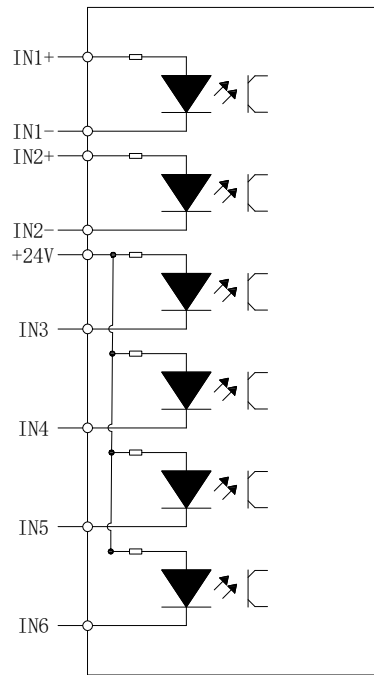

IN1plus/IN1-, IN2 plus /IN2- differential input terminals

IN1,IN2 is reserved external motor encoder, constitutes a closed-loop system, ECR60 can not receive encoder signal. ECT60 is only allowed.

5V differential input

Servo Driver

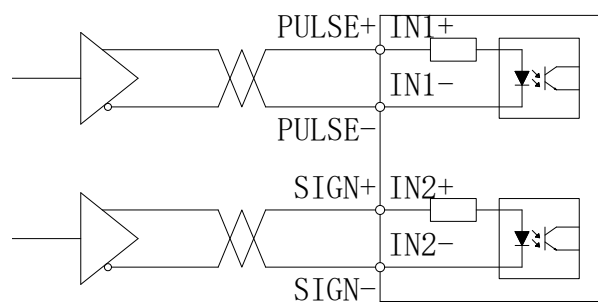

5V single-ended input

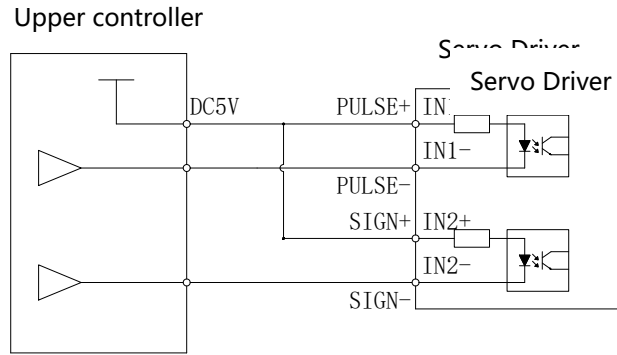

Note: When the IN1 and IN2 ports use the 24V input, please string the 2K limiting resistance externally, otherwise the drive will be damaged.

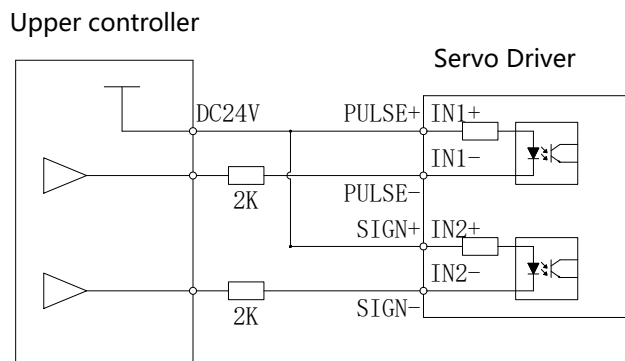

IN3to IN6 single-ended input terminals

Taking IN3 as an example, the IN3toIN6 interface circuits are the same.

When the upper unit is the relay output:

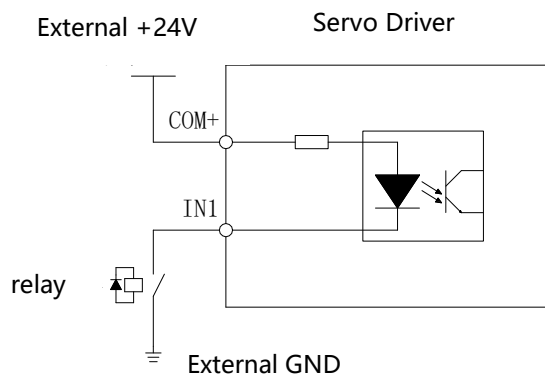

When the upper unit is an open output for the collector:

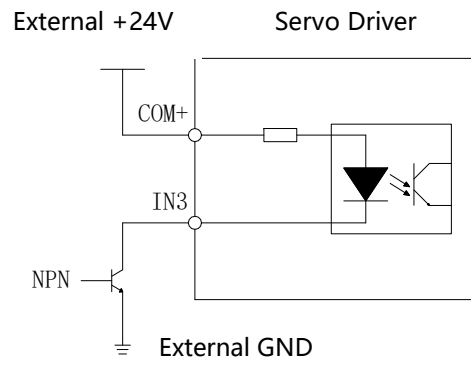

Note: PNP input is not supported

1.3.2 Digital output port

The ECR60/ECT60 contains two photoelectric isolation output signals.

OUT1 has an output current capacity of 30mA.

OUT2 has an output current capacity of 150mA.

The digital output port is all normally open by default, the function of the output port can be selected by object dictionary 2005, and the object dictionary 2006 is used to set the polarity of the set output port.

Object dictionary	Name	Property	Type	Range	The default value	Unit	Note
0x2005:01	Output Port 1 Function	R/W/S	UINT	0 to 3	1	---	Output port feature selection: 0 - Custom output 1 - Alarm output 2 - Holding gate output 3 - Output in place
0x2005:02	Output port 2 function	R/W/S	UINT	0 to 3	2	---	
0x2006	Output port polarity settings	R/W/S	UINT	0 to 3	3	---	Set the normally open, normally closed feature of the output port 0 - Often closed 1 - Always open

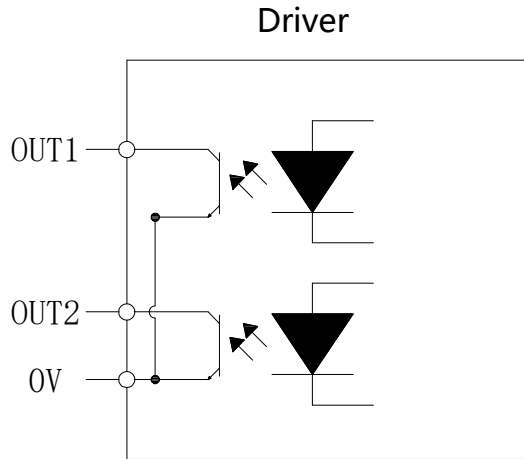

Take OUT1 as an example, the OUT1 to OUT2 interface circuit is the same.

When the upper unit is entered for a relay:

Correct wiring diagram:

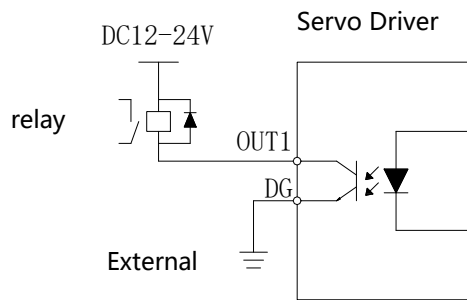

Error wiring diagram:

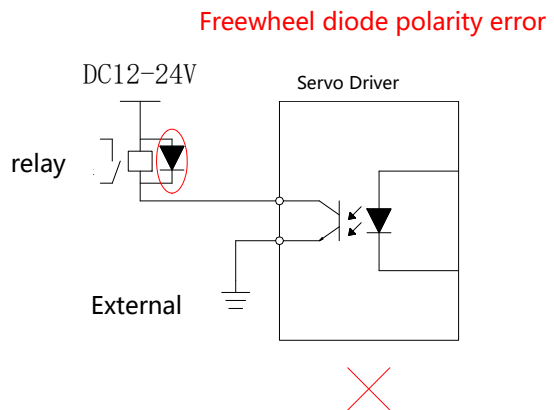
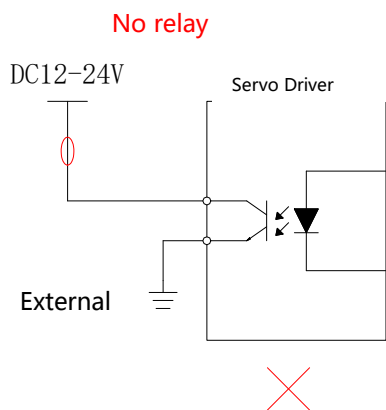

When the upper unit is optically coupled input:

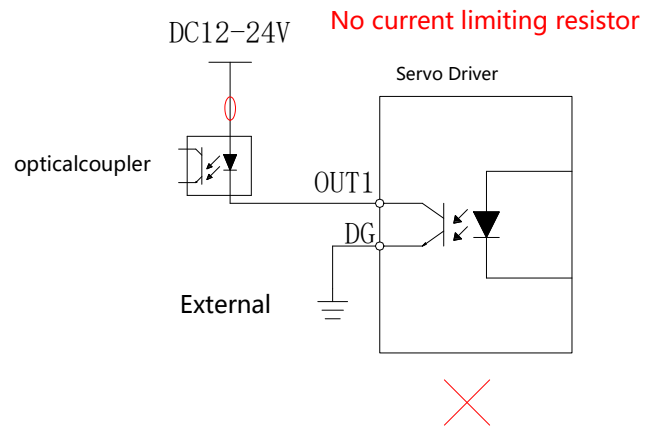
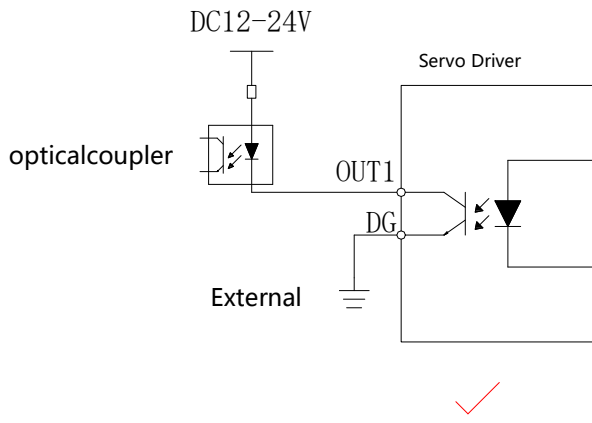

1.4 Connect etherCAT

Use cat5E (or higher) network cables.

The Ethernet input inn IN is connected to the Ethernet output interface OUT of the controller or the previous driver on the bus. The Ethernet output interface OUT is connected to the Ethernet input inthe for the next driver on the bus. If the drive is the last node on the bus, only the Ethernet input IN needs to be connected.

1.4.1 EtherCAT status indicator

The yellow light of RJ45 is used in the Link state to indicate whether there is a network connection.

The green light for RJ45 is used for the Activity status, indicating whether there is data communication.

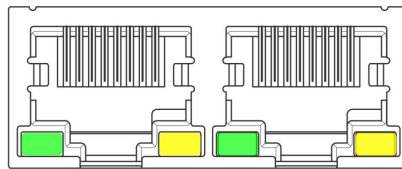

RUN/ERR LED:

Led	Color	State	Describe
RUN	Green	Not on	initialization state
		Slow flash	pre-operational state
		Single flash	safe-operational state
		Always bright	operational state
Err	Red	Not on	No errors
		Slow flash	General errors
		Single flash	Sync error
		Double Flash	Watchdog mistake

Flash: 50ms, 50ms (10Hz). So loop.

Slow flash: 200ms, 200ms (2.5Hz). So loop.

Single flash: 200ms, 1s. So loop.

Double flash: bright 200ms, 200ms, 200ms, 1s. So loop.







1.5 EtherCAT site address

The EC series supports two ways to set the slave address: the object dictionary 0x2150 set the site alias and the ESC set site alias, and selected by the object dictionary 0x2151. The default 0x2151 is 0, and the node address is allocated through the master and saved to EEPROM.

When the user needs to set a fixed address on their own, they need to set 0x2151 to 1 and then write the desired address value in 0x2150.

0x2151	0x2150	Site address
0	1001	Master configuration site alias to ESC EEPROM 0x0004 word address
1	Set a value	Object dictionary 2150 set value is node address value

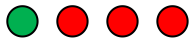
1.6 Alarm code

LED status		Drive status
	The green light is on.	Drive does not enable
	Flashing green light	Drive works
	1 green, 1 red	Drive Overcurrent
	1 green, 2 red	Drive input power overvoltage
	1 green, 3 red	There was an error in the voltage inside the driver
	1 green, 4 red	Encoder variance alarm
	1 green, 6 red	Parameter check error

1.7 Mechanical size

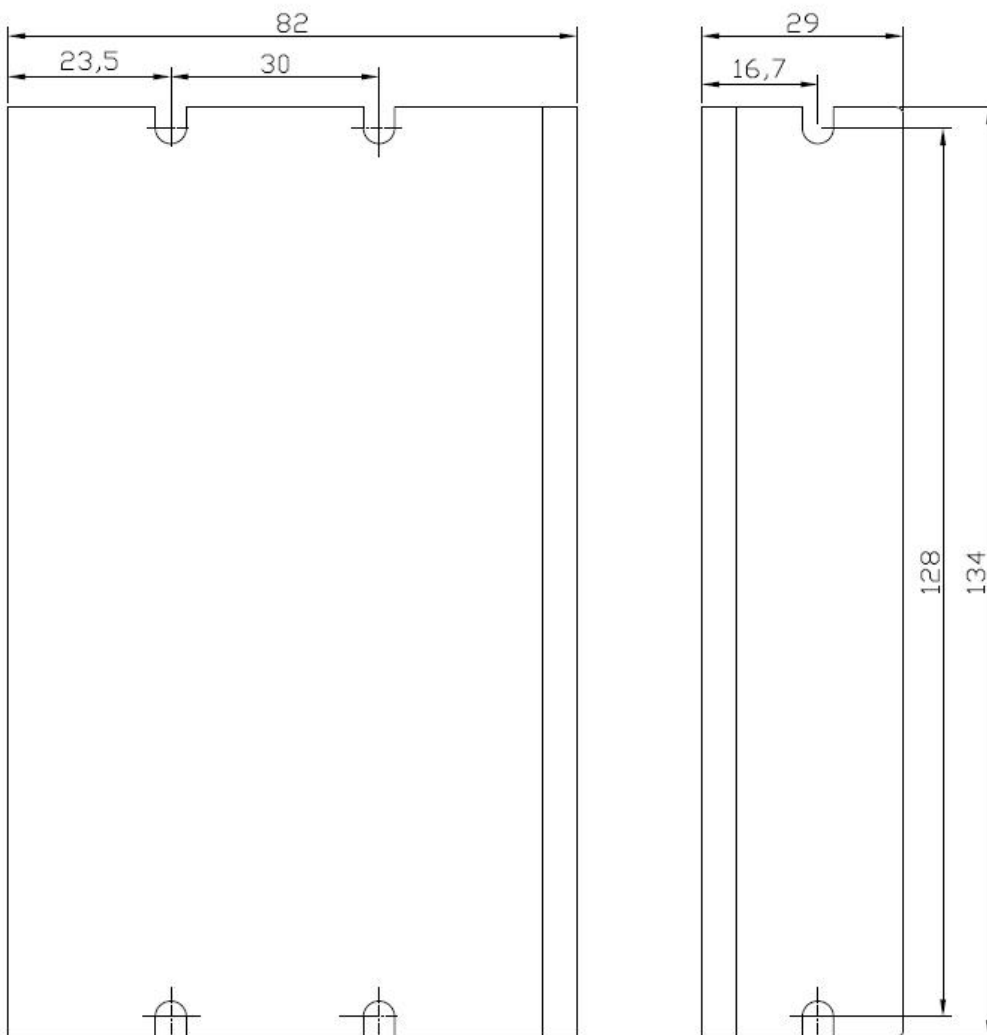

二 Parameter description and settings

2.1 General use parameter

2.1.1 0x1000 Unit Type

Object Type	Data Type	Access Type	PDO Mapping	Default Value
Var	UNSIGNED	Ro	NO	0x00040192

Bit 0-15: Device profile number 0x0192: CiA402

Bit 16-31: Additional information 0x0004: Stepper Drive

2.1.2 0x1001 Appliance Name

Displays the current drive model name.

The ECR60-42 function, like the ECR60, only limits the default current of the driver, preventing the user from matching the small motor, without the first time to modify the current of the driver resulting in excessive current, damage to the driver and the motor.

On 0x1001, both show "ECR60"

Object Type	Data Type	Access Type	PDO Mapping	Default Value
Var	Visible string	Ro	NO	ECR60

ECT60

Object Type	Data Type	Access Type	PDO Mapping	Default Value
Var	Visible string	Ro	NO	ECT60

2.1.3 0x1009 Hardware Version

Object Type	Data Type	Access Type	PDO Mapping	Default Value
Var	Visible string	Ro	NO	0xA1

2.1.4 0x100A Software Version

Object Type	Data Type	Access Type	PDO Mapping	Default Value
Var	Visible string	Ro	NO	0x101A

2.1.5 Save parameters

Sub-index of object dictionary 0x1010: 01 writes 1, which saves the current parameter.

When saving the parameters, stop the motor first, and then save the parameters.

The data structure is as follows:

Index	Sub-index	Name	PDO mapping	The default value
1010	00	Maximum number of sub-indexes	No	1
	01	Save parameters	No	0

2.1.6 Restore factory settings

Sub-index of object dictionary 0x1011: 01 writes to 1, then powers on again to restore the drive to factory state.

When factory settings are restored, stop the motor first, and then save the parameters.

Index	Sub-index	Name	PDO mapping	The default value
1011	00	Maximum number of sub-indexes	No	1
	01	Save parameters	No	0

2.2 Manufacturer-specific objects

2.2.1 0x2000 operating current

Object dictionary	Name	Property	Type	Range	The default value	Unit
0x2000	Peak Current	R/W/S	UINT	100 to 6000	3000	mA

The object is used to set the sine peak current for the run of the stepper motor opening.

2.2.2 0x2001 segmentation/resolution

Object dictionary	Name	Property	Type	Range	The default value	Unit
0x2001	Motor Resolution	R/W/S	UINT	200 to 65535	10000	Pulse/rev

This object is used to set the number of pulses required for the motor to run a circle while the stepper motor is running.

The ECT60 operates in closed-loop mode by default, where the number of pulses required for the motor to run a circle is set by the [0x2020 encoder](#) resolution.

2.2.3 0x2002 Standby Time

Object dictionary	Name	Property	Type	Range	The default value	Unit
0x2002	Idle Time	R/W/S	UINT	200 to 65535	500	Ms

This object is used to set the time when the stepper motor is in standby when it stops running.

2.2.4 0x2003 Standby Current Percentage

Object dictionary	Name	Property	Type	Range	The default value	Unit
-------------------	------	----------	------	-------	-------------------	------

y						
0x2003	Idle Current Percent	R/W/S	UINT	0to100	50	%

This object is used to set the percentage of the operating current set by 0x2000 when the motor stops running into standby when the motor is in standby while running on the ring of the stepper motor.

2.2.5 0x2005 output port function

Object dictionary	Name	Property	Type	Range	The default value	Unit
0x2005:01	Output 1 Function	R/W/S	UINT	0 to 3	1	---
0x2005:02	Output 2 Function	R/W/S	UINT	0 to 3	2	---

The ECR60 contains two output ports, which are used to set the corresponding function of the output port.

The port functionality is defined as follows:

Value	Function
0	Custom output
1	Alarm output
2	Holding gate output
3	Output in place

When set to custom output, the state of the port can be controlled by the polarity setting of [0x2006](#).

2.2.6 0x2006 output port polarity

Object dictionary	Name	Property	Type	Range	The default value	Unit
0x2006	Outputs Polarity	R/W/S	UINT	0to3	3	---

Set the normally open and normally closed characteristics of the output port: Bit0 is the output port 1 polarity setting, bit1 is the output port 2 polarity setting.

0 - Often closed

1 - Always open

Bit15 to bit2	Bit1	Bit0
---	OUT2	OUT1

2.2.7 0x2007 Input Port Function

Object dictionary	Name	Property	Type	Range	The default value	Unit
0x2007:01	Input 1 Function	R/W/S	UINT	0 to8	0	---
0x2007:02	Input 2 Function	R/W/S	UINT	0 to8	0	---
0x2007:03	Input 3 Function	R/W/S	UINT	0 to8	1	---
0x2007:04	Input 4 Function	R/W/S	UINT	0 to8	2	---
0x2007:05	Input 5 Function	R/W/S	UINT	0 to8	3	---
0x2007:06	Input 6Function	R/W/S	UINT	0 to8	6	---

The ECR60 contains six input ports, which are used to set the corresponding functions for the input port.

Value	Function
0	Universal input
1	CW Limit Input
2	CCW Limit Input
3	HOME input
4	Clear the fault
5	Emergency stop signal
6	Motor offline
7	Probe 1
8	Probe 2

The state of the input port can be read by the [0x60FD](#) object.

The polarity of the input port can be set by the [0x2008](#) object.

2.2.8 0x2008 Input Port Polarity

Object dictionary	Name	Property	Type	Range	The default value	Unit
0x2008	Inputs Polarity	R/W/S	UINT	0to3F	0x3F	---

Each bit defines the polarity of the corresponding port. Bit 0 defines the polarity of input

1:

Bit15 to bit6	Bit5	Bit4	Bit3	Bit2	Bit1	Bit0
---	IN6	IN5	IN4	IN3	IN2	IN1

0 - Often closed,1 - Always open

2.2.9 0x2009 filter time

Object dictionary	Name	Property	Type	Range	The default value	Unit
0x2009	Filter Time	R/W/S	UINT	0to25600	6400	us

The ECR60 has a sliding average filter built in, which is used to set the time of the sliding average filter. The greater the filtering time, the more smooth the motor starts and stops, but the greater the response lag of the motor.

Latency - Filter Time

2.2.10 0x200A lock shaft time

Object dictionary	Name	Property	Type	Range	The default value	Unit
0x2009	Soft lock Time	R/W/S	UINT	0to65535	1000	50us

The ECR60 requires locking the stepper motor for initial positioning when enabling, and in order to reduce the jitter of the initial positioning, the ECR60 has built-in ramp locking shaft function. This object is used to set the ramp time of the motor lock shaft when the motor is enabling.

Lock shaft time s set value x 50us x 2 s set value x 100us

2.2.11 0x200B current ring parameters

Object dictionary	Name	Property	Type	Range	The default value	Note
0x200B:01	AutoPI enable	R/W/S	UINT	0 to 1	1	Identify motor parameters while the driver is initially positioned and automatically calculate the PI gain 0-- No enable; 1-- enable

0x200B:02	Iloop_Kp	R/W/S	UINT	100 to 100 to 65535	1000	This register cannot be set when 0x200B:01 is 1. At 0, you can set it
0x200B:03	Iloop_Ki	R/W/S	UINT	0 to 0 10000	200	
0x200B:04	Iloop_Kc	R/W/S	UINT	0 to 1024	256	Anti-integration saturation coefficient.

The ECR60 uses current control to subdivide the stepper motor. The ECR60 uses the automatic recognition parameter algorithm by default to identify the electrical parameters of the motor and automatically calculate the appropriate current ring PI parameters. When the automatically recognized PI parameters do not meet the requirements, the user can set the parameters themselves.

2.2.12 0x200C motor parameters

Object dictionary	Name	Property	Type	Range	The default value	Note
0x200C:01	Motor type	R/W/S	UINT	0 to 1	0	0 - two-phase stepper motor 1 - three-phase stepper motor, reserved function, current version is not available
0x200C:02	Resistance Auto	R	UINT	100 to 100 to 65535	1000	When the automatic PI is turned on, the motor winding resistance value is recognized. Unit:mOhm
0x200C:03	InductAuto	R	UINT	0 to 0 10	1	When the automatic PI is turned on, the motor winding inductor value is recognized.

						Units:mH
0x200C:04	Resistance Set	R/W/S	UINT	0 to 0 10000	1000	Motor winding resistance value Unit:mOhm
0x200C:05	Ingrace Set	R/W/S	UINT	1 to 10	1	Motor winding inductor value Units:mH
0x200C:06	BEMF coefficientMF	R/W/S	UINT	0 to 1000	256	ECT60

Open ring and servo mode1:

The ECR60 open-loop control stepper motor and The ECT60 operate in servo mode 1 when the motor parameters themselves do not participate in the motor control, the user does not need to be specially set. The user can determine whether the connection of the motor is normal by checking the self-identification resistance and inductor value of the object.

Servo mode 2:

The ECT60 operates in servo mode 2 and the closed-loop stepper motor is in FOC mode. Due to the special structure of the stepper motor, weak magnetic control is required in order to carry out foc control. The weak magnetic control parameters are estimated by the resistance, inductor and anti-electric coefficient of the motor.

Usually the automatically estimated resistance and inductor can meet the demand, the user can also set the resistance to the inductor according to the motor manufacturer's motor parameters. The calculation of the anti-electric potential coefficient can be calculated using the following formula:

$$0x200C:06 \text{ s}(\text{Rated Torque (N.M)}/\text{Rated Current (A)}) \times 500$$

2.2.13 0x200D Run Reverse

Object dictionary	Name	Property	Type	Range	The default value	Unit
0x200D	Invert motor direction	R/W/S	UINT	0to1	0	---

If the positive direction of the motor is not consistent with the system requirements, the object can reverse the direction of operation of the motor without modifying the motor wiring.

2.2.14 0x200E internal alarm code

Object dictionary	Name	Property	Type	The default value
0x200E	Alarm Code	R	UINT	0

This object shows the current fault code for the drive, with each bit of the object corresponding to an alarm state.

Alarm code	Alarm status
0x0001	Internal voltage error
0x0002	Overcurrent
0x0004	Overpressure
0x0008	Keep
0x0080	Position error is excessive
Other	Keep

When the above failure occurs, the fault codes of 0x603F and 0x200E are cleared by writing 0x6040 to the 0x6040 object after the failure condition is eliminated.

2.2.15 0x200F internal status code

Object dictionary	Name	Property	Type	The default value
0x200F	Status Code	R	UINT	0

This object shows the current state code of the drive, with each bit of the object corresponding to a state.

Status Code	State
0x0001	Drive enable
0x0002	Drive failure
0x0004	Signal in place, reserved
0x0008	Whether the motor is running or stopping
0x0010	Whether zero back is complete
0x0020	Drive ready
Other	Keep

2.2.16 0x2010 Position Homing

Object dictionary	Name	Property	Type	Range	The default value	Unit
0x2010	Home Position	R/W	UINT	0 to1	0	---

Setting the object to 01h clears the position value (the actual value of the position) in 0x6064.

Usually used in situations where the motor has been moving in one direction, the user needs to stop the motor at the appropriate time, clear the actual position value through this object, and then enable the motor again. Otherwise, the motor position counter has a saturation problem.

2.2.17 0x2011 control mode

Object dictionary	Name	Property	Type	Range	The default value	Unit
-------------------	------	----------	------	-------	-------------------	------

0x2011	Control mode	R/W/S	UINT	0to2	0	---
--------	--------------	-------	------	------	---	-----

Set the operating mode of the stepper motor.

0 - Open ring operation

1 - Closed-loop operation

2- Closed-loop operation/FOC mode

The ECR60 can only operate in open-loop mode, setting other values that are invalid.

2.2.18 0x2020 encoder resolution

Object dictionary	Name	Property	Type	Range	The default value	Unit
0x2020	Encoder Resolution	R/W/S	UINT	1000to65535	4000	Pulse/rev

When the operating mode of the stepper motor is closed, you need to set the corresponding encoder resolution for the motor to run one turn. After this parameter is set, you need to [save](#) to power on again for it to take effect. Only ECT60 products are valid.

2.2.19 0x2021 Encoder Position

Object dictionary	Name	Property	Type	Range	The default value	Unit
0x2021	Encoder Counter in one rev	R	UINT	1000to65535	0	Pulse/rev

This object reflects the position of the current motor in one circle. Only ECT60 products are valid.

2.2.20 0x2022 position differential alarm threshold

Object dictionary	Name	Property	Type	Range	The default value	Unit
-------------------	------	----------	------	-------	-------------------	------

0x2022	Position Trae Error Limit	R/W/S	UINT	1000to65535	4000	Pulse/rev
--------	------------------------------	-------	------	-------------	------	-----------

When the operating mode of the stepper motor is closed, when the position error exceeds this setting, the motor will alarm and disconnect the enable. This parameter is set immediately after it takes effect. Only ECT60 products are valid.

2.2.21 0x2023 Servo Mode 1 Control Parameters

Object dictionary	Name	Property	Type	Range	The default value	Note
0x2023:01	PosLoop_Kp	R/W/S	UINT	0 to 0 10000	2000	Proportional gain: Adjusting the motor position response rigidity
0x2023:02	PosLoop_Ki	R/W/S	UINT	0to 1000	100	Integral gain to eliminate positional errors when the motor is stationary.
0x2023:03	PosLoop_Kd	R/W/S	UINT	0 to 0 10000	200	
0x2023:04	PosLoop_Kvff	R/W/S	UINT	0 to100	30	Speed compensation
0x2023:05	PosLoop_Kdi	R/W/S	UINT	0 to500	0	Used to eliminate low-speed resonance Usually this gain cannot be greater than 200

This object takes effect only if the ECT60 is closed-loop control in servo mode 1. Gain is usually available by default.

2.2.22 0x2024 signal in place

Object dictionary	Name	Property	Type	Range	The default	Note
-------------------	------	----------	------	-------	-------------	------

					value	
0x2024:01	InPosMode	R/W/S	UINT	0 to10000	2000	Signal determination mode in place 0 - Detection at all times 1 - Detection after pulse command stop
0x2024:02	InPosCnt	R/W/S	UINT	0 to 1000	100	When the position error is less than the set pulse value and the time in place is continuously set, it is determined to be in place.
0x2024:03	InPosTime	R/W/S	UINT	0 to 10000	200	

This object is in closed-loop mode of the ECT60 and is used to detect whether the motor is within the set accuracy range.

2.2.23 0x2025 Servo Speed Filter

Object dictionary	Name	Property	Type	Range	The default value	Note
0x2025:01	FV1_HZ	R/W/S	UINT	0 to1000	200	Set the filter for servo mode 2
0x2025:02	FV2_HZ	R/W/S	UINT	0to2000	600	
0x2025:03	FPOUT_HZ	R/W/S	UINT	0 to5000	5000	

This object is effective under ECT60 servo mode 2 and is used to set the bandwidth of the speed ring feedback parameters

The FV1_HZ is used to set the speed feedback filtering a low-pass filter bandwidth.

FV2_HZ used to set the secondary low-pass filter bandwidth for velocity feedback filtering. Normally set $FV2HZ = 3 \times FV1_HZ$

FPOUT_HZ is used to set the bandwidth of the FOC speed ring output variable, usually by default.

2.2.24 0x2026 Servo Mode 2 Control Parameters

Object	Name	Propert	Type	Range	The	Note
--------	------	---------	------	-------	-----	------

dictionary		y			default value	
0x2026:01	PVIA_Kp	R/W/S	UINT	0 to 0 10000	2000	Position Proportional Gain: Adjusting motor position response rigidity
0x2026:02	PVIA_Ki	R/W/S	UINT	0to 1000	100	Integral gain to eliminate positional errors when the motor is stationary.
0x2026:03	PVIA_Kv1	R/W/S	UINT	0 to 0 10000	200	Speed Feedback Gain 1
0x2026:04	PVIA_Kv2	R/W/S	UINT	0 to100	30	Speed Feedback Gain 2
0x2026:05	PVIA_Kvff	R/W/S	UINT	0 to 500	0	Speed Feed-Forward Gain 1

This object takes effect under ECT60 in servo mode 2 and uses a vector control algorithm.

Usually PVIA_Kv1, PVIA_Kv2 , PVIA_Kvff

2.2.25 0x2043 speed Given

Object dictionary	Name	Property	Type	Range	The default value	Unit
0x2043	Speed Reference	R	UINT	-3000 to 3000	0	Rpm

This object reflects the given speed of the current motor.

2.2.26 0x2044 Speed Feedback

Object dictionary	Name	Property	Type	Range	The default value	Unit
0x2044	Speed Feedback	R	UINT	-3000 to 3000	0	Rpm

This object reflects the actual speed of the current motor.

The ECT60 returns the actual speed, and the value returned by eCR60 is the given speed.

2.2.27 0x2048 voltage

Object dictionary	Name	Property	Type	Range	The default value	Unit
0x2048	Bus Voltage	R	UINT	---	0	10mV

Bus voltage value (V) - object value /100;

2.2.28 0x2049 input level

Object dictionary	Name	Property	Type	Range	The default value	Unit
0x2049	Input Level	R	UINT	---	0	---

Show the physical level of the current IO input

Bit15 to bit6	Bit5	Bit4	Bit3	Bit2	Bit1	Bit0
---	IN6	IN5	IN4	IN3	IN2	IN1

0 - No input signal

1 - There is an input signal

2.2.29 0x204A output level

Object dictionary	Name	Property	Type	Range	The default value	Unit
0x204A	Output Level	R	UINT	---	0	---

Show the current physical level of the output port

Bit15 to bit2	Bit1	Bit0
---	OUT2	OUT1

0 - indicates that the current output port has output

1 - indicates that the current output port has no output

2.2.30 0x2060 First Resonance Point Harmonic Magnitude

Object dictionary	Name	Property	Type	Range	The default value	Unit
0x2060	Amplitude of First Anti-Vibration	R/W/S	UINT	0-1000	0	---

Used to eliminate the vibration of the first resonance point of a two-phase stepper motor.

This method cancels out resonance by adding a certain harmonic on the set current. The amplitude and phase of the harmonics need to be adjusted to eliminate vibration.

2.2.31 0x2061 First Resonance Point A Phase

Object dictionary	Name	Property	Type	Range	The default value	Unit
0x2060	Phase A of First Anti-Vibration	R/W/S	UINT	0-1024	0	---

Adjust the harmonic phase of the A-phase winding

2.2.32 0x2062 First Resonance Point B Phase

Object dictionary	Name	Property	Type	Range	The default value	Unit
0x204A	Phase B of First Anti-Vibration	R	UINT	0-1024	0	---

Adjust the harmonic phase of the B-phase winding

2.3 CIA402 Object Dictionary

2.3.1 0x603F fault code

Object dictionary	Name	Property	Type	Range	The default value
0x603F	Error Code	RW	UINT		0

When a failure occurs, the failure condition is first eliminated, and then 0x0080 is written to the control word 0x6040 to clear 0x603F.

The fault code is as follows:

Error Code	Describe
0x7500	Communication failure
0x3150	Voltage error inside phase A circuit
0x3151	Voltage error inside the B-phase circuit
0x8611	Closed-loop mode tracking error over-limit
0x2211	Overcurrent
0x3110	Overpressure

2.3.2 0x0640 Control Word

This object is used to control the state of the drive and motion. Can enable/prohibit the drive, motor start, stop, clear fault, etc.

Object dictionary	Name	Property	Type	Range	The default value
0x6040	Control Word	RW	UINT		0

The bit sits of the control word are defined as follows:

Bit	Describe
0	Switch ON
1	Enable Voltage
2	Quick Stop
3	Enable Operation
4	Operating mode-related
5	Operating mode-related
6	Operating mode-related
7	Fault reset
8	Time out
9	Operating mode-related
10-15	Keep

Detailed combination description of Bit 0 to 3 and Bit7:

Command	Control the bit				
	Bit7	Bit3	Bit2	Bit1	Bit0
Shutdown	0	X	1	1	0
Switch on	0	0	1	1	1
Switch on and Enable operation	0	1	1	1	1
Disable voltage	0	X	X	0	X
Quick stop	0	X	0	1	X
Disable Operation	0	0	1	1	1
Enable Operation	0	1	1	1	1
Fault reset	0- 1	X	X	X	X

Definition of snr 4, 5, 6, 8, 9 in the relevant mode

PP mode

Bit	Name	Value	Describe
4	A new target location	0- 1	Change from 0 to 1 to set a new target position
5	Keep		
6	Absolute/relative	0	Absolute position mode
		1	Relative position mode
8	Time out	0	Motor waiting to complete positioning
		1	Stop Run
9	Keep		

PV mode

Bit	Name	Value	Describe
8	Pause/Run	0	Motor runs to set speed
		1	The motor slows down to 0 and stops

Back to home mode

Bit	Name	Value	Describe
4	Start back to home	0- 1	Start back to home
8	Time out	0	Controlled by bit4
		1	Stop back to home

2.3.3 0x6041 Status Word

This object sets the probe function.

Object Type	Data Type	Access Type	PDO Mapping	Default Value
Var	UNSIGNED16	RW	Yes	0

The register bits are defined as follows:

Bit	Describe
0	Ready To Switch ON
1	Switch ON
2	Operation Enabled
3	Fault
4	Voltage Enabled
5	Quick Stop
6	Switch On Disabled
7	Warning
8	Keep
9	Remote
10	Target Reach
11-15	Keep

Bit 9: Remote

Shows whether the control word is set. This bit bit expresss control word has settled.

2.3.4 0x6060 operating mode

Used to set the operating mode.

Object dictionary	Name	Property	Type	Range	The default value
0x6060	Mode of Operation	RW	INTEGER8		0

The EC Series drives support the following operating modes:

Value	Mode
1	Profile Position Mode (PP)
3	Profile Velocity Mode (PV)
6	Homing Mode (HM)

2.3.5 0x6061 Operating Mode Display

Displays the current operating mode, defined with 0x6060.

Object dictionary	Name	Property	Type	Range	The default value
0x6061	Mode of Operation Display	R	INTEGER8		0

2.3.6 0x6064 Actual location

Shows the actual position of the current motor, in Pulse

Object dictionary	Name	Property	Type	Range	The default value
0x6064	Position Actual Value	R	INTEGER32		0

2.3.7 0x606C Actual Speed

Shows the actual position of the current motor in Pulse

Object dictionary	Name	Property	Type	Range	The default value
0x6064	Position Actual Velocity	R	INTEGER32		0

2.3.8 0x607A Target Position

This object sets the target position in PP mode and CSP mode. The unit is Pulse.

Object dictionary	Name	Property	Type	Range	The default value
0x607A	Profile Target Position	RW	INTEGER32		0

In PP mode, bit6(0x6040.6) of the control word is used to set the coordinates to be relatively absolute.

In CSP mode, this target position is absolute position mode.

2.3.9 0x607C zero bias

This object is used to set the zero sensor's offset from position 0. The unit is Pulse.

Object dictionary	Name	Property	Type	Range	The default value
0x607C	Home Offset	RW	INTEGER32		0

2.3.10 0x6081 Track Speed

This object is used to set the maximum speed of the trapezoidal and deceleration instruction stoais in PP mode. In Pulse/s

Object dictionary	Name	Property	Type	Range	The default value
0x6081	Profile Velocity	RW	INTEGER32		10000

2.3.11 0x6083 Track Acceleration

This object is used to set the acceleration of pp mode, PV mode, trapezoidal plus deceleration instruction, in Pulse/s

Object dictionary	Name	Property	Type	Range	The default value
0x6083	Profile S.	RW	INTEGER32		100000

2.3.12 0x6084 Track Deceleration

This object is used to set PP mode, PV mode, trapezoidal plus deceleration instruction of the reduction speed, in Pulse/s

Object dictionary	Name	Property	Type	Range	The default
-------------------	------	----------	------	-------	-------------

y					value
0x6084	Profile Deceleration	RW	INTEGER32		100000

2.3.13 0x6085 Quick Stop Deceleration

This object is used to set PP mode, PV mode, HOME mode, when the limit, zero point and other sensors, the motor stops the reduction speed. The unit is Pulse/s.

Object dictionary	Name	Property	Type	Range	The default value
0x6085	Quickstop Declaration	RW	INTEGER32		500000

2.3.14 0x6098 Zero-zero method

This object is used to set the method for the motor to return to zero.

Object dictionary	Name	Property	Type	Range	The default value
0x6098	Homing Method	RW	UNSIGNED16	17 to 35	17

The specific description refers [to the back to zero mode](#) .

2.3.15 0x6099 Zero Speed

This object sets the speed at which the motor returns to zero.

Object dictionary	Name	Property	Type	Range	The default value	Unit
0x6099:01	Homing Velocity (fast)	R/W/S	UNSIGNED16	65535	10000	Pulse/s
0x6099:02	Homing Velocity (slow)	R/W/S	UNSIGNED16	65535	2000	Pulse/s

2.3.16 0x609A Zero-zero acceleration

This object is used to set the acceleration and deceleration of the position curve when the motor returns to zero. The unit is Pulse/s.

Object dictionary	Name	Property	Type	Range	The default value
0x609A	Homing Ense	RW	UNSIGNED32		100000

2.3.17 0x60B8 probe function settings

This object sets the probe function.

Object Type	Data Type	Access Type	PDO Mapping	Default Value
Var	UNSIGNED16	RW	Yes	0

The register bits are defined as follows:

Bit	Value	Definition
0	0	Probe 1 is prohibited
	1	Probe 1 enables
1		Keep
2		Keep
3		Keep
4	0	Prohibit probe 1 drops along latch
	1	Enable probe 1 to rise along the latch
5	0	Prohibit probe 1 drops along latch
	1	Enable probe 1 drops along latch
6		Keep
7		Keep
8	0	Probe 2 Prohibited
	1	Probe 2 Enable
9		Keep
10		Keep
11		Keep
12	0	Prohibit probe 2 drops along latch
	1	Enable probe 2 rise edge latch
13	0	Prohibit probe 2 drops along latch
	1	Enable probe 2 drops along latch
14		Keep
15		Keep

The positive position is locked at the rising edge moment and the negative position is locked at the falling edge moment.

2.3.18 0x60B9 Probe Status

This object defines the probe functional state.

Object Type	Data Type	Access Type	PDO Mapping	Default Value
Var	UNS116	R	Yes	0

The status bits are defined as follows:

Bit	Value	Definition
0	0	Probe 1 is prohibited
	1	Probe 1 enables
1	0	Probe 1 Rise Edge Latch : None
	1	Probe 1 rises along latch : Yes
2	0	Probe 1 drops along latch : None
	1	Probe 1 drops along latch : There
3-7	0	Keep
8	0	Probe 2 is prohibited
	1	Probe 2 Enable
9	0	Probe 2 Rise Edge Latch: None
	1	Probe 2 rise spout lock: There
10	0	Probe 2 drops along latch: None
	1	Probe 2 drops along latch: There
11-15	0	Keep

2.3.19 0x60BA probe 1 positive latching value

This object saves the position where the probe 1 rises along the latch.

Object Type	Data Type	Access Type	PDO Mapping	Default Value
Var	UNSIGNED32	R	Yes	0

2.3.20 0x60BB probe 1 negative latchvalue

This object saves probe 1 drops along the latched position.

Object Type	Data Type	Access Type	PDO Mapping	Default Value
-------------	-----------	-------------	-------------	---------------

Var	UNSIGNED32	R	Yes	0
-----	------------	---	-----	---

2.3.21 **0x60BC** probe 2 positive latching value

This object saves the position where the probe 2 rises along the latch.

Object Type	Data Type	Access Type	PDO Mapping	Default Value
Var	UNSIGNED32	R	Yes	0

2.3.22 **0x60BD** probe 2 negative latching value

This object saves probe 2 drops along the latchposition.

Object Type	Data Type	Access Type	PDO Mapping	Default Value
Var	UNSIGNED32	R	Yes	0

2.3.23 0x60FD Digital Inputs

This object monitors the input port of the drive.

Object Type	Data Type	Access Type	PDO Mapping	Default Value
Var	UNSIGNED	Ro	Yes	0x00000000

Bit0	CW Limit	0 - Invalid 1 - Limit stake effective
Bit1	CCW Limits	
Bit2	HOME	0 - Zero invalid 1 - Zero effective
Bit3 to Bit15	Keep	
Bit16	IN1	The physical state of the input port 0 - The input signal is invalid 1 - Input signal valid
Bit17	IN2	
Bit18	IN3	
Bit19	IN4	
Bit20	IN5	
Bit21	IN6	
Bit22 to Bit31	Keep	

2.3.24 0x60FF PV mode speed setting

Speed when this object sets PV mode, in Pulse/s

Object dictionary	Name	Property	Type	Range	The default value	Unit
0x60FF	Target Velocity	RW	DINT		0	Pulse/s

This object is 32-bit signed data, with positive and negative values representing the two directions in which the motor is running.

2.3.25 Operating mode supported by 0x6502

This object describes the operating mode supported by the drive.

Object dictionary	Name	Property	Type	Range	The default value	Unit
0x6052	Supportdrive Drive Modes	R	UDINT		0x000000A5(165)	---

The bits are defined as follows:

Bit	Description
0	PP: Profile Position Mode
1	VI: Velocity Mode
2	PV: Profile Velocity Mode
3	TQ: Torque Profile Mode
4	reserved
5	HM: Homing Mode
6	IP: Interpolated Position Mode
7	CSP: Cyclic Sync Position Mode
8	CSV: Cyclic Sync Velocity Mode
9	Cyclic Sync Torque Mode
10-31	Keep

Bit value : 0: Not supported

Bit value s 1: Support

THE EC SERIES STEP PERTERIATED DRIVES SUPPORT PP, PV, HM, CSP MODES.

2.4 CIA402 Motion Control

2.4.1 Operating mode

The ECR series EtherCAT step drive supports the following operating modes (0x6060):

Profile Position (PP)

Profile Velocity (PV)

Cyclic Dynamic Position (CSP)

Homing (HM)

2.4.2 PP Track Position Mode

Track position mode description:

Standard position mode is a point-to-point mode that uses setpoints consisting of speed, acceleration, deceleration, and target position. Once all these parameters are set, the drive caches these commands and starts executing the setpoint.

Enable Track Position Mode

To be able to track position mode, the value of the object dictionary 6060h (operating mode) must be set to 0001h. The object dictionary 6061h (operation mode display) can be used to confirm that the drive is in the correct operating mode.

Set run parameters

Use the object dictionary 607Ah, 6081h, 6083h, 6084h to set position, speed, acceleration, and deceleration respectively.

Start and stop

When powered on, the drive is in a non-enabled state. The control word 6040h is written to 0006h, which will put the drive into the "ready to switch on" state.

Indicate a new set point and start the movement by sending 001Fh to the control word of the object dictionary 6040h.

To enable drive operation, the value 001Fh must be written to the object dictionary address of the control word 6040 h. This also means that a new set point is ready. The driver uses Bit 12 of the status word (6041h) to indicate receipt of a valid setting point.

Because the set point is triggered by the edge, once the drive receives and processes the set point, the control word must be cleared by writing 000FH to the control word register.

Control word-related bits Controlword Bits

New set point (bit 4) - set this bit high to lock in a new set-point. Once the drive has received the setpoint, bit12 of the status word will be set to high (1) and bit4 of the control word to be set to 0;

Setpoint change (bit 9) - If it is low, the drive enters an idle state after the current setpoint has been executed, waiting for the next new set point. If high, the drive runs the set point of the previous set speed, then switches to the new speed and runs to the new set point.

Setpoint effective immediately (bit 5) - If this bit is high and the new setpoint is effective immediately, the motor will run to the new position at the speed of the new setpoint.

Absolute/Relative Mode (bit 6) - If high, the set point is relative position mode. For example, if the front motor position is 10000 steps and the new set point is 20000, the final position will be 30000. If low, set the point absolute position mode. If the previous motor position is 10000 and the newly set position is 20000, the new position will be 20000. (The distance from the previous position to the new position is 10,000 steps). Do not change this bit as the motor moves.

The [control word](#) associated with the PP mode.

2.4.3 PV Track Speed Mode

Track Speed Mode Description

Track speed mode is a relatively simple mode of operation. Once the speed, acceleration and deceleration are set, the driver commands the motor to accelerate to operating speed according to the acceleration parameters, or stops the movement according to the deceleration parameters.

The following illustration shows an example of a configuration speed pattern.

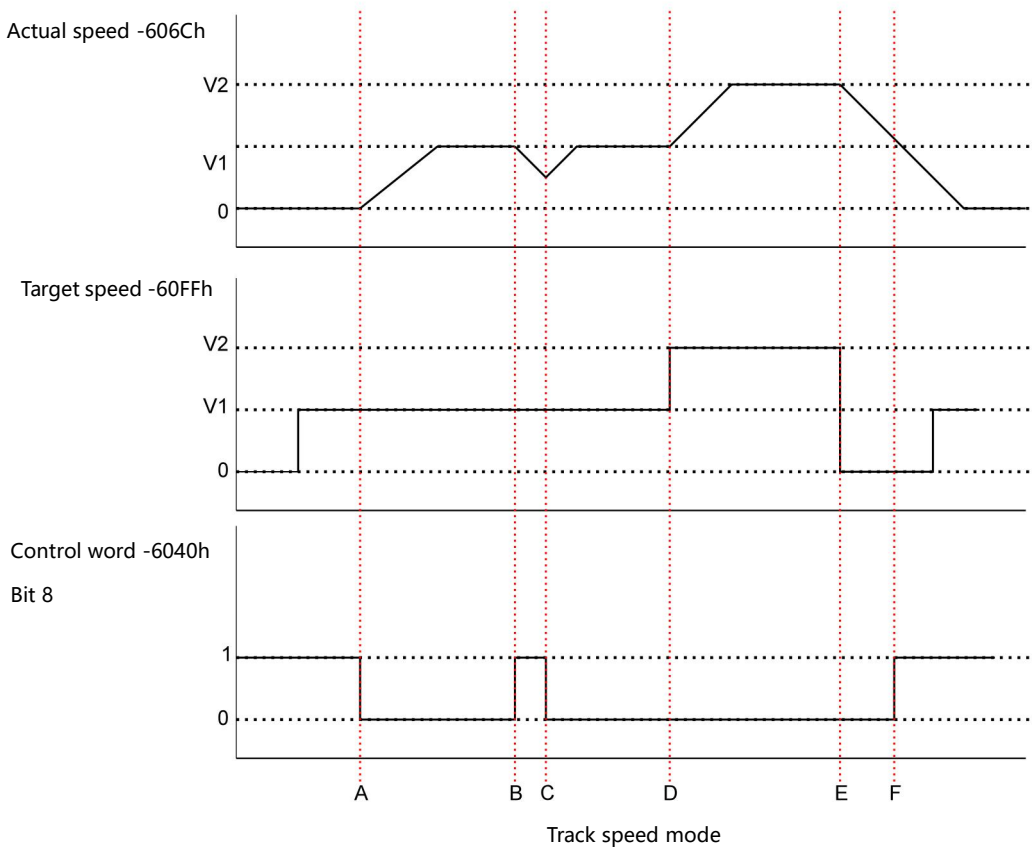

The figure above shows the correspondence between the motor's operating status, actual speed, target speed and control word.

	Target speed	6040h Stop Bit4	Motor motion
Begin	0	1	Motor stop
A	V1	1 - 0	Motor accelerates to V1
B	V1	0 - 1	Motor slows down to stop

C	V1	1 - 0	The motor has not stopped and is accelerating to V1.
D	V1 - V2	0	Motor accelerates from V1 to V2
E	V2 - 0	0	Motor deceleration from V2 to 0
F	0	0 - 1	Motor stop
G	0 - V1	1	Motor stop

The table above explains how the stop bit and target speed can be used together to affect the motor speed. Between points B and C, the motor does not stop completely, but decelerates at the trajectory deceleration value that starts at point B. When a bit conversion is stopped at point C, it immediately accelerates back to the target speed. At point E, reducing the target speed to zero is the same as using the stop bit.

It should be noted that the powerful moment is kept on the motor whether the stop bit is set and the target speed is set to zero. If you want the shaft to move freely, you must place the drive in a drive-disabled (non-enabled) state.

Enable Track Speed Mode

To be able to track position mode, the value of the object dictionary 6060h (operating mode) must be set to 0003h. The object dictionary 6061h (operation mode display) can be used to confirm that the drive is in the correct operating mode.

Set run parameters

Use the object dictionary 60FFh, 6083h, 6084h to set the speed, acceleration, and deceleration of the trajectory speed mode.

Enable Drive

When powered on, the drive is in a non-enabled state. The control word 6040h is written to 0006h, which will put the drive into the "ready to switch on" state. Write 010Fh to

6040h, causing the drive to enter the "Operation Enabled" state and the motor to stop running.

Start and stop

To start and stop the movement, switch the control word stop bit (bit 8 bits). When the stop bit is set to 0 (000Fh), the motion starts or continues, and when the stop bit is set to 1 (010Fh), the motion stops.

Track speed (60FFh) greater than zero indicates the motor is moving forward, less than zero indicates motor reversal, equal to zero means motor stop. The user can set the motor into a reverse state directly when the motor is in positive motion, and the motor will slow down and accelerate in reverse to the set speed.

2.4.4 CSP Sync Location Mode

Synchronized location mode description

In this mode, the primary controller generates a position trace and sends the target location (0x607A) to the drive during each PDO update cycle. The drive feeds back the actual motor position and optional actual motor speed and torque.

Enable CSP mode

To enable the circular synchronization location mode, the value 0008h must be written to 6060 h at the dictionary address.

Enable Drive

When powered on, the drive is in a non-enabled state. The control word 6040h is written to 0006h, which will put the drive into the "ready to switch on" state. Once again, write the value of 0x000F to 6040h, the drive will be in the enabling state, the motor can respond to the CSP instructions.

2.4.5 Probe function

Probe function Locks motor position information through the digital input port. The eCR60's digital input port functionality and polarity can be self-defined by

[0x2007,0x2008](#).

The probe function-related object dictionary is as follows:

Index	Object description	
0x60B8	Probe function settings	Touch Probe Function
0x60B9	Probe status	Touch Probe Status
0x60BA	Probe 1 rises along the latch position	Touch Probe Position 1 Positive Value
0x60B	Probe 1 drops along the latch position	Touch Probe Position 1 Negative Value
0x60BC	Probe 2 rises along the latch position	Touch Probe Position 2 Positive Value
0x60BD	Probe 2 drops along the latch position	Touch Probe Position 2 Negative Value

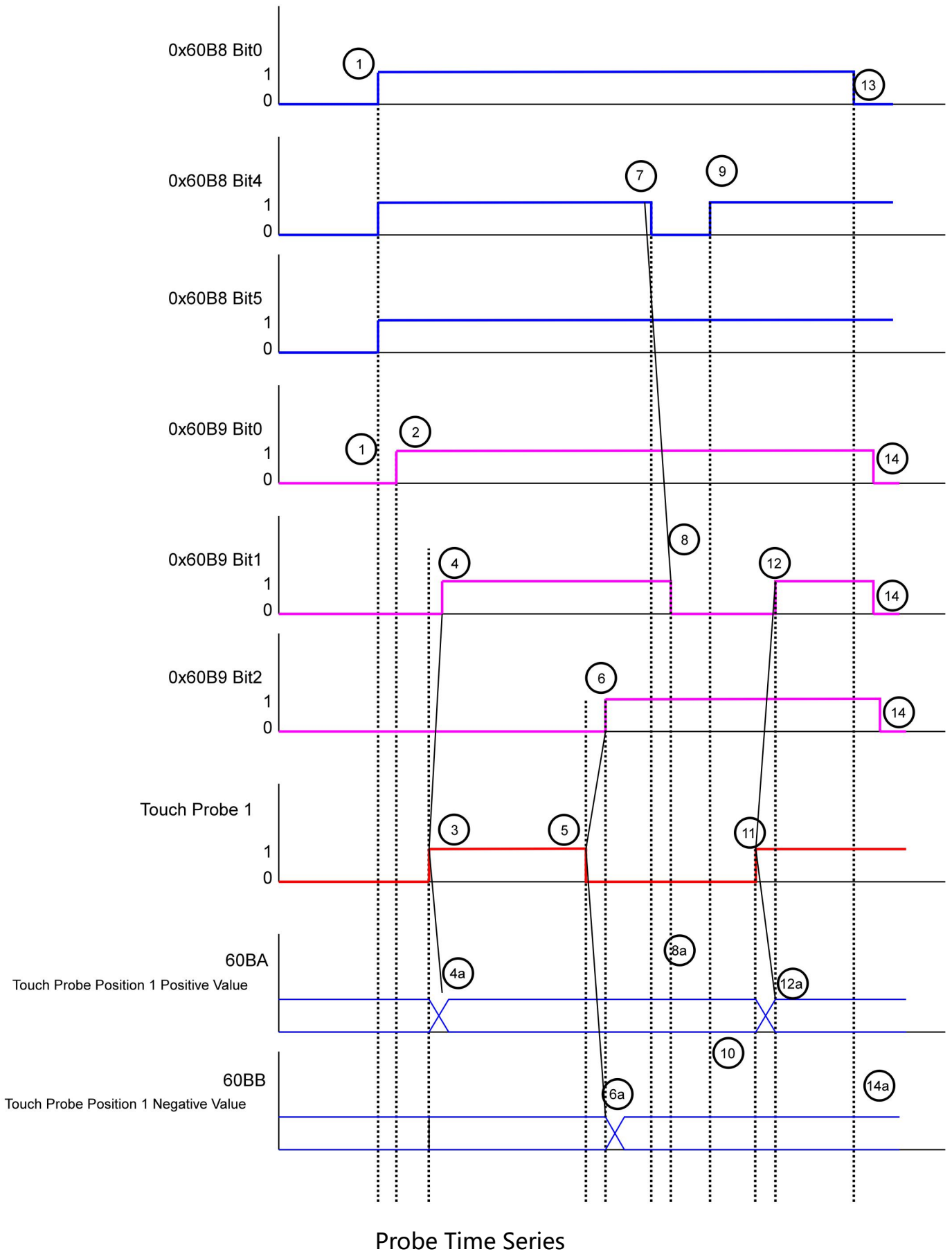

Serial number	Register changes	Probe action
1	60B8 Bit 0 s 1 60B8 Bit 1,4,5	Enable probe 1 Configure the up and down edge of the enable probe
2	- 60B9 Bit 0 0 s 1	Status "Probe 1 Enable" is placed
3	The rising edge of the external probe signal	
4	- 60B9 Bit 1 s 1	Status "Probe 1 rise son latch" is placed
4a	- 60BA	Probe 1 positive position is locked
5	The external probe signal drops on the edge	
6	- 60B9 Bit 2 s 1	Status "Probe 1 drops along latch" is placed
6a	- 60BB	Probe 1 negative position is locked
7	- 60B8 Bit:4	Rising edge latch function: Prohibited
8	- 60B9 Bit 0 0	Status "Probe 1 Rise Along Latch" cleared
8a	- 60BA	Probe 1 positive position, no change in latch position
9	- 60B8 Bit 4 s 1	Rising edge latch function: Enable
10	- 60BA	Probe 1 positive position, no change in latch position
11	The rising edge of the external probe signal	
12	- 60B9 Bit 1 s 1	Status "Probe 1 rise son latch" is placed
12a	- 60BA	Probe 1 positive position is locked

13	- 60B8 Bit 0 0	Probe 1 function: prohibited
14	- 60B9 Bit 0,1,2 s 0	Status bits cleared
14a	- 60BA, 60BB	Probe 1 positive/negative latch position unchanged

Probe Timing Description

2.4.6 Back to zero mode

Set back to zero parameters

Set back to zero speed, acceleration, zero offset and related sensor input signal.

The relevant object dictionary is as follows:

Object dictionary	Description
0x607C	Zero offset
0x6098	Zero-back method setting
0x6099	Zero-back speed
0x609A	Back zero and deceleration
0x2007	Input port feature selection
0x2008	Enter port polarity settings

Enable zero function:

To be able to track position mode, the value of the object dictionary 6060h (operating mode) must be set to 0006h. The object dictionary 6061h (operation mode display) can be used to confirm that the drive is in the correct operating mode.

After the drive is initially powered on, it is in a non-enabled state. Write to the control word 6040h 6, set the drive to the "ready to switch on" state, then write 000Fh to the control word 6040h, set the drive to "Operation Mode Mode".

Start back to zero:

The back zero method is set up through the 6098h object dictionary.

Set the speed back to zero by 0x6099.

By controlling the bit4 of the word 6040h, from 0 to 1 on the rising edge, you can start back to zero. The status of zeroback is queried by 6041 status word.

Abort Back to Zero function:

The back zero method is set up through the 6098h object dictionary. By controlling bit8of the word 6040h,the rising edge from 0 to 1 can be aborted back to zero. The status of zeroback is queried by 6041 status word.

2. 4. 6. 1 Zero-back method

The ECR60 drive product supports the way back to the origin of 17 to 34,35, as described below.

2. 4. 6. 3 Method 17:

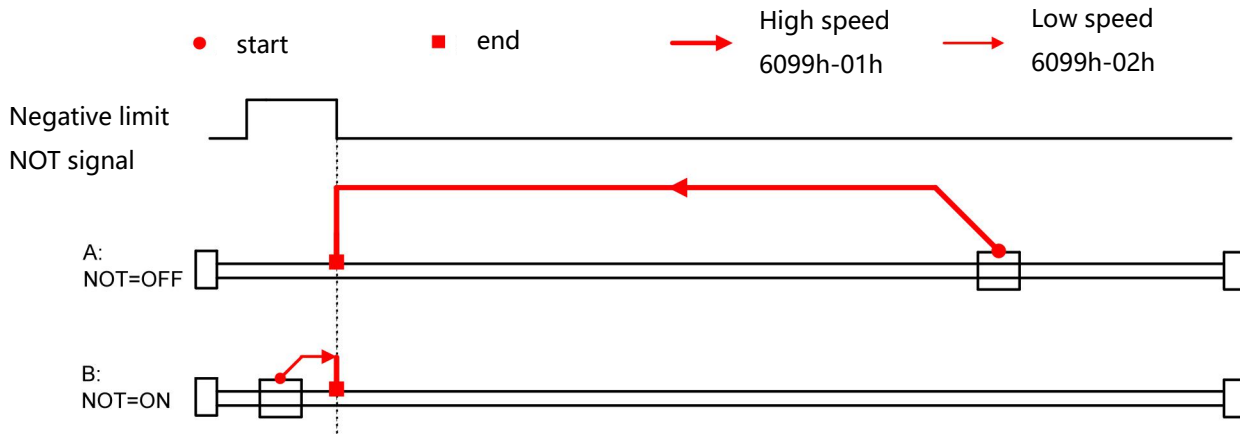

2. 4. 6. 4 Method 18:

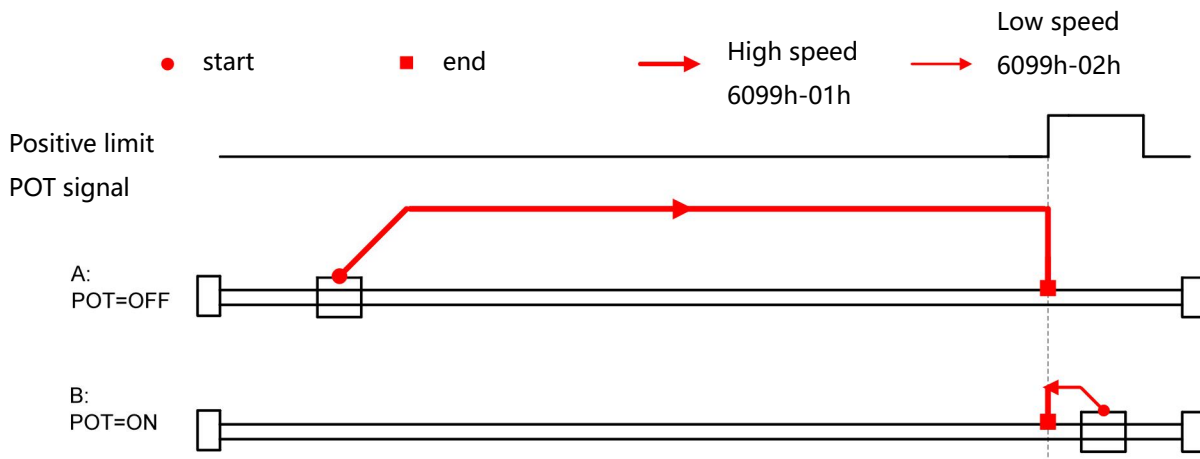

Method 19:

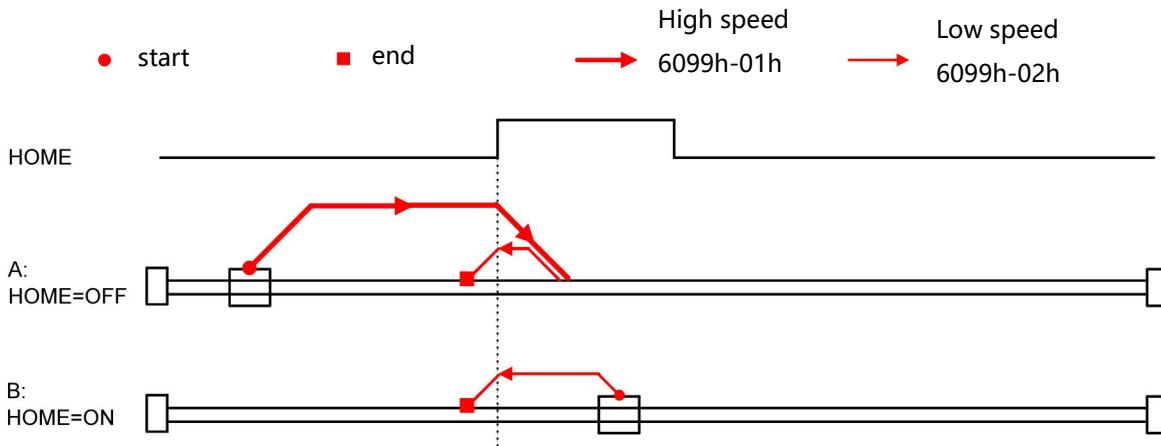

Method 20:

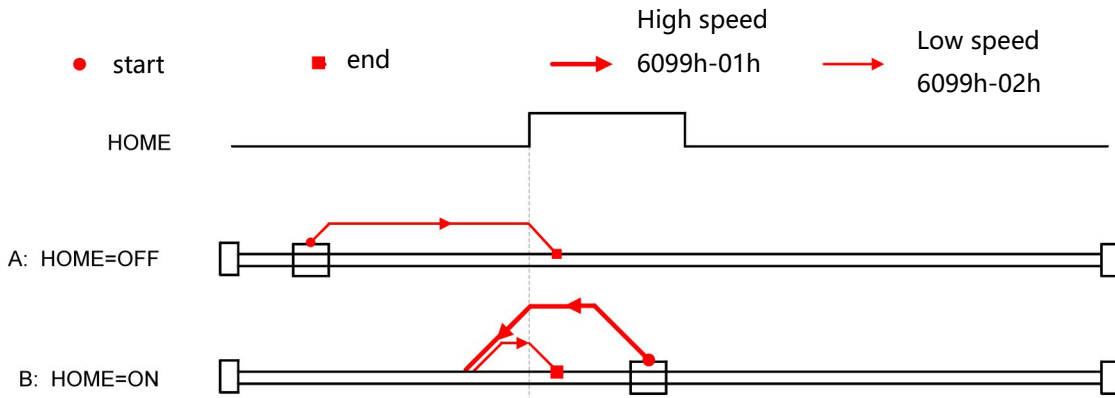

2. 4. 6. 7 Method 21:

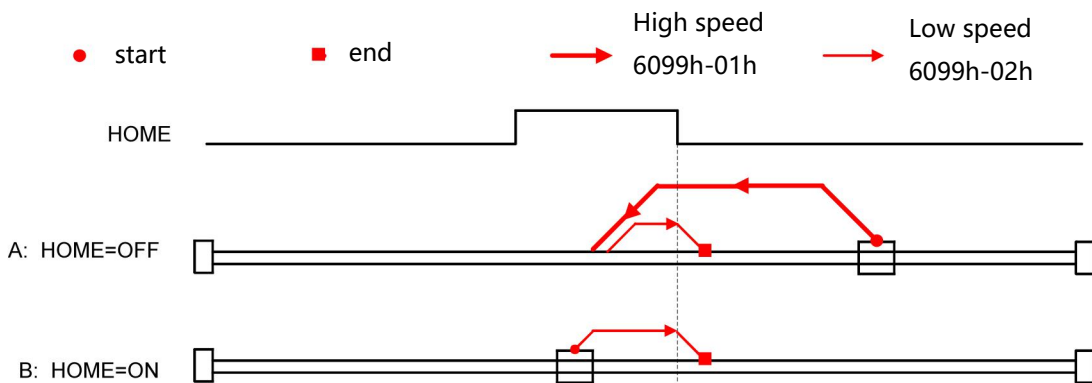

2. 4. 6. 8 Method 22:

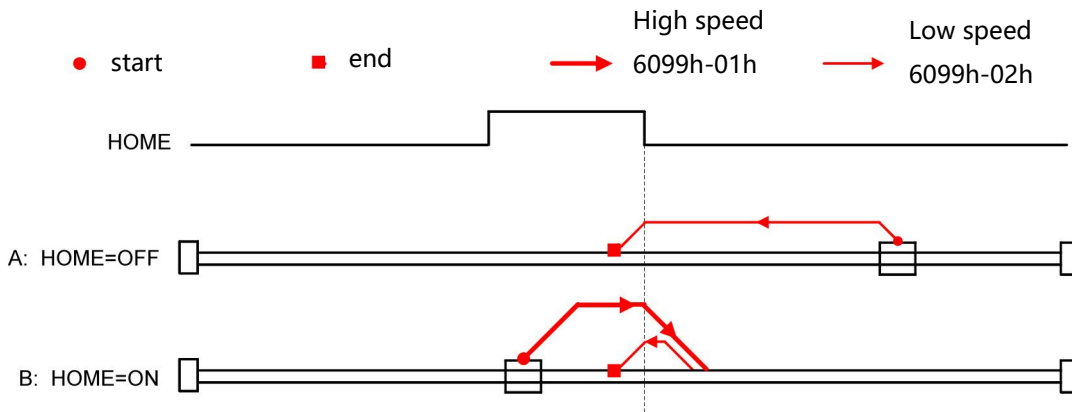

2. 4. 6. 9 Method 23

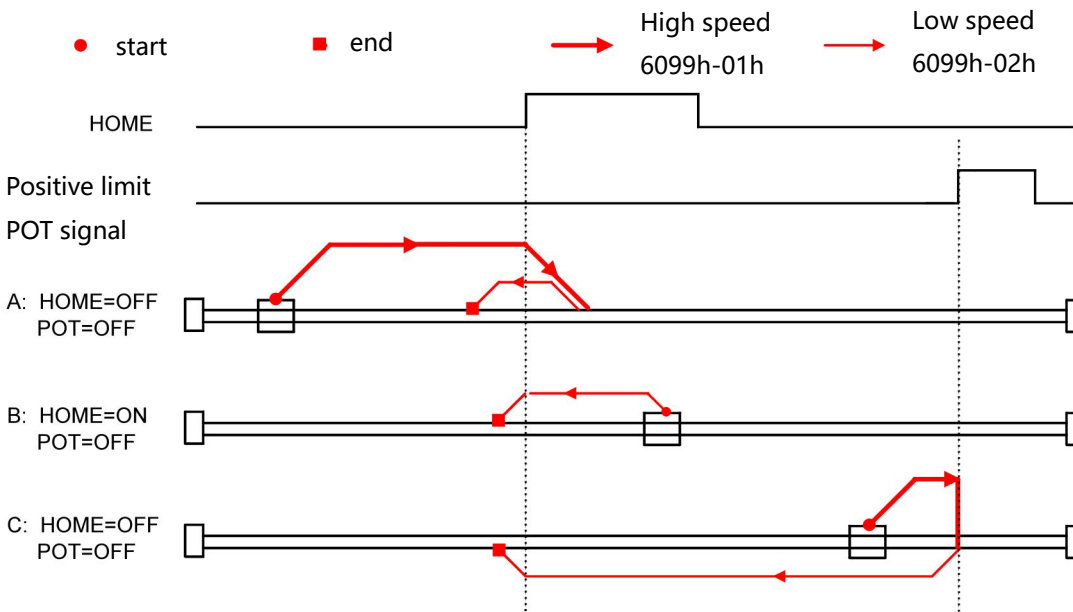

2. 4. 6. 10 Method 24

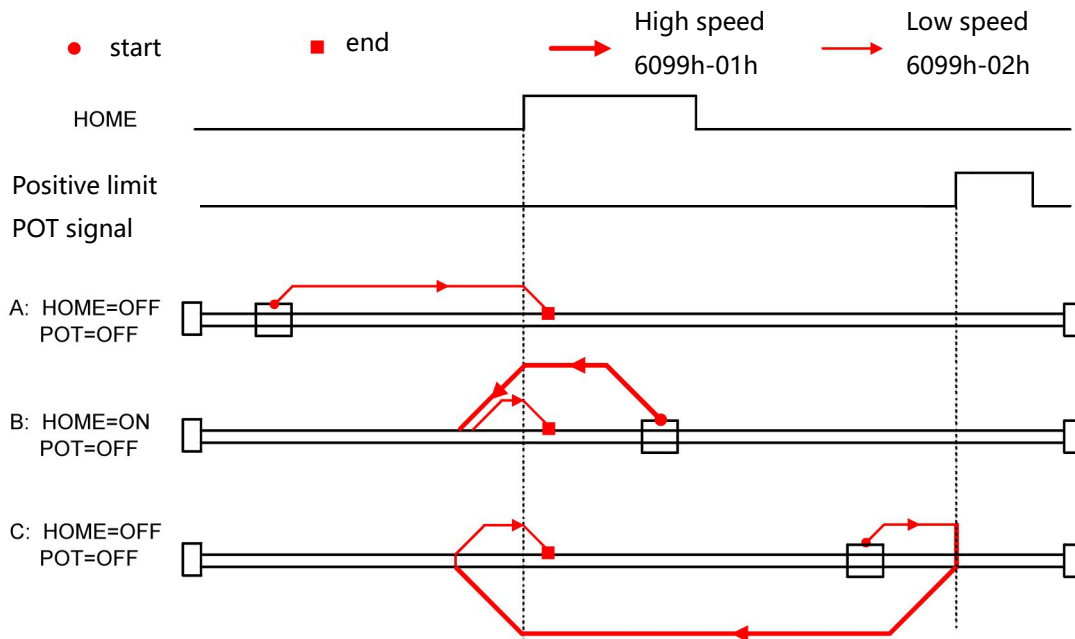

2. 4. 6. 11 Method 25:

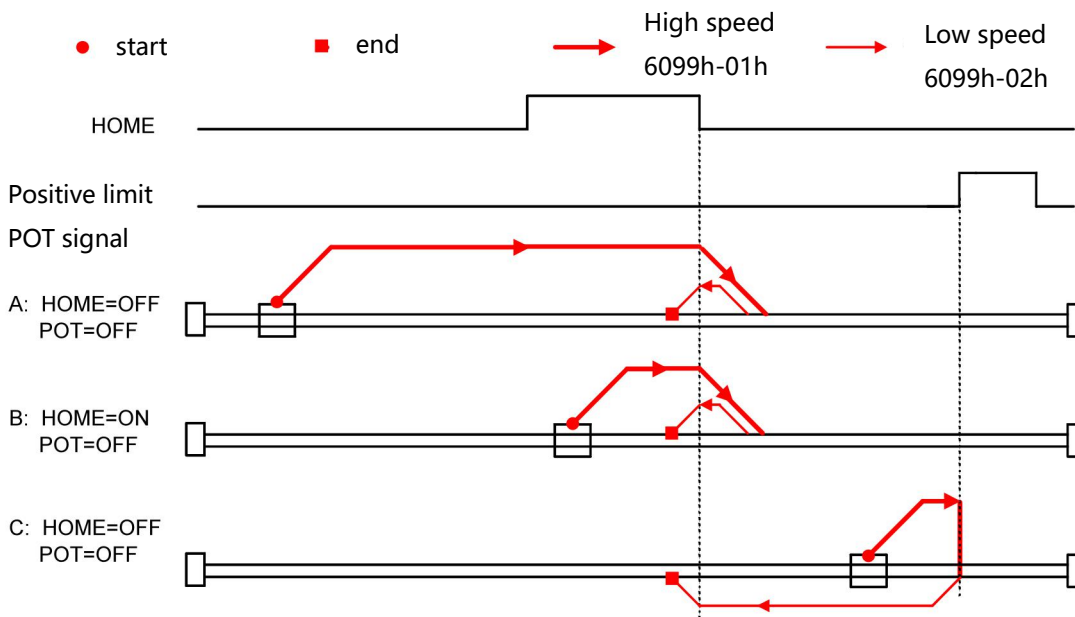

2. 4. 6. 12 Method 26:

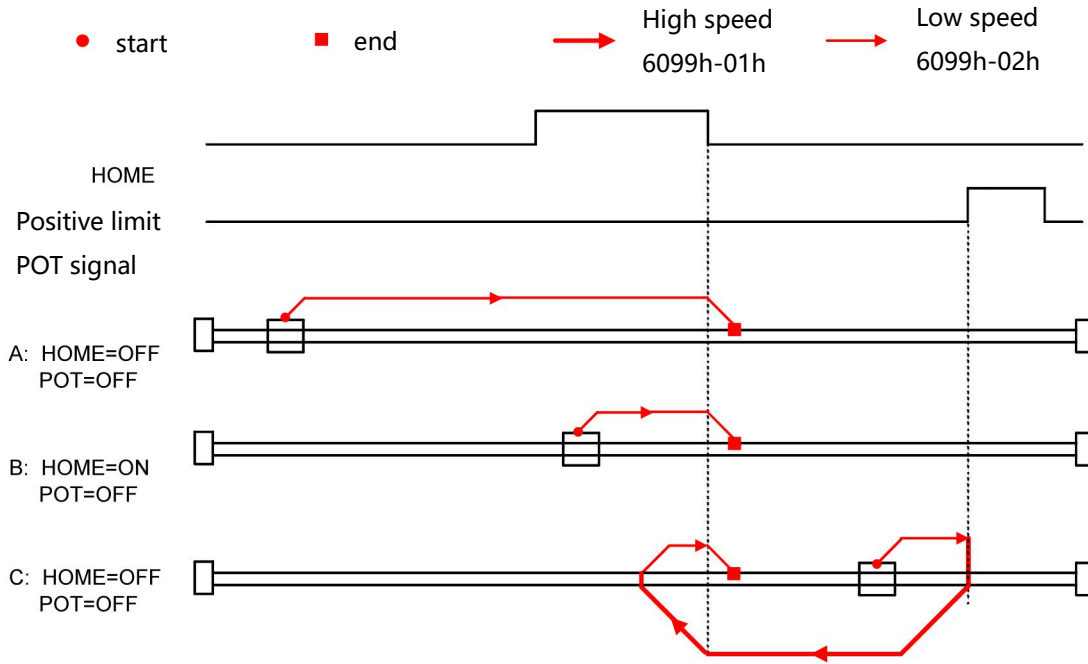

2. 4. 6. 13 Method 27:

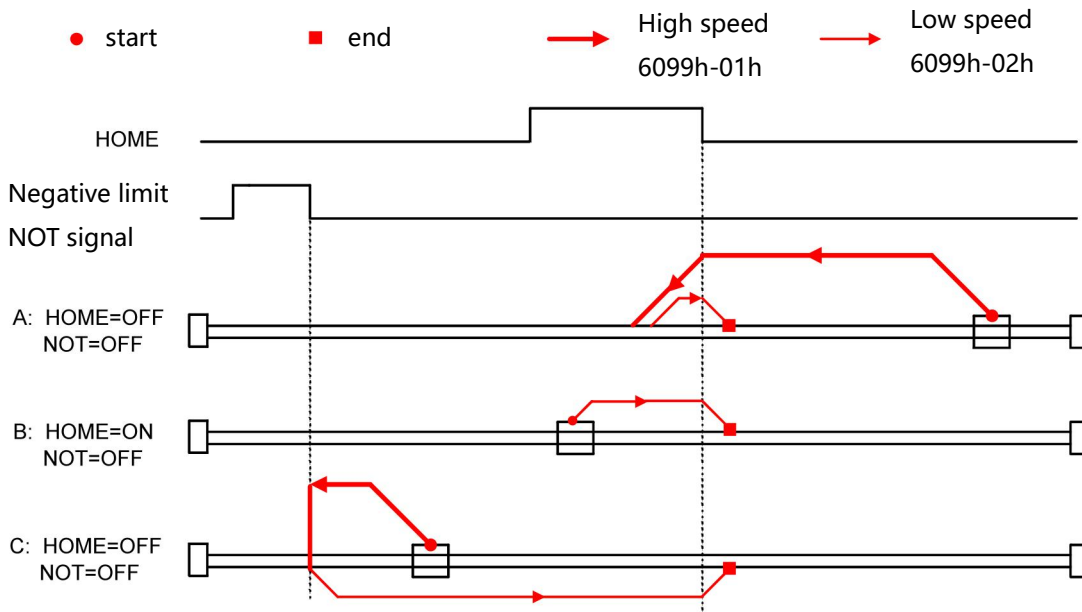

2. 4. 6. 14 Method 28:

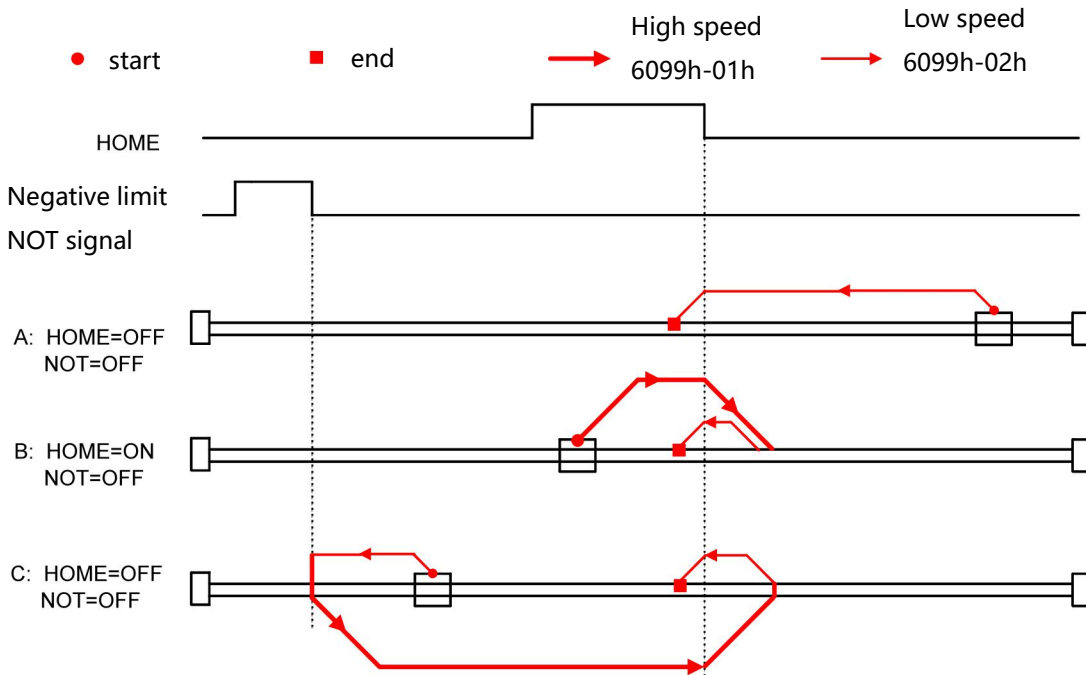

2. 4. 6. 15 Method 29:

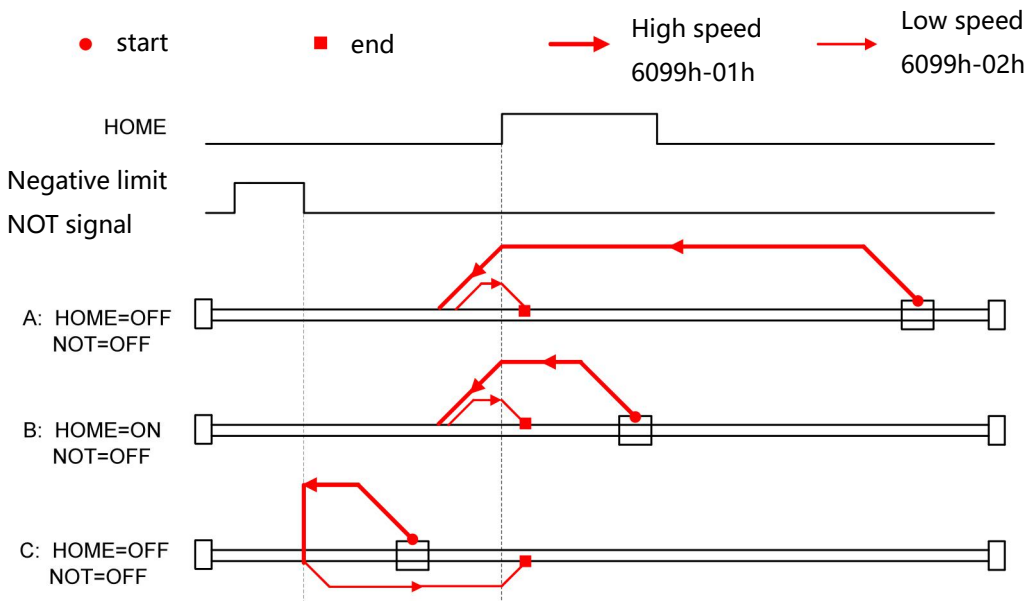

2. 4. 6. 16 Method 30:

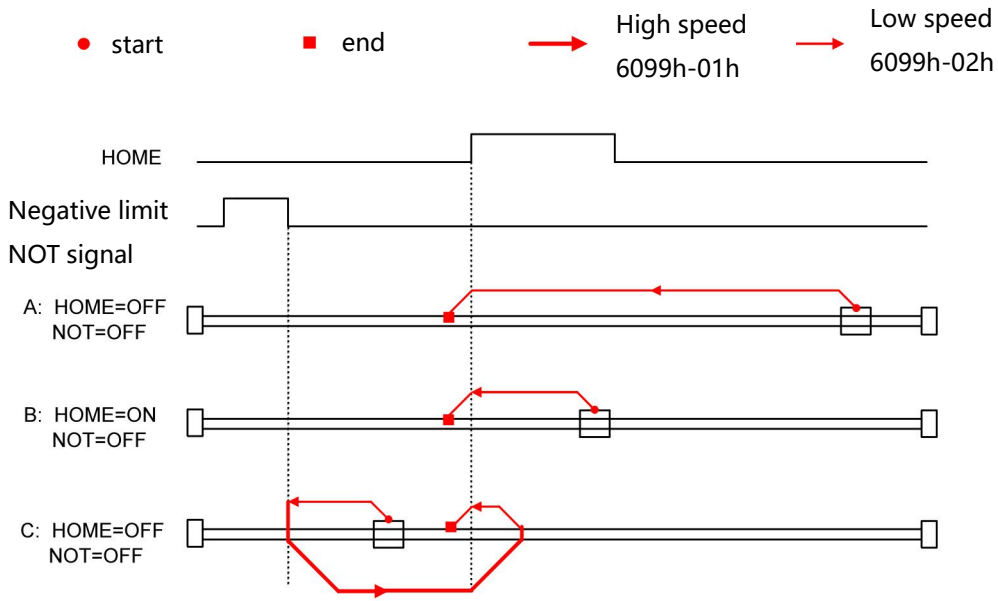

2. 4. 6. 17 Method 35:

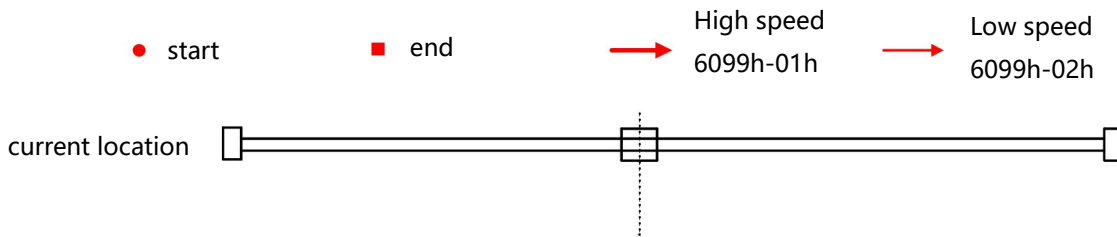

Contact RTELLIGENT

Rtelligent Head

B301,ZHUANGBIAN INDUSTRIAL PARK NANCHANG ROAD, GUSHU, BAOAN

DISTRICT,SHENZHEN,CHINA

Phone: : 86 (0)755 29503086

Fax: 86 (0)755 23327086

Email: sales@szruitech.com

East China Office

Shanghai Songjiang District Shenbrick Highway 5555, also commercial building 9, room

328

Contact: Mr. Zou

Phone: 1811749519

Email: sales03@szruitech.com

Shandong Office

Unit 601 of The 22nd Building of Xinjie City Street, Tianqiao District, Jinan City, Shandong

Province

Contact: Mr. Deer

Phone: 13854109911

Email: sales06@szruitech.com