

ECR Series User Manual



Shenzhen Rtelligent Mechanical Electrical Technology Co., Ltd

Revision history

V202

- 1、 Add the phase loss detection function, when 0x2056 bit7 is 1, enable the phase loss detection.
- 2、 PP, PV mode status flag perfect, homing parameter 0x6099 change to standard 32bit, the previous version is 16bit, non-standard
- 3、 homing method 0x6098 change to INT8 type, before the UINT16 is non-standard
- 4、 Add control support for three-phase motors
- 5、 Add CSV mode
- 6、 Add ECR86/ECT86 product description
- 7、 Product version unified upgrade to V202

— Driver Description

1.1 Product Introduction

Thank you for choosing the Rtelligent ECR series stepper motor driver. ECR series is a high performance bus control stepper motor driver, while integrating the functions of intelligent motion controller. ECR series EtherCAT drivers can be run as standard EtherCAT slave and support CoE (CANopenover).

1.1.1 Characteristics

- Support CoE (CANopen over EtherCAT), meet CiA 402 standards
- Support CSP, PP, PV, Homing mode
- The minimum synchronization period is 500us
- Dual port RJ45 connector for EtherCAT communication
- Control methods: open loop control, closed loop control / FOC control (ECT series support)
- Motor type: two phase, three phase;
- Digital IO port:

6 channels optically isolated digital signal inputs: IN1 and IN2 are 5V differential inputs, and can also be connected as 5V single-ended inputs; IN3 ~ IN6 are 24V single-ended inputs, common anode connection;

2 channels optically isolated digital signal outputs, maximum tolerance voltage 30V, maximum pouring or pulling current 100mA, common cathode connection method.

1.1.2 Electrical characteristics

ECR series product specifications

Product model	ECR42	ECR60	ECR86
Output current (A)	0.1~2A	0.5~6A	0.5~7A

Default current (mA)	450	3000	6000
Power supply voltage	24~80VDC	24~80VDC	24~100VDC / 24~80VAC
Matched motor	Below 42 base	Below 60 base	Below 86 base
Encoder interface	none		
Encoder resolution	none		
Optical isolation input	6 channels: 2 channels of 5V differential input, 4 channels of common anode 24V input		
Optical isolation output	2 channels: alarm, brake, in place and general output		
Communication interface	Dual RJ45, with communication LED indication		

**Please do not exceed the scope of use specified above.*

**Before enabling the motor, the user needs to set the operating current according to the motor specifications, otherwise the current setting beyond the rated range may cause the motor to burn.*

1.2 Power and motor

Model			Description
ECR42	ECR60	ECR86	
V+		AC	For ECR42、 ECR60, the power supply is DC power supply, V+ is connected to the positive pole of the power supply, and V- is connected to the negative pole of the power supply. The recommended power supply voltage is 24~80VDC.. For ECR86, the power supply is AC and DC compatible power supply. AC and AC can input 24~100V DC power, and can also input 24~80V AC power. <i>*The above power supply voltage is the limit value of the driver. Due to the influence of the back electromotive force of the stepper motor, the customer needs to reserve a certain voltage margin when using it.</i>
V-		AC	
A+	A+		Two-phase stepper motor winding connection port. Arbitrarily reversing A+, A- or B+, B- windings can make the motor run in the opposite direction.
A-	A-		
B+	B+		
B-	B-		

1.3 Digital input and output ports

The ECR series stepper driver has 6 optically isolated digital input ports and 2 optically isolated digital output ports.

1.3.1 Digital input port

The ECR series stepper driver has 6 digital input ports and 2 digital output ports. The object dictionary 0x2007 is the function setting of the input port, and 0x2008 is the polarity setting of the input port.

Note: IN1+ / IN1-, IN2+ / IN2- are 5V input terminals, please do not directly connect input signals higher than this voltage, otherwise the driver will be damaged!

The schematic diagram of the input port is shown below, and the user can connect the system according to the schematic diagram.

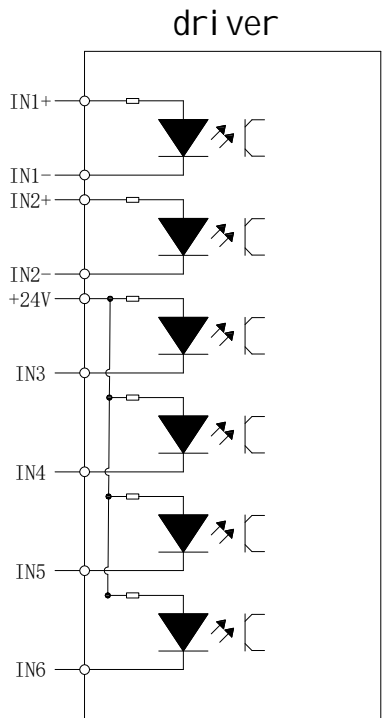

IN1+ / IN1-, IN2+ / IN2- are differential input terminals.

IN1 and IN2 are reserved external motor encoders, which constitute a closed-loop system.

ECR60 cannot receive encoder signals, only ECT60 can.

ECR Series User Manual
5V differential input

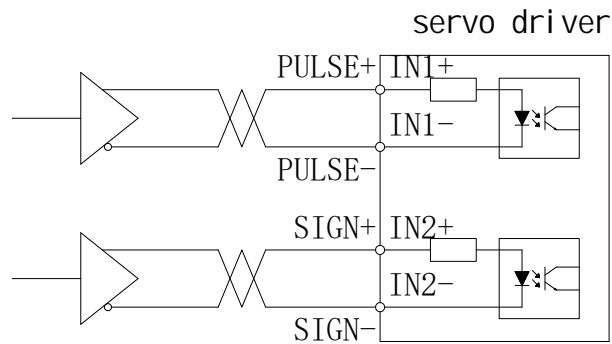

5V single-ended input

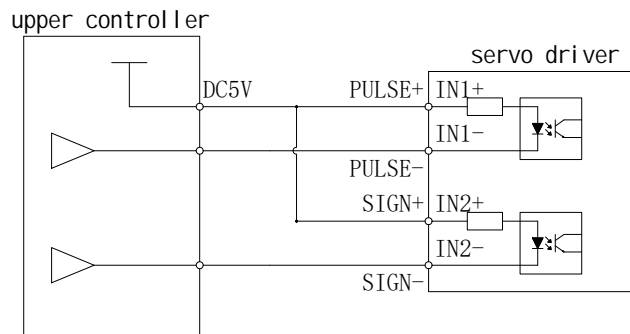

Note: When the IN1 and IN2 ports use 24V input, please connect a 2K current limiting resistor in series, otherwise the driver will be damaged.

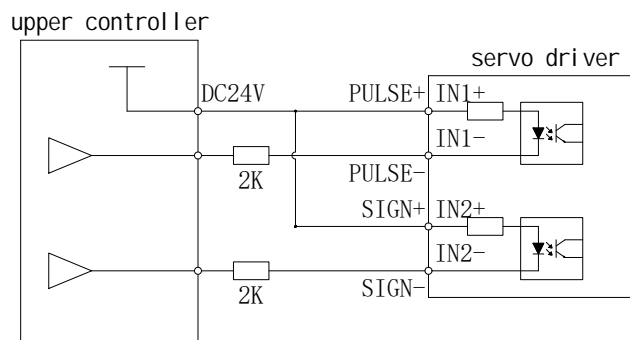

IN3~IN6 are single-ended input terminal

Taking IN3 as an example, the interface circuits of IN3 ~ IN6 are the same.

When the upper device is a relay output:



When the upper device is open collector output:

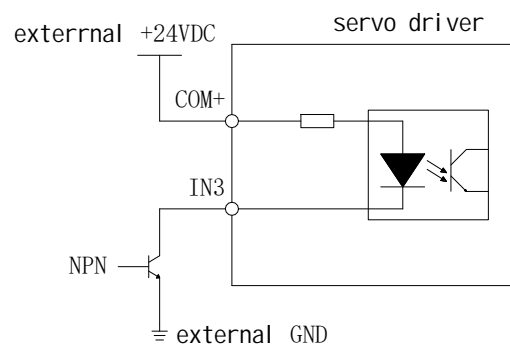

Note: PNP input is not supported

1.3.2 Digital output port

ECR series contains two optically isolated output signals.

OUT1 output current capacity up to 30 mA.

OUT2 output current capacity up to 150 mA.

By default, the digital output is all open points, the function of output port can be selected through object dictionary 2005, and object dictionary 2006 is used to set the polarity of output port.

Object Dictionary	Name	Property	Type	Scope	Default	Unit	Remarks
0x2005: 01	Output Port 1 function	R/W/S	UINT	0~3	1	---	Output port function selection: 0—— Custom output 1—— Alarm output 2—— Brake output 3—— In-place output
0x2005: 02	Output port 2 function	R/W/S	UINT	0~3	2	---	

0x2006	Output port polarity setting	R/W/S	UINT	0~3	3	---	Set the normally open and normally closed characteristics of the output port 0 - normally closed 1 - normally open
--------	------------------------------	-------	------	-----	---	-----	--

servo driver

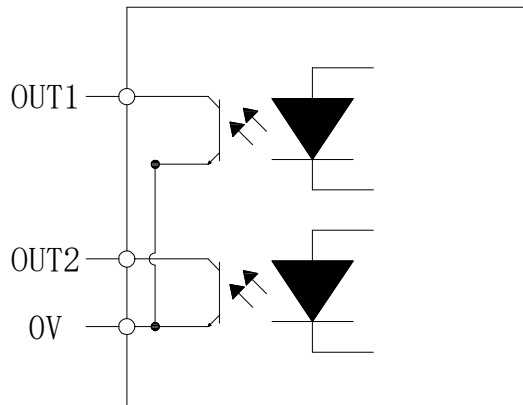

Taking OUT1 as an example, the OUT1~OUT2 interface circuit is the same.

When the upper device is relay input:

Correct wiring diagram:

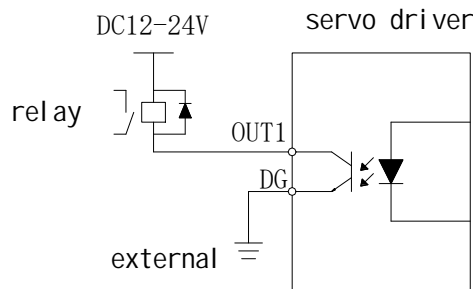

Wrong wiring diagram:

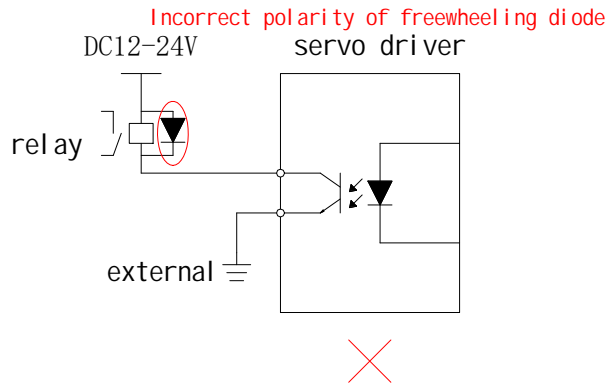
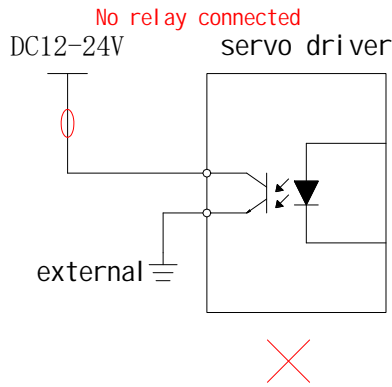

When the upper device is optocoupler input:

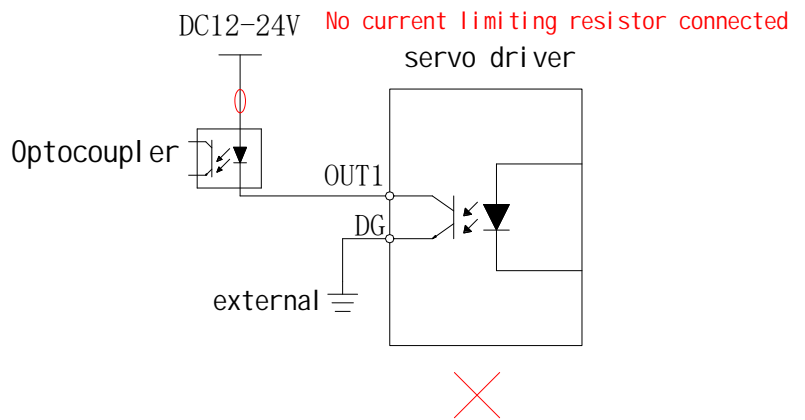
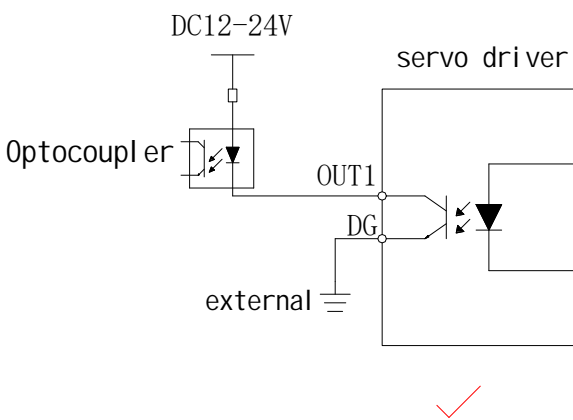

1.4 Connection EtherCAT

Please use CAT5E (or higher level) network cable.

The Ethernet input interface IN is connected to the Ethernet output interface OUT of the previous driver on the controller or the bus. The Ethernet output interface OUT is connected to the Ethernet input interface IN of the next driver on the bus. If the driver is the last node on the bus, you only need to connect the Ethernet input interface IN.

1.4.1 EtherCAT status indicator

The yellow light of RJ45 is used for Link status, indicating whether there is a network cable connection.

The green light of RJ45 is used for Activity state, indicating whether there is data communication.

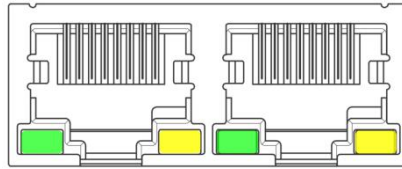

RUN/ERRLED indicator:

LED	Color	Status	Description
RUN	Green	Not bright	initialization status
		Slow Flash	pre-operational status
		Single flash	safe-operational status
		Always bright	operational status
ERR	Red	Not bright	No error
		Slow Flash	General error
		Single flash	Synchronization error
		Double flash	Watchdog error

Fast flash: bright for 50ms, dark for 50ms (10Hz). So cycle.

Slow flash: bright for 200ms, dark for 200ms (2.5Hz). So cycle.

Single flash: bright for 200ms, dark for 1s. So cycle.

Double flash: bright for 200ms, dark for 200ms, bright for 200ms, dark for 1s. So cycle.

1.5 EtherCAT site address







The EC series supports two methods to set the slave address: object dictionary 0x2150 to set the site alias and ESC to set the site alias, and select through the object dictionary 0x2151.

The default 0x2151 is 0, and the node address is allocated by the master station and saved in the EEPROM.

When users need to set their own fixed address, they need to set 0x2151 to 1, and then write the required address value in 0x2150.

0x2151	0x2150	Site address
0	1001	Master station configures site aliases to ESC EEPROM 0x0004 word addresses
1	Set value	Object dictionary 2150 sets the value to the node address value

1.6 Alarm code

LED status	Driver status
	Green light on constantly Driver not enabled
	Green light flashing The driver works fine
	1 Green, 1 Red Driver overcurrent
	1 Green, 2 Red Driver input power overvoltage
	1 Green, 3 Red Driver internal voltage error
	1 Green, 6 Red Parameter check error
	1 Green, 7 Red Motor winding phase loss

1.7 Mechanical dimensions

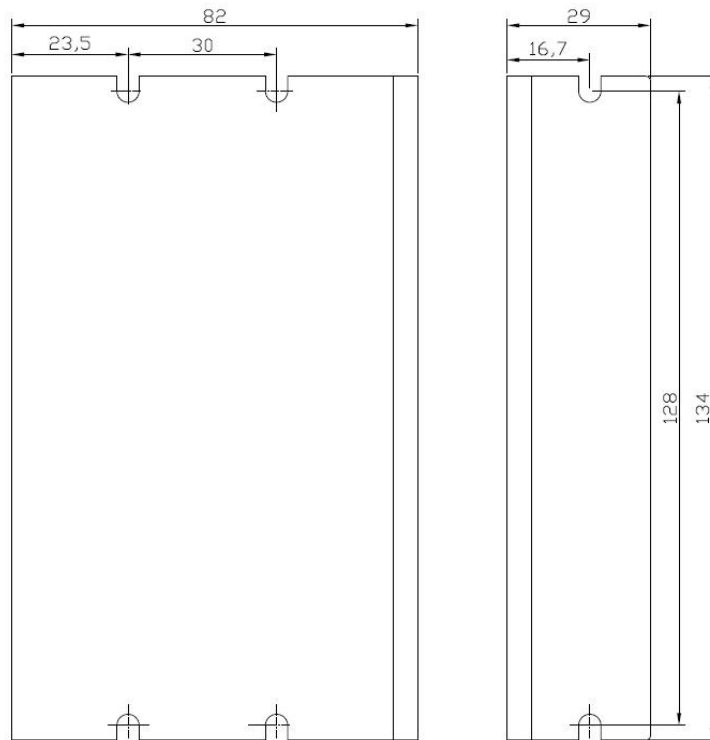

ECR42、ECR60 Installation size

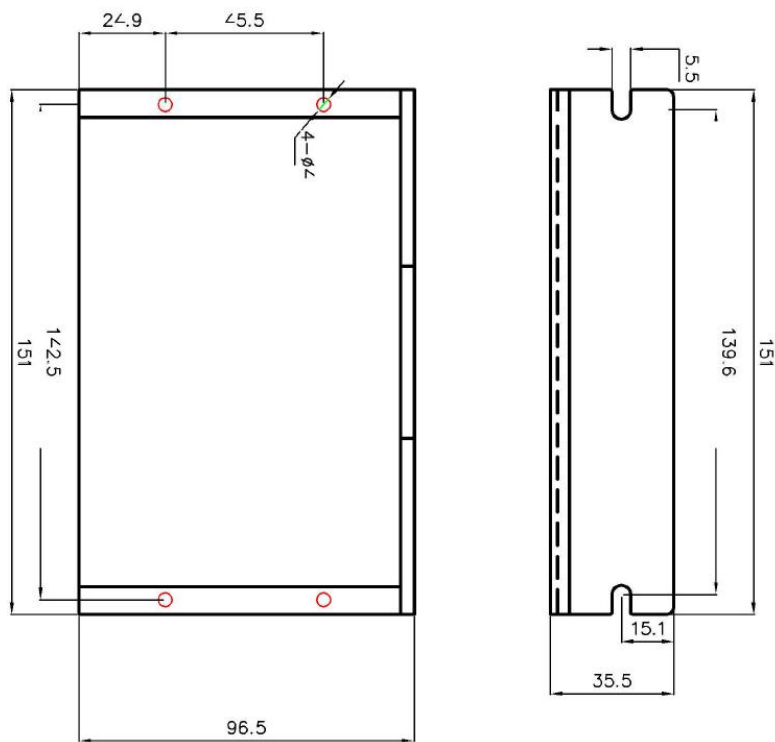

ECR86 Installation size

二 Parameter Description and Settings

2.1 General parameters

2.1.1 0x1000 Type of device

Object Type	Data Type	Access Type	PDO Mapping	Default Value
VAR	UNSIGNED32	RO	NO	0x00040192

Bit 0~15: Device profile number 0x0192: CiA402

Bit 16~31: Additional information 0x0004: Stepper Drive

2.1.2 0x1001 Device name

Displays the model of current driver.

The function of ECR42 is the same as ECR60. It only limits the default current of the drive to prevent users from matching small motors without modifying the current of the driver at the first time, resulting in excessive current and damaging the driver and motor. On 0x1001, both show "ECR60".

Object Type	Data Type	Access Type	PDO Mapping	Default Value
VAR	Visible string	RO	NO	ECR60

ECT60

Object Type	Data Type	Access Type	PDO Mapping	Default Value
VAR	Visible string	RO	NO	ECT60

2.1.3 0x1009 Hardware version

Object Type	Data Type	Access Type	PDO Mapping	Default Value
VAR	Visible string	RO	NO	0xA1

2.1.4 0x100A Software version

Object Type	Data Type	Access Type	PDO Mapping	Default Value
VAR	Visible string	RO	NO	0x101B

2.1.5 Save parameters

Sub-index of object dictionary 0x1010: 01 Write 1 to save current parameters.

When saving the parameters, first stop the motor running, then save the parameters.

The data structure is as follows:

Index	Sub-index	Name	PDO mapping	Default
1010	00	Maximum number of sub-indexes	No	1
	01	Save parameters	No	0

2.1.6 Restore factory settings

Sub-index of object dictionary 0x1011: 01 Write 1, and then power on again to restore the driver to the factory state.

When restoring the factory setting, first stop the motor running, then save the parameters.

Index	Sub-index	Name	PDO mapping	Default
1011	00	Maximum number of sub-indexes	No	1
	01	Save parameters	No	0

2.2 Manufacturer-specific object

2.2.1 0x2000 Operating current

Object Dictionary	Name	Property	Type	Scope	Default	Unit
0x2000	Peak Current	R/W/S	UINT	100~6000	3000	mA

This object is used to set the sinusoidal peak current when the stepper motor is running in open loop.

2.2.2 0x2001 Subdivision/resolution

Object Dictionary	Name	Property	Type	Scope	Default	Unit
0x2001	Motor Resolution	R/W/S	UINT	200~65535	10000	Pulse/rev

This object is used to set the number of pulses required to run the motor for one revolution

when the stepper motor is running in open loop.

ECT60 default to works in closed loop mode, the number of pulses required to run the motor for one revolution is set by the 0x2020 encoder resolution.

2.2.3 0x2002 Standby time

Object Dictionary	Name	Property	Type	Scope	Default	Unit
0x2002	Idle Time	R/W/S	UINT	200~65535	500	ms

This object is used to set the time for the stepper motor to enter the standby state after it stops running when the stepper motor is running in open loop.

2.2.4 0x2003 Percentage of standby current

Object Dictionary	Name	Property	Type	Scope	Default	Unit
0x2003	Idle Current Percent	R/W/S	UINT	0~100	50	%

This object is used to set the percentage of the holding current relative to the operating current set by 0x2000 when the stepper motor is running in open loop and the motor stops running and enters the standby state.

2.2.5 0x2005 Output Port Function

Object Dictionary	Name	Property	Type	Scope	Default	Unit
0x2005:01	Output 1 Function	R/W/S	UINT	0~3	1	---
0x2005:02	Output 2 Function	R/W/S	UINT	0~3	2	---

ECR60 contains two output ports, this object is used to set the function corresponding to the output port.

The port function is defined as follows:

Value	Function
0	Custom output
1	Alarm output
2	Brake output
3	In place output

When set as a custom output, the state of the port can be controlled by the polarity setting of 0x2006.

2.2.6 0x2006 Output port polarity

Object Dictionary	Name	Property	Type	Scope	Default	Unit
0x2006	Outputs Polarity	R/W/S	UINT	0~3	3	---

Set the normally open and normally closed characteristics of the output port: Bit0 is the polarity setting for output port 1, Bit1 is the polarity setting for output port 2.

0—— Normally closed

1—— Normally open

Bit15~bit2	Bit1	Bit0
---	OUT2	OUT1

2.2.7 0x2007 Input port function

Object Dictionary	Name	Property	Type	Scope	Default	Unit
0x2007:01	Input 1 Function	R/W/S	UINT	0~8	0	---
0x2007:02	Input 2 Function	R/W/S	UINT	0~8	0	---
0x2007:03	Input 3 Function	R/W/S	UINT	0~8	1	---
0x2007:04	Input 4 Function	R/W/S	UINT	0~8	2	---
0x2007:05	Input 5 Function	R/W/S	UINT	0~8	3	---
0x2007:06	Input 6Function	R/W/S	UINT	0~8	6	---

ECR60 contains 6 input ports, this object is used to set the corresponding function of the input port.

Value	Function
0	General input port
1	CW limit input
2	CCW limit input

3	HOME input
4	Fault clearance
5	Emergency stop signal
6	Motor offline
7	Probe 1
8	Probe 2

The state of the input port can be read through the 0x60FD object.

The polarity of the input port can be set by the 0x2008 object.

2.2.8 0x2008 Input port polarity

Object Dictionary	Name	Property	Type	Scope	Default	Unit
0x2008	Inputs Polarity	R/W/S	UINT	0~3F	0x3F	---

Each bit defines the polarity of the corresponding port. Bit 0 defines the polarity of input port 1:

Bit15~bit6	Bit5	Bit4	Bit3	Bit2	Bit1	Bit0
---	IN6	IN5	IN4	IN3	IN2	IN1

0——Normally closed, 1——Normally open

2.2.9 0x2009 Filter time

Object Dictionary	Name	Property	Type	Scope	Default	Unit
0x2009	Filter Time	R/W/S	UINT	0~25600	6400	us

The ECR60 has a built-in sliding average filter, and this object is used to set the time of the sliding average filter. The larger the filter time, the smoother the motor starts and stops, but the greater the motor response lag.

$$\text{Lag time} = \text{filter time}$$

2.2.10 0x200A Shaft lock time

Object Dictionary	Name	Property	Type	Scope	Default	Unit
0x2009	Soft lock Time	R/W/S	UINT	0~65535	1000	50us

When ECR60 is enabled, the stepper motor needs to be locked for initial positioning. In order to

reduce the jitter of initial positioning, ECR60 has a built-in ramp-locking function. This object is used to set the ramp time of the motor shaft lock when the motor is enabled.

$$\text{Shaft lock time} = \text{set value} * 50\mu\text{s} * 2 = \text{set value} * 100\mu\text{s}$$

2.2.11 0x200B Current loop parameters

Object Dictionary	Name	Property	Type	Scope	Default	Remarks
0x200B:01	AutoPI enable	R/W/S	UINT	0~1	1	The driver identify the motor parameters while positioning for the first time and automatically calculates the PI gain 0-- disable; 1-- enable
0x200B:02	lloop_Kp	R/W/S	UINT	100~65535	1000	0x200B: When 01 is 1, this register cannot be set.
0x200B:03	lloop_Ki	R/W/S	UINT	0~10000	200	When it is 0, users can set
0x200B:04	lloop_Kc	R/W/S	UINT	0~1024	256	Anti-integral saturation coefficient

ECR60 uses current control to achieve subdivision operation of stepper motors. ECR60 adopts automatic parameter recognition algorithm by default to recognize the electrical parameters of the motor and automatically calculate the appropriate current loop PI parameters. When the automatically identified PI parameters cannot meet the requirements, users can set the parameters by themselves.

2.2.12 0x200C Motor parameters

Object Dictionary	Name	Property	Type	Scope	Default	Remarks
0x200C:01	Motor type	R/W/S	UINT	0~1	0	0—— Two-phase stepper motor 1—— Three-phase stepper motor
0x200C:02	Resistance Auto	R	UINT	100~	1000	When automatic PI is

				65535		turned on, the motor winding resistance value is recognized. Unit: mOhm
0x200C:03	Inductance Auto	R	UINT	0~10	1	When automatic PI is turned on, the motor winding inductance value is recognized. Unit: mH
0x200C:04	Resistance Set	R/W/S	UINT	0~10000	1000	Motor winding resistance value Unit: mOhm
0x200C:05	Inductance Set	R/W/S	UINT	1~10	1	Motor winding inductance value Unit: mH
0x200C:06	BEMF coefficient	R/W/S	UINT	0~1000	256	ECT60

Open loop and servo mode 1:

When ECR60 driver controls stepper motor in open loop mode and ECT60 driver works in servo mode 1, the motor parameters themselves do not participate in motor control, and the user does not need to make special settings. The user can judge whether the motor connection is normal by checking the self-identifying resistance and inductance of the object.

Servo mode 2:

When ECT60 driver works in servo mode 2, the closed-loop stepper motor is in FOC control mode. Due to the special structure of the stepper motor, a weak magnetic control is required for FOC control. The weak magnetic control parameters are estimated from the motor's resistance, inductance and back EMF coefficient.

Usually the automatically estimated resistance and inductance can meet the demand, and the user can also set the resistance and inductance by themselves according to the motor parameters of the motor manufacturer. The calculation of back-EMF coefficient can be calculated by the following formula:

$$0x200C:06 = (\text{rated torque (N.M)} / \text{rated current(A)}) * 500$$

2.2.13 0x200D Run reverse

Object Dictionary	Name	Property	Type	Scope	Default	Unit
0x200D	Invert motor direction	R/W/S	UINT	0~1	0	---

If the forward direction of the motor is inconsistent with the system requirements, this object can reverse the direction of the motor without modifying the motor wiring.

2.2.14 0x200E Internal alarm code

Object Dictionary	Name	Property	Type	Default
0x200E	Alarm Code	R	UINT	0

This object displays the current fault code of the driver, and each bit of the object corresponds to an alarm status.

Alarm code	Alarm status
0x0001	Internal voltage error
0x0002	Overcurrent
0x0004	Overvoltage
0x0008	Reserved
0x0080	Position error is out of tolerance
Other	Reserved

When the above fault occurs, after the fault condition is eliminated, by writing 0x80 in the 0x6040 object, the fault codes of 0x603F and 0x200E will be cleared.

2.2.15 0x200F Internal status code

Object Dictionary	Name	Property	Type	Default
0x200F	Status Code	R	UINT	0

This object displays the current status code of the driver, and each bit of the object corresponds to a status.

Status code	Status
0x0001	Driver enables
0x0002	Driver has failed
0x0004	In place signal
0x0008	Motor running or stopped
0x0010	Homing completed or not
0x0020	Driver ready
其他	Reserved

2.2.16 0x2010 Position cleared

Object Dictionary	Name	Property	Type	Scope	Default	Unit
0x2010	Zero Position	R/W	UINT	0~1	0	---

Setting the object to 01h can clear the position value (position actual value) in 0x6064.

It is usually used when the motor is always moving in one direction. The user needs to stop the motor at an appropriate time, clear the actual position value through this object, and then enable the motor again. Otherwise, the motor position counter will be saturated.

2.2.17 0x2011 Control mode

Object Dictionary	Name	Property	Type	Scope	Default	Unit
0x2011	Control mode	R/W/S	UINT	0~2	0	---

Set the working mode of the stepper motor.

0—— open loop

1—— closed loop

2—— closed loop / FOC mode

ECR60 can only work in open loop mode, setting other values is invalid.

2.2.18 0x2020~0x2026 Reserved

0x2020~0x2026 are reserved for compatible closed-loop driver parameter settings, and users are forbidden to set these parameters.

2.2.19 0x2043 Speed given

Object Dictionary	Name	Property	Type	Scope	Default	Unit
0x2043	Speed Reference	R	UINT	-3000~3000	0	RPM

This object reflects the given speed of the current motor.

2.2.20 0x2044 Speed feedback

Object Dictionary	Name	Property	Type	Scope	Default	Unit
0x2044	Speed Feedback	R	UINT	-3000~3000	0	RPM

This object reflects the actual speed of the current motor. Since the ECR series stepper driver has no position feedback information, the system believes that the motor is not locked at this time, and this object returns the estimated motor speed reference.

2.2.21 0x2048 Voltage

Object Dictionary	Name	Property	Type	Scope	Default	Unit
0x2048	Bus Voltage	R	UINT	---	0	10mV

bus voltage value (V)= object value/100;

2.2.22 0x2049 Input level

Object Dictionary	Name	Property	Type	Scope	Default	Unit
0x2049	Input Level	R	UINT	---	0	---

Display the physical level of the current IO input.

Bit15~bit6	Bit5	Bit4	Bit3	Bit2	Bit1	Bit0
---	IN6	IN5	IN4	IN3	IN2	IN1

0—— No input signal

1—— Input signal

2.2.23 0x204A Output level

Object Dictionary	Name	Property	Type	Scope	Default	Unit
0x204A	Output Level	R	UINT	---	0	---

Displays the physical level of the current output port.

Bit15~bit2	Bit1	Bit0
---	OUT2	OUT1

0— Indicates that the current output port has an output

1— Indicates that the current output port has no output

2.2.24 0x2060 Harmonic amplitude of the first resonance point

Object Dictionary	Name	Property	Type	Scope	Default	Unit
0x2060	Amplitude of First Anti-Vibration	R/W/S	UINT	0-1000	0	---

Used to eliminate the vibration of the first resonance point of the two-phase stepper motor. This method offsets resonance by adding a certain harmonic to the set current. The amplitude and phase of the harmonics need to be adjusted to eliminate vibration.

2.2.25 0x2061 First resonance point A phase harmonic phase

Object Dictionary	Name	Property	Type	Scope	Default	Unit
0x2061	Phase A of First Anti-Vibration	R/W/S	UINT	0-1024	0	---

Adjust the harmonic phase of phase A winding

2.2.26 0x2062 First resonance point B phase harmonic phase

Object Dictionary	Name	Property	Type	Scope	Default	Unit
0x2062	Phase B of First Anti-Vibration	R	UINT	0-1024	0	---

Adjust the harmonic phase of phase B winding

2.3 CIA402 Object dictionary

2.3.1 0x603F Fault code

Object Dictionary	Name	Property	Type	Scope	Default
0x603F	Error Code	RW	UINT		0

When a fault occurs, first eliminate the fault condition, then write 0x0080 to the control word 0x6040 and clear 0x603F.

The fault code is as follows:

Error Code	Description
0x7500	Communication fail
0x3150	Phase A circuit internal voltage error
0x3151	Phase B circuit internal voltage error
0x8611	Closed-loop mode tracking error over limit
0x2211	Overcurrent
0x3110	Overvoltage

2.3.2 0x6040 Control words

This object is used to control the state of the drive and movement. Can enable/disable the drive; start and stop the motor; clear faults, etc.

Object Dictionary	Name	Property	Type	Scope	Default
0x6040	Control Word	RW	UINT		0

The bits of the control word are defined as follows:

Bit	Description
0	Switch ON
1	Enable Voltage
2	Quick Stop
3	Enable Operation
4	Operation mode related
5	Operation mode related

6	Operation mode related
7	Fault reset
8	Pause
9	Operation mode related
10-15	Reserved

Detailed description of the combination of Bit 0~3 and Bit7:

Command	Control word bit				
	Bit7	Bit3	Bit2	Bit1	Bit0
Shutdown	0	x	1	1	0
Switch on	0	0	1	1	1
Switch on + Enable operation	0	1	1	1	1
Disable voltage	0	x	x	0	x
Quick stop	0	x	0	1	x
Disable Operation	0	0	1	1	1
Enable Operation	0	1	1	1	1
Fault reset	0->1	x	x	x	x

Definition of Bit4、 5、 6、 8、 9 in related modes

PP mode

Bit	Name	Value	Description
4	A new target location	0->1	Change from 0 to 1, set a new target position
5	Reserved		
6	Absolute/relative	0	Absolute position mode
		1	Relative position mode
8	Pause	0	The motor is waiting to be positioned
		1	Stop running
9	Reserved		

PV mode

Bit	Name	Value	Description
8	Pause/run	0	The motor runs to the set speed
		1	The motor decelerates to 0 and stops

Homing mode

Bit	Name	Value	Description
4	Start to Home	0->1	Start to Home
8	Pause	0	Controlled by bit4
		1	Stop homing

2.3.3 0x6041 Status word

This object sets the probe function.

Object Type	Data Type	Access Type	PDO Mapping	Default Value
VAR	UNSIGNED16	RW	Yes	0

The register bits are defined as follows:

Bit	Description
0	Ready To Switch ON
1	Switch ON
2	Operation Enabled
3	Fault
4	Voltage Enabled
5	Quick Stop
6	Switch On Disabled
7	Warning
8	Reserved
9	Remote
10	Target arrival
11-15	Reserved

Bit 9: Remote, This bit indicates whether the Control word has been settled.

2.3.4 0x6060 Operation mode

Used to set the operation mode.

Object Dictionary	Name	Property	Type	Scope	Default
0x6060	Mode of Operation	RW	INTEGER8		0

EC series drivers support the following operating modes:

Value	Mode
1	Profile Position Mode (PP)
3	Profile Velocity Mode (PV)
6	Homing Mode (HM)
8	Cyclic Synchronous Position Mode (CSP)

2.3.5 0x6061 Operation mode display

Display the current operating mode, the definition is the same as 0x6060.

Object Dictionary	Name	Property	Type	Scope	Default
0x6061	Mode of Operation Display	R	INTEGER8		0

2.3.6 0x6064 Actual position

Display the actual position of the current motor, the unit is Pulse.

Object Dictionary	Name	Property	Type	Scope	Default
0x6064	Position Actual Value	R	INTEGER32		0

2.3.7 0x606C Actual speed

Display the actual speed of the current motor. The unit is RPM

Object Dictionary	Name	Property	Type	Scope	Default
0x606C	Position Actual Velocity	R	UNIT		0

2.3.8 0x607A Target location

This object sets the target position in PP mode and CSP mode. Unit is Pulse.

Object Dictionary	Name	Property	Type	Scope	Default
0x607A	Profile Target Position	RW	INTEGER32		0

In PP mode, Bit6(0x6040.6) of the control word is used to set the coordinates to be relative.

In CSP mode, the target position is absolute position mode.

2.3.9 0x607C Home offset

This object is used to set the offset of the home sensor and position 0. Unit is Pulse.

Object	Name	Property	Type	Scope	Default
--------	------	----------	------	-------	---------

Dictionary	Name	Property	Type	Scope	Default
0x607C	Home Offset	RW	INTEGER32		0

2.3.10 0x6081 Track speed

This object is used to set the maximum speed of the trapezoidal acceleration/deceleration command in PP mode. Unit is Pulse/s.

Object Dictionary	Name	Property	Type	Scope	Default
0x6081	Profile Velocity	RW	INTEGER32		10000

2.3.11 0x6083 Track acceleration

This object is used to set the acceleration of the trapezoidal acceleration/deceleration command in PP mode and PV mode, the unit is Pulse/s².

Object Dictionary	Name	Property	Type	Scope	Default
0x6083	Profile Acceleration	RW	INTEGER32		100000

2.3.12 0x6084 Track deceleration

This object is used to set the deceleration of the trapezoidal acceleration/deceleration command in PP mode and PV mode, the unit is Pulse/s².

Object Dictionary	Name	Property	Type	Scope	Default
0x6084	Profile Deceleration	RW	INTEGER32		100000

2.3.13 0x6085 Quickstop declaration

This object is used to set the deceleration of the motor when it hits the limit, home and other sensors in PP mode, PV mode, and HOME mode. Unit is Pulse/s.

Object Dictionary	Name	Property	Type	Scope	Default
0x6085	Quickstop Declaration	RW	INTEGER32		500000

2.3.14 0x6098 Homing method

This object is used to set the homing method for the motor.

Object Dictionary	Name	Property	Type	Scope	Default
0x6098	Homing Method	RW	INTEGER8	17~35	17

For detailed description, please refer to homing mode.

2.3.15 0x6099 Homing speed

This object sets the motor speed when in homing mode.

Object Dictionary	Name	Property	Type	Scope	Default	Unit
0x6099:01	Homing Velocity (fast)	R/W/S	UNSIGNED32	---	10000	Pulse/s
0x6099:02	Homing Velocity (slow)	R/W/S	UNSIGNED32	---	2000	Pulse/s

2.3.16 0x609A Homing acceleration

This object is used to set the acceleration and deceleration of the position curve when in homing mode. The unit is Pulse/s².

Object Dictionary	Name	Property	Type	Scope	Default
0x609A	Homing Acceleration	RW	UNSIGNED32		100000

2.3.17 0x60B8 Probe function setting

This object sets the probe function.

Object Type	Data Type	Access Type	PDO Mapping	Default Value
VAR	UNSIGNED16	RW	Yes	0

The register bits are defined as follows:

Bit	Value	Definition
0	0	Probe 1 disabled
	1	Probe 1 enable
1		Reserved
2		Reserved
3		Reserved
4	0	Disable probe 1 falling edge latch
	1	Enable probe 1 rising edge latch
5	0	Disable probe 1 falling edge latch
	1	Enable probe 1 falling edge latch
6		Reserved
7		Reserved
8	0	Probe 2 disabled
	1	Probe 2 enable

9		Reserved
10		Reserved
11		Reserved
12	0	Disable probe 2 falling edge latch
	1	Enable probe 2 rising edge latch
13	0	Disable probe 2 falling edge latch
	1	Enable probe 2 falling edge latch
14		Reserved
15		Reserved

The positive position is latched at the rising edge, and the negative position is latched at the falling edge.

2.3.18 0x60B9 Probe status

This object defines the status of the probe function.

Object Type	Data Type	Access Type	PDO Mapping	Default Value
VAR	UNSIGNED16	R	Yes	0

The status bits are defined as follows:

Bit	Value	Definition
0	0	Probe 1 disabled
	1	Probe 1 enable
1	0	Probe 1 rising edge latch: none
	1	Probe 1 rising edge latch: yes
2	0	Probe 1 falling edge latch: none
	1	Probe 1 falling edge latch: yes
3-7	0	Reserved
8	0	Probe 2 disabled
	1	Probe 2 enable
9	0	Probe 2 rising edge latch: none
	1	Probe 2 rising edge latch: yes
10	0	Probe 2 falling edge latch: none
	1	Probe 2 falling edge latch: yes
11-15	0	Reserved

2.3.19 0x60BA Probe 1 positive latch value

This object holds the position latched by the rising edge of probe 1.

Object Type	Data Type	Access Type	PDO Mapping	Default Value
VAR	UNSIGNED32	R	Yes	0

2.3.20 0x60BB Probe 1 negative latch value

This object holds the position latched by the falling edge of probe 1.

Object Type	Data Type	Access Type	PDO Mapping	Default Value
VAR	UNSIGNED32	R	Yes	0

2.3.21 0x60BC Probe 2 positive latch value

This object holds the position latched by the rising edge of probe 2.

Object Type	Data Type	Access Type	PDO Mapping	Default Value
VAR	UNSIGNED32	R	Yes	0

2.3.22 0x60BD Probe 2 negative latch value

This object holds the position latched by the falling edge of probe 2.

Object Type	Data Type	Access Type	PDO Mapping	Default Value
VAR	UNSIGNED32	R	Yes	0

2.3.23 0x60FD Digital Inputs

This object monitors the input port of the driver.

Object Type	Data Type	Access Type	PDO Mapping	Default Value
VAR	UNSIGNED32	RO	Yes	0x00000000

Bit0	CW limit	0—Invalid 1—Limit take effect
Bit1	CCW limit	
Bit2	HOME	0—HOME invalid 1—HOME invalid
Bit3~ Bit15	Reserved	
Bit16	IN1	Physical state of input port 0 — Input signal is invalid 1 — Input signal is valid
Bit17	IN2	
Bit18	IN3	
Bit19	IN4	
Bit20	IN5	
Bit21	IN6	
Bit22~Bit31	Reserved	

2.3.24 0x60FF PV mode speed setting

This object sets the speed in PV mode, the unit is Pulse/s.

Object Dictionary	Name	Property	Type	Scope	Default	Unit
0x60FF	Target Velocity	RW	DINT		0	Pulse/s

This object is 32-bit signed data, and the positive and negative values respectively represent the two directions of motor operation.

2.3.25 0x6502 Operation mode supported

This object describes the operation mode supported by the driver.

Object Dictionary	Name	Property	Type	Scope	Default	Unit
0x6052	Supported Drive Modes	R	UDINT		0x000000A5(165)	---

The bits are defined as follows:

Bit	Description
0	PP: Profile Position Mode
1	VI: Velocity Mode
2	PV: Profile Velocity Mode
3	TQ: Torque Profile Mode
4	reserved
5	HM: Homing Mode
6	IP: Interpolated Position Mode
7	CSP: Cyclic Sync Position Mode
8	CSV: Cyclic Sync Velocity Mode
9	Cyclic Sync Torque Mode
10-31	reserved

Bit value = 0: Not support

Bit value = 1: Support

EC series stepper drivers support PP, PV, HM, CSP modes.

2. 4 **CIA402 Motion control**

2.4.1 **Operation mode**

ECR series EtherCAT stepper driver supports the following operation modes (0x6060):

Profile Position (PP)

Profile Velocity (PV)

Cyclic Synchronous Position (CSP)

Homing (HM)

2.4.2 **PP Profile Position Mode**

Profile position mode description:

Standard position mode is a point-to-point operation mode that uses a set point composed of speed, acceleration, deceleration and target position. Once all these parameters are set, the driver will buffer these commands and start executing the set point.

Enable PP mode

To enable the profile position mode, the value of the object dictionary 6060h (operation mode) must be set to 0001h. The object dictionary 6061h (operation mode display) can be used to confirm whether the driver has entered the correct operation mode.

Set operating parameters

Use object dictionary 607Ah, 6081h, 6083h, 6084h to set position, velocity, acceleration, deceleration respectively.

Start and stop

After power on, the driver is in the disabled state. Writing 0006h into the control word 6040h will make the drive enter the "ready to switch on" state.

By sending 001Fh to the object dictionary 6040h of the control word, to indicate a new set point and start movement.

To enable the operation of the driver, the value 001Fh must be written into the object dictionary address 6040h of the control word. This also means that a new set point is ready. The driver uses Bit12 of the status word (6041h) to indicate that a valid setpoint is received. Because the

set point is edge triggered, once the driver receives and processes the set point, the control word must be cleared by writing 000FH to the control word register.

Controlword Bits

New set point (bit 4) - set this bit high to clock in a new set-point. Once the driver receives the set point, Bit12 of the status word will be set to high (1), and bit4 of the control word needs to be set to 0;

Setpoint Change (bit 9) - If it is low, the driver enters an idle state after executing the current setpoint and waits for the next new setpoint. If it is high, the driver will run to the last set point at the last set speed, then switch to the new speed and run to the new set point.

Setpoint takes effect immediately (bit 5) - If this bit is high, the new setpoint takes effect immediately and the motor will run to the new position at the speed of the new setpoint.

Absolute mode/relative mode (bit 6)-If it is high, the set point is in relative position mode. For example, if the previous motor position is 10,000 steps, and the new set point is 20,000, the final position will be 30,000. If it is low, the set point is in absolute position mode. If the previous motor position is 10000 and the new set position is 20000, then the new position will be 20000. (The distance from the previous position to the new position is 10,000 steps). Do not change this position when the motor is moving.

2.4.3 PV Profile Velocity Mode

Profile velocity mode description

The profile velocity is a relatively simple mode of operation. Once the speed, acceleration and deceleration are set, the driver will command the motor to accelerate to the running speed according to the acceleration parameter, or stop the movement according to the deceleration parameter.

The figure below shows an example of configuring the speed mode.

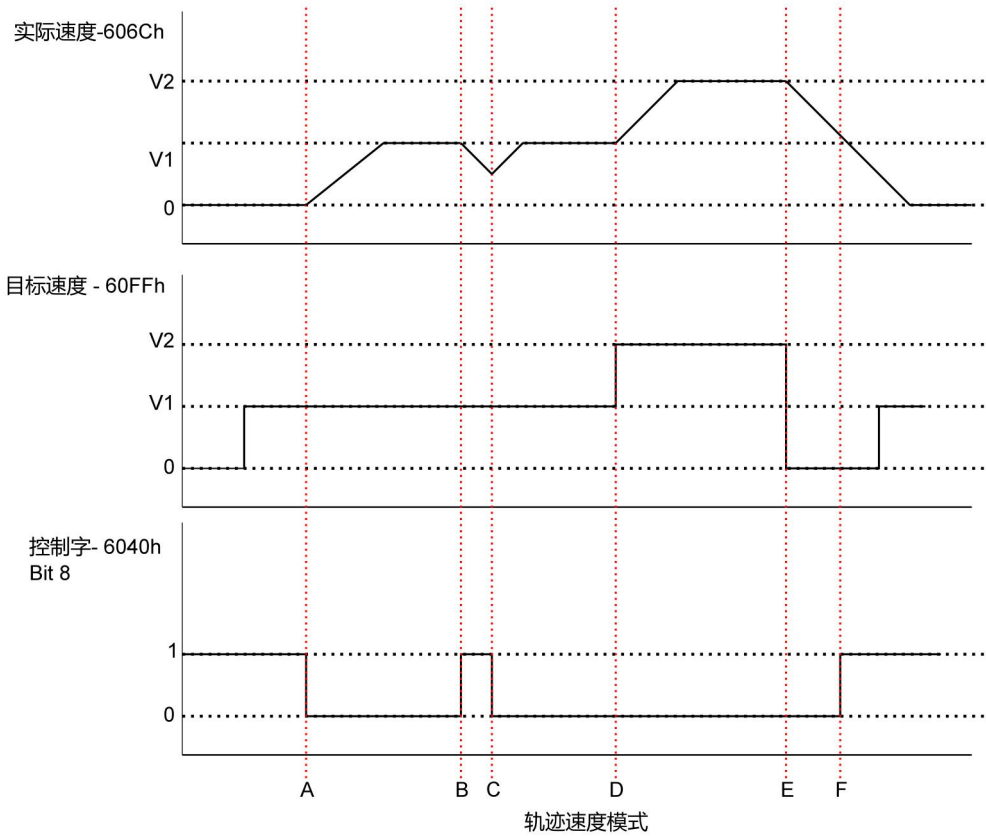

The above figure shows the corresponding relationship between the motor running status, actual speed, target speed and control word.

	Target speed	6040h stop bit Bit4	Motor movement status
Start	0	1	Motor stop
A	V1	1 -> 0	Motor accelerates to V1
B	V1	0 -> 1	Motor decelerates to stop
C	V1	1 -> 0	Before the motor stopped, it accelerated to V1.
D	V1 -> V2	0	Motor accelerates from V1 to V2
E	V2 -> 0	0	Motor decelerates from V2 to 0
F	0	0 -> 1	Motor stop
G	0 -> V1	1	Motor stop

The table above explains how the stop bit and the target speed are used together to affect motor speed. Between points B and C, the motor does not come to a complete stop, but decelerates according to the trajectory deceleration value that begins at point B. When the stop bit switches at point C, it immediately accelerates back to the target speed. At point E, reducing the target speed to zero has the same effect as using the stop bit.

It should be noted that no matter if the stop bit is set and the target speed is set to zero, a torque

will be maintained on the motor. If you want the axis to move freely, the driver must be placed in the driver disabled (disabled) status.

Enable PV mode

To enable the profile velocity mode, the value of object dictionary 6060h (operation mode) must be set to 0003h. The object dictionary 6061h (operation mode display) can be used to confirm whether the driver has entered the correct operation mode.

Set operating parameters

Use object dictionary 60FFh, 6083h, 6084h to set the speed, acceleration and deceleration of the profile velocity mode respectively.

Enable driver

After power on, the driver is in the disabled state. Writing 0006h into the control word 6040h will make the driver enter the "ready to switch on" state. Write 010Fh into 6040h to make the driver enter the "Operation Enabled" state, and the motor is stopped.

Start and stop

To start and stop the movement, switch the control word stop bit (bit 8). When the stop bit is set to 0 (000Fh), the movement will start or continue; when the stop bit is set to 1 (010Fh), the movement will stop.

Profile velocity (60FFh) more than zero means the motor is running forward, less than zero means the motor is reversing, and equal to zero means the motor is stopped. Users can directly set the motor to enter the reverse state when the motor is running forward, and the motor will decelerate to stop and accelerate to the set speed in the reverse direction.

2.4.4 CSP Cyclic Sync Position Mode

Cyclic sync position mode description

In this mode, the main controller generates a position trajectory and sends the target position (0x607A) to the driver in each PDO update cycle. The driver feedbacks the actual motor position and optional actual motor speed and torque.

Enable CSP mode

To enable the cyclic synchronization position mode, the value 0008h must be written to the dictionary address 6060 h.

Enable driver

After power on, the drive is in the disabled state. Writing 0006h into the control word 6040h will make the drive enter the "ready to switch on" state. Write the value 0x000F to 6040h again, the drive will be in the enabled state, and the motor can respond to the CSP command.

2.4.5 Probe function

The probe function latches the motor position information through the digital input port.

ECR60's digital input port function and polarity can be defined by 0x2007, 0x2008.

The relevant object dictionary of the probe function is as follows:

Index	Object description	
0x60B8	探针功能设置	Touch Probe Function
0x60B9	探针状态	Touch Probe Status
0x60BA	探针 1 上升沿锁存位置	Touch Probe Position 1 Positive Value
0x60BB	探针 1 下降沿锁存位置	Touch Probe Position 1 Negative Value
0x60BC	探针 2 上升沿锁存位置	Touch Probe Position 2 Positive Value
0x60BD	探针 2 下降沿锁存位置	Touch Probe Position 2 Negative Value

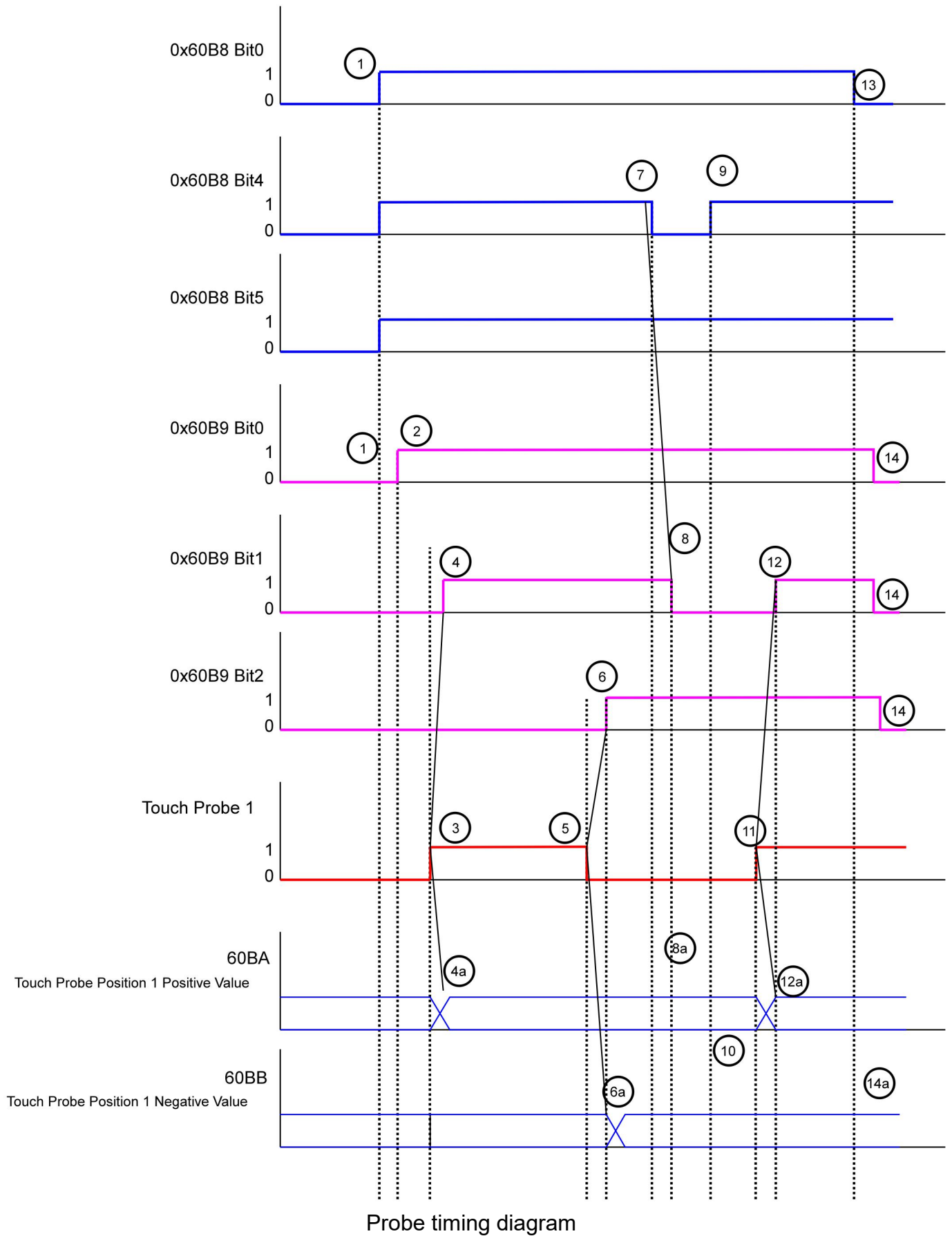

Serial No.	Change of registers	Probe action
1	60B8 Bit 0 = 1 60B8 Bit 1,4,5	Enable probe 1 Configure the rising edge and falling edge of the enable probe
2	-> 60B9 Bit 0 = 1	The state "probe 1 enabled" is set
3		External probe signal rising edge
4	-> 60B9 Bit 1 = 1	The state "Probe 1 rising edge latch" is set
4a	-> 60BA	The positive position of probe 1 is latched
5		External probe signal falling edge
6	-> 60B9 Bit 2 = 1	The state "Probe 1 falling edge latch" is set
6a	-> 60BB	The negative position of probe 1 is latched
7	-> 60B8 Bit: 4	Rising edge latch function: disabled
8	-> 60B9 Bit 0 = 0	The state "Probe 1 rising edge latch" is cleared
8a	-> 60BA	Probe 1 positive position, the latch position remains unchanged
9	-> 60B8 Bit 4 = 1	Rising edge latch function: enable
10	-> 60BA	Probe 1 positive position, the latch position remains unchanged
11		External probe signal rising edge
12	-> 60B9 Bit 1 = 1	The state "Probe 1 rising edge latch" is set
12a	-> 60BA	The positive position of probe 1 is latched
13	-> 60B8 Bit 0 = 0	Probe 1 function: disabled
14	-> 60B9 Bit 0,1,2 = 0	Status bit is cleared
14a	-> 60BA,60BB	No change in the positive/negative latch position of probe 1

Probe timing description

2.4.6 Homing mode

Set homing parameters

Set the homing speed, acceleration, home offset and related sensor input signals.

The relevant object dictionary is as follows:

Object dictionary	Description
0x607C	Home offset
0x6098	Homing method setting
0x6099	Homing speed
0x609A	Homing acceleration
0x2007	Input port function selection
0x2008	Input port polarity setting

Enable Homing mode:

To enable the zero return mode, the value of object dictionary 6060h (operation mode) must be set to 0006h. The object dictionary 6061h (operation mode display) can be used to confirm whether the drive has entered the correct operation mode.

After the drive is initially powered on, it is in the disabled state. Write 6 to the control word 6040h, set the drive to the "ready to switch on" state, then write 000Fh to the control word 6040h, and set the drive to "Operation Enabled Mode".

Active Homing function:

Set the homing method through the 6098h object dictionary.

Set the homing speed through 0x6099.

Through the Bit4 of the control word 6040h, the rising edge from 0 to 1, can start the function of homing. The status of homing is queried through the 6041 status word.

Stop the homing function:

Set the homing method through the 6098h object dictionary. Through the Bit8 of the control

word 6040h, the rising edge from 0 to 1, can stop the function of homing. The status of homing is queried through the 6041 status word.

2. 4. 6. 1 Homing method

The ECR60 driver supports 17~34,35 homing methods. The specific definition and the process of homing are described as follows.

2. 4. 6. 2 Method 17:

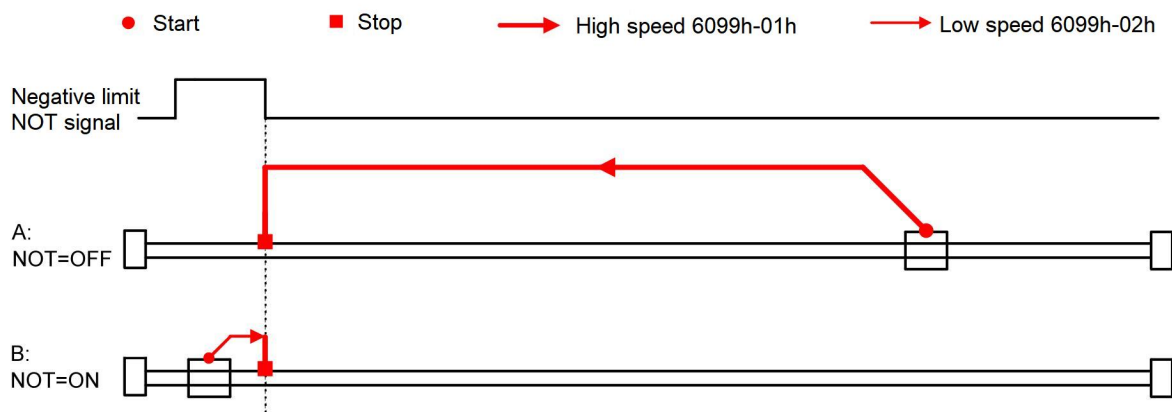

2. 4. 6. 3 Method 18:

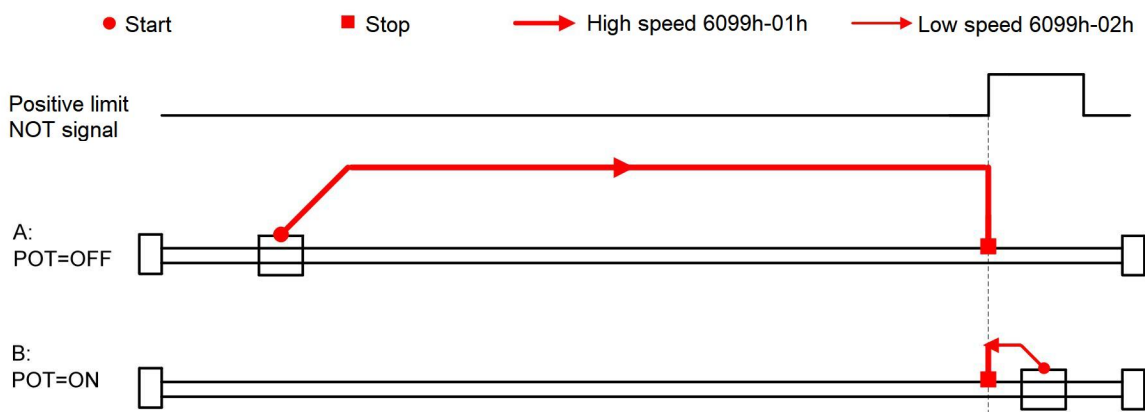

2. 4. 6. 4 Method 19:

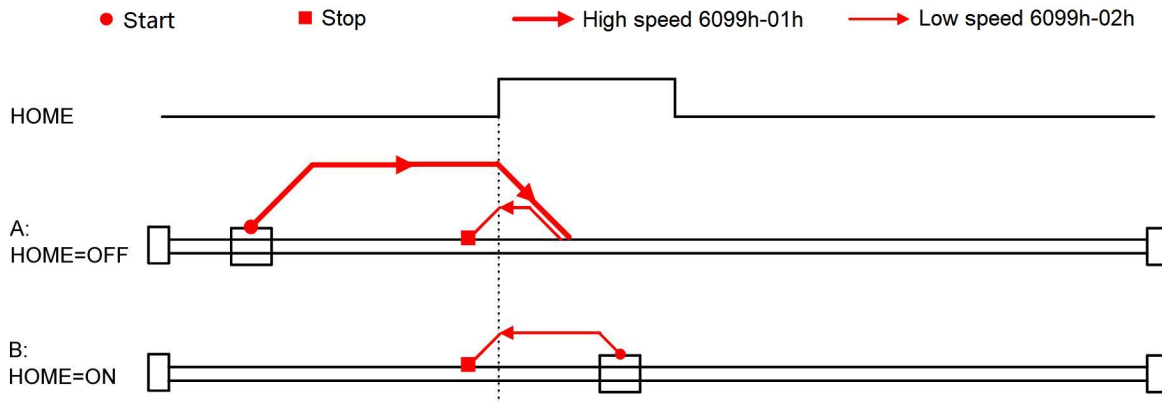

2. 4. 6. 5 Method 20:

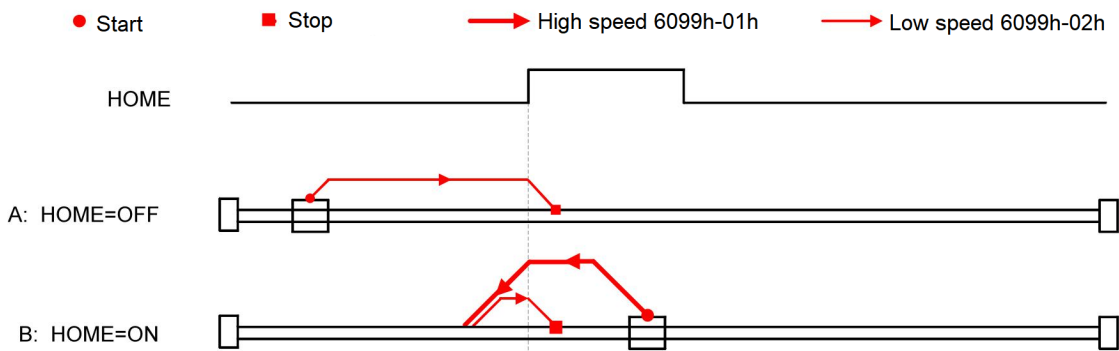

2. 4. 6. 6 Method 21:

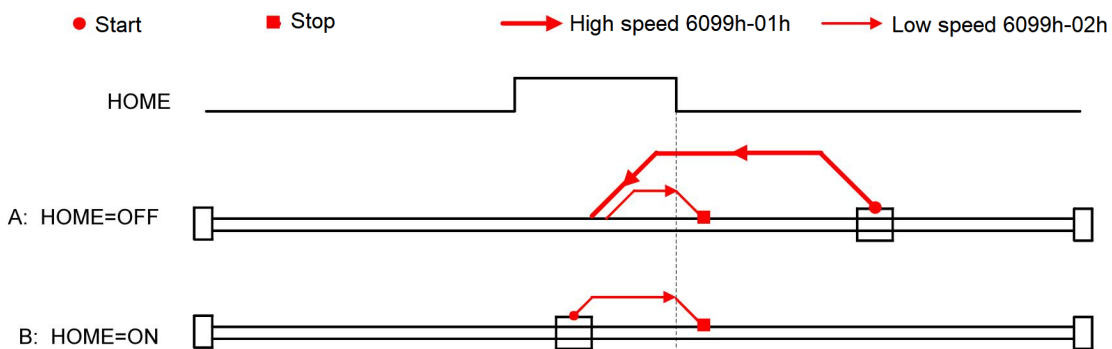

2. 4. 6. 7 Method 22:

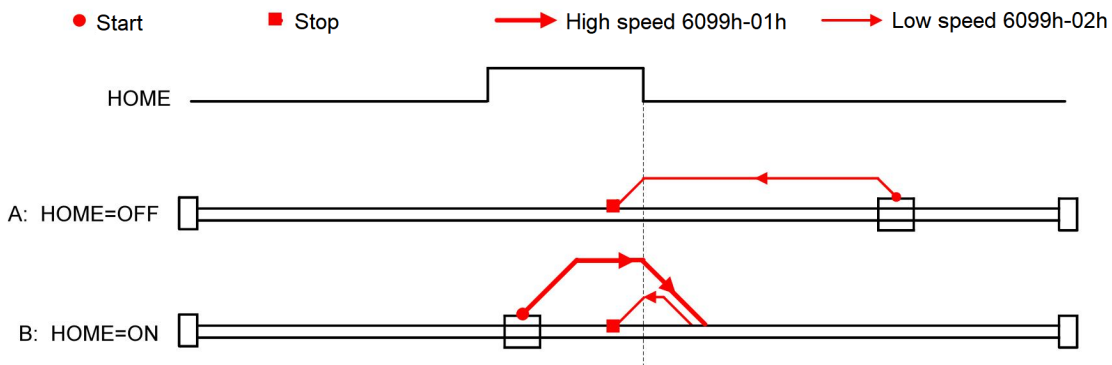

2. 4. 6. 8 Method 23:

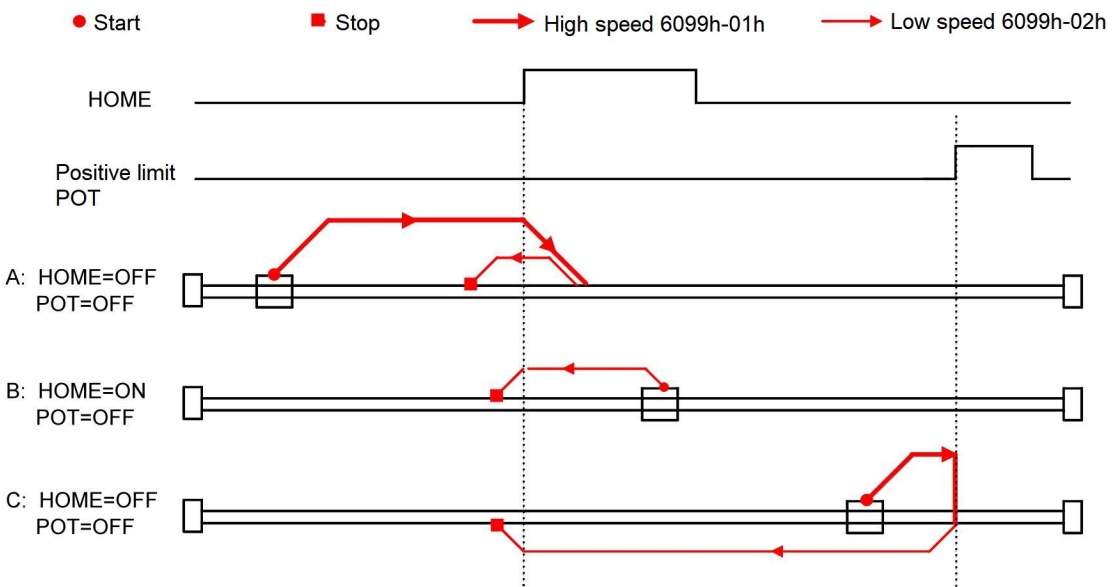

2. 4. 6. 9 Method 24:

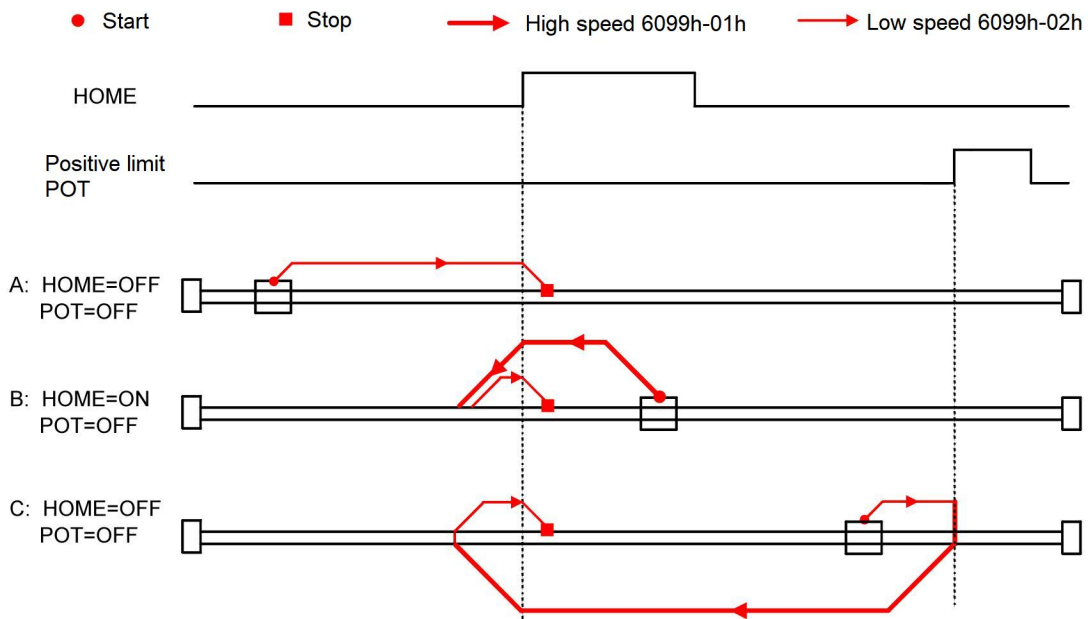

2. 4. 6. 10 Method 25:

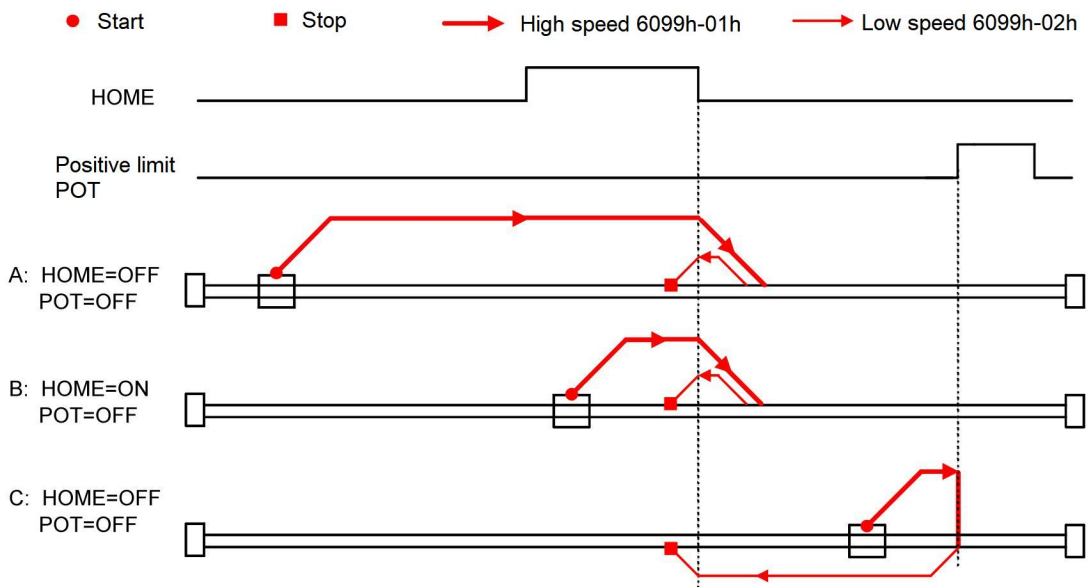

2. 4. 6. 11 Method 26:

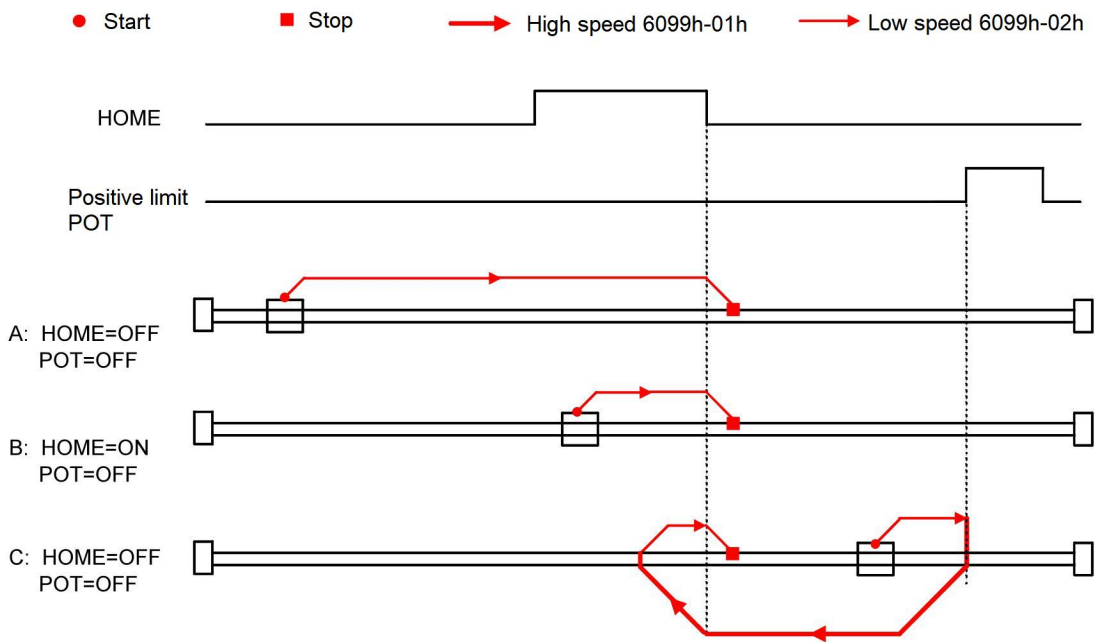

2. 4. 6. 12 Method 27:

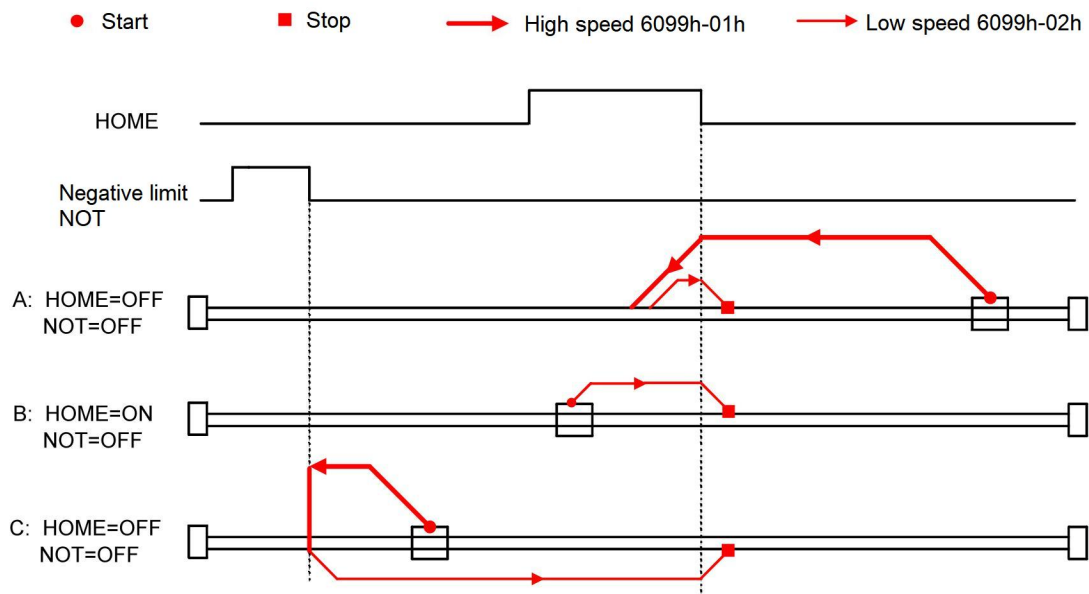

2. 4. 6. 13 Method 28:

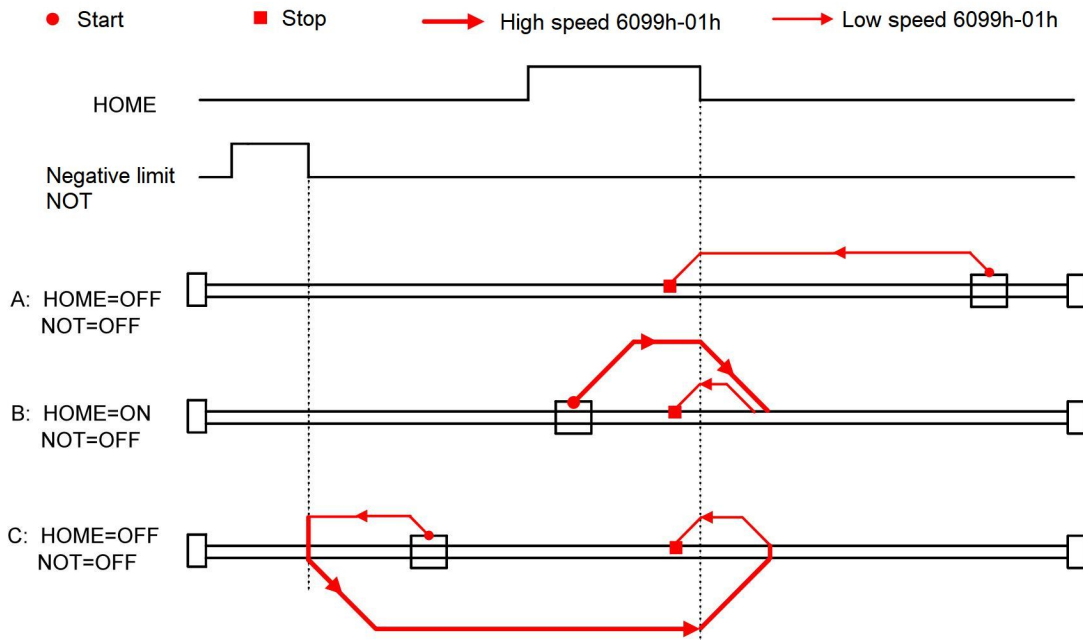

2. 4. 6. 14 Method 29:

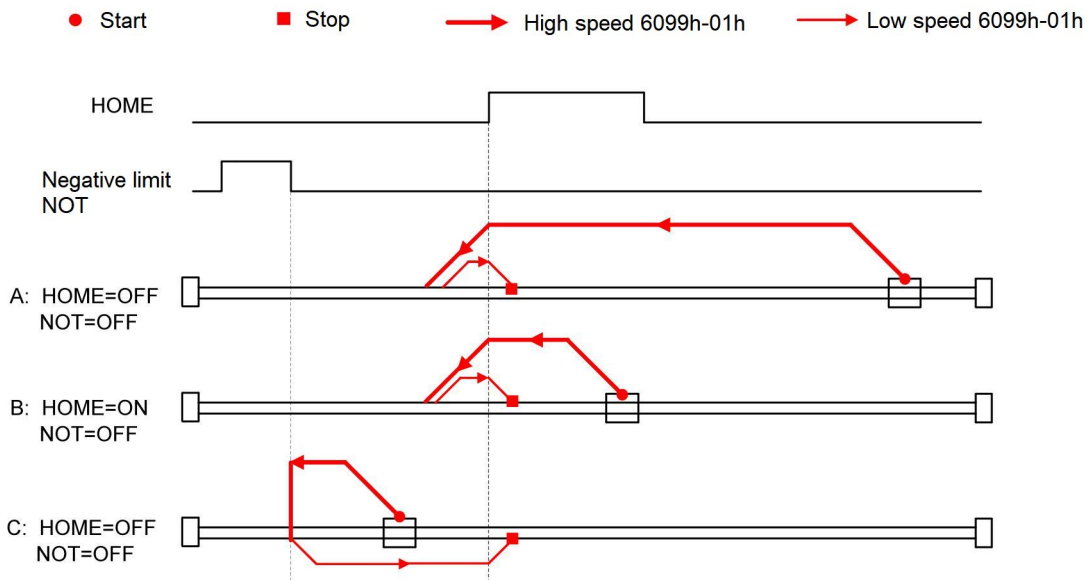

2. 4. 6. 15 Method 30:

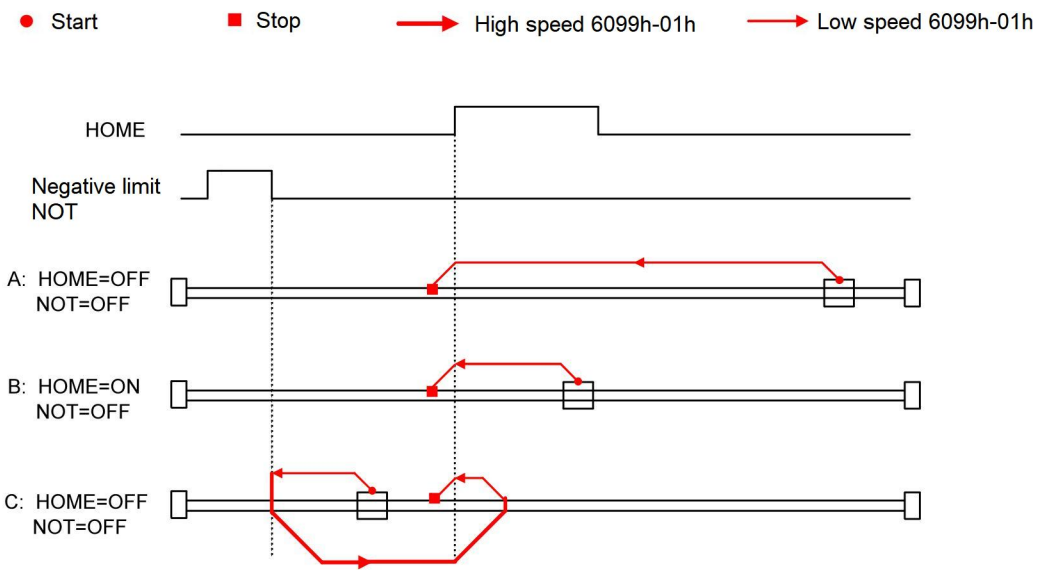

2. 4. 6. 16 Method 35:

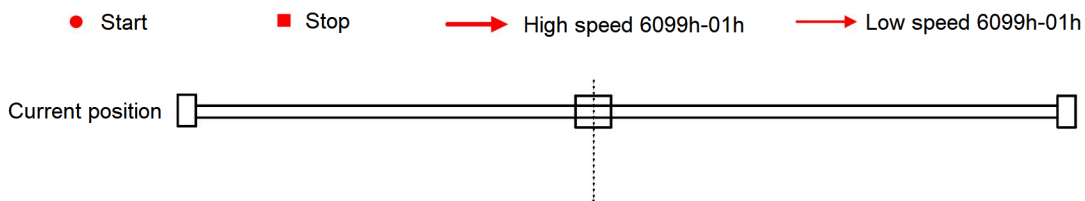

CONTACT RTELLIGENT

Rtelligent Head Office

Add: 3rd floor, Building B, Zhuangbian Industrial Park Nanchang Road, Gushu, Baoan District, Shenzhen, China

Zip code: 201107

Tel: +86 (0)755 29503086

Fax: +86 (0)755 23327086

Email: sales@szruitech.com

Office in East China

Add: Room 328, No. 9, Shiyi Business Building, 5555 Shenzhuan Road, Songjiang District, Shanghai

Contact: Mr. Ruan

Tel: 1811749519

Email: sales03@szruitech.com

Office in Shandong Province

Add: Room 601, Unit 1, Building 22, Xincashi Street, Tianqiao District, Jinan City, Shandong

Contact: Mr. Lu

Tel: 13854109911

Email: sales06@szruitech.com