

SL28110A 2 Phase Hybrid Stepper Drives

Manual

[Please read the user' s manual carefully before using, in order to avoid damage to the drive]



1. Introduction

Overview

SL8110A Drives are high performance digital 2-phase hybrid Stepper Drives newly released by Shenzhen Shenli Witt Motor Co., Ltd. The Drives use PI controller to achieve low heating, low noise, low cost and high stability. The Drives have 16 selectable resolutions and 16 selectable current setting. To improve reliability, the Drives have some built-in protection functions, they alarm when over voltage, under voltage and over current. Optoelectronic isolation is employed to the input control signal

In self-running mode, the running speed could be set by SW5-SW8 switches. External control signals are also used to control the motor motions like stop, start, forward and reverse. The 4-28V signal level is used for protection of pulse, direction and enable. Integrated cooling function is built in to auto cut the current.

Feature

- Use PI control algorithm, low noise, low vibration, low heating, high speed, high torque.
- Signal: differential/single end, impulse/ direction or double impulse, to be set the auto self-running or controlled self-running by the DIP switch. The setting of self-running speed is in the speed table.
- To use ST low fever MOS, the heat is within 25° than ambient temperature in the allowed voltage range.
- Power supply up to AC110V, DC160
- Easy current setting, 16 options, peak current 8.2A;

- The current cut half after stop for one second.
- Compatible with 4, 6 and 8 lead wires motor.
- 16 selectable resolutions , could reach 256 selectable resolutions , could be customized according to the customer requirement before order.
- Optical isolation differential signal input. , frequency up to 300KHz ;
- Prevents damages when overvoltage, under voltage and short circuit. ;

Applications

The drivers are applicable to various large and medium automation equipment and instruments, including engraving machines, labeling machines, cutting machines, numerical control machine tools, and plotters. They are ideal choices for users in search of low vibration, low noise, high accuracy, and high speed.

2. Product Parameters

a) Electrical parameters

Descriptions	SL28110A			
	Min.	Typical	Max	Unit
Output Current (Peak)	2.2	-	8.2	A
Input Voltage	18	80	110	VAC
	18	90	160	VDC
Signal current	5	10	20	mA
Stepper Pulse frequency	0	-	300	KHz
Stepper Pulse width	2	-	-	us
Direction signal width	100	-	-	us
Under-Voltage protection Voltage	-	17.5	-	VDC
Over-Voltage protection Voltage	-	200	-	VDC
Drive initial time	2	-	-	s
Insulation resistance	500			MΩ

Operating Environment

Cooling method		Natural cooling or forced air cooling
Environment	Environment	Avoid the environment with great amount of metallic powder,
	Temperature	0—+50°C
	Humidity	40—90%RH
	vibration	10~55Hz/0.15mm
Storage temperature		-20°C ~ 65°C
Weight		350g

Mechanical Specifications and cooling

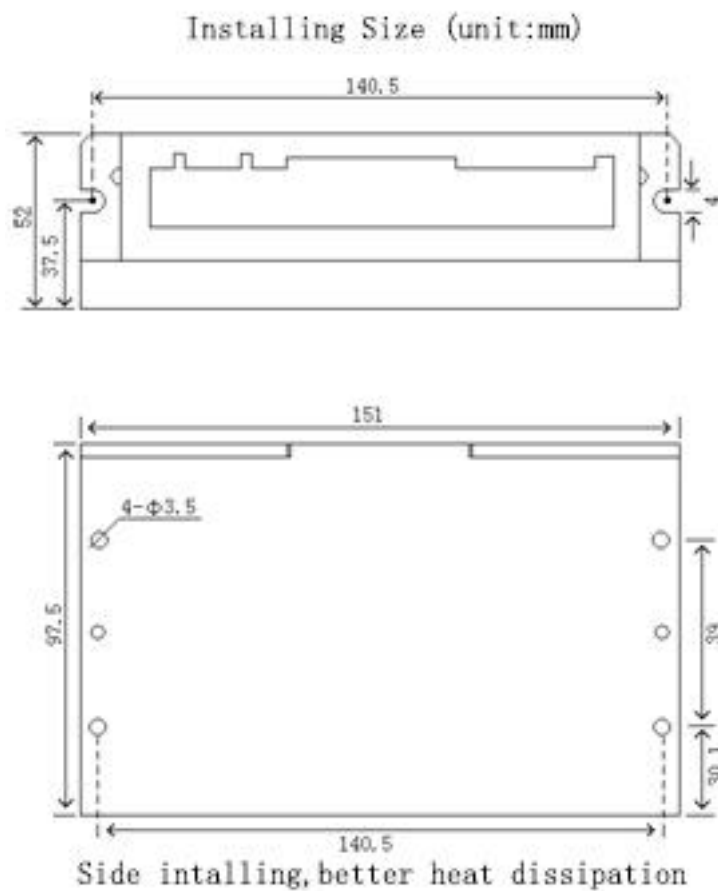

- 1) When mounting, please consider the connectors dimension and cooling space.
- 2) Drive' s reliable working temperature(heat sink) should be $<60^{\circ}\text{C}$, and motor working temperature(surface) should be $<80^{\circ}\text{C}(176^{\circ}\text{F})$;
- 3) It is recommended to mount the driver vertically to maximize heat sink area. Use forced cooling method to cool the system if necessary.

Connectors and wiring

Connector description

1) Control signal connector

Name	functions
PUL+(CCW+)	<u>Pulse signal</u> : In single pulse (pulse/direction) mode, this input represents pulse signal, each rising or falling edge active; input voltage range 3.3~28V. In double pulse mode (pulse/pulse) , this input represents clockwise (CCW) pulse. For reliable response, pulse width should be longer than 1.2 μs .
PUL-(CCW-)	
DIR+(CW+)	<u>DIR signal</u> : In single-pulse mode, this signal has low/high voltage levels, representing two directions of motor rotation; in double-pulse mode (software configurable), this signal is counter-clock (CW) pulse, active both at high level and low level. For reliable motion response, DIR signal should be ahead of PUL signal by 5 μs at least. Please note that rotation direction is also related to motor-drive wiring match. Exchanging the connection of two wires for a coil to the drive will reverse motion direction. Input voltage range 3.3~28V.
DIR-(CW-)	
EN+(ALM+)	<u>Enable signal</u> : This signal is used for enabling/disabling the drive. Low level for disabling the drive. When this function is no need just unconnected the connector. Input voltage range 3.3~28V.
EN-(ALM-)	Alarm function(need to be customized) 1、 When the user do not need enable function, the drive can be used normally, when the user need enable function, please avoid this connection. 2、 Use the connection as the picture as below to enable the alarm function.

2) Power connectors

Name	Functions
AC1	DC power (+) , range +18V—+110V , suggested +80V
AC2	AC power (+) , range +18V—+160V , suggested +90V
A+、 A-	Motor winding A
B+、 B-	Motor winding B

1. Connecting Control Signal

Differential circuit is used in SL28110A to achieve Differential signal output, common anode and cathode connector are used :

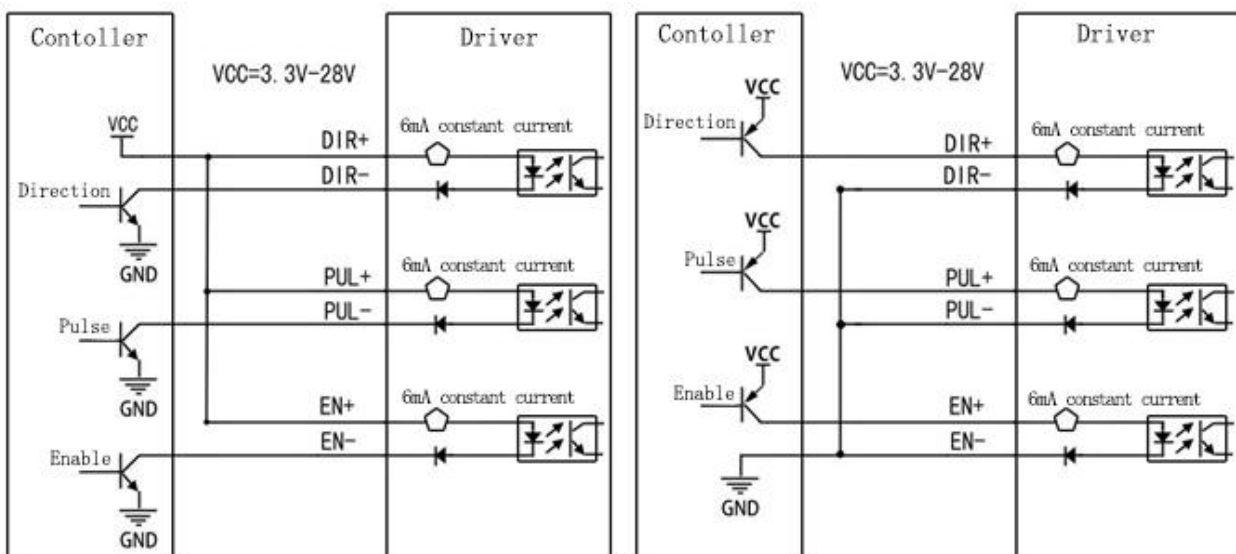

2. Wiring requirement

In order to improve anti-interference performance of the Driver, it is recommended to use twisted pair shield cable. To prevent noise incurred in PUL/DIR signal, pulse/direction signal wires and motor wires should not be tied up together. It is better to separate them by at least 10 cm, otherwise the disturbing signals generated by motor will easily disturb pulse direction signals, causing motor position error, system instability and other failures. If a power supply serves several Drivers, separately connecting the Drivers is recommended instead of daisy-chaining. It is prohibited to pull and plug connector P2 while the Driver is powered ON, because there is high current flowing through motor coils (even when motor is at standstill). Pulling or plugging connector P2 with power on will cause extremely high back-EMF voltage surge, which may damage the Driver.

Current and resolution setting.

SL28110A uses an 10 DIP switch to set microstep resolution, and motor operating current, as shown below:

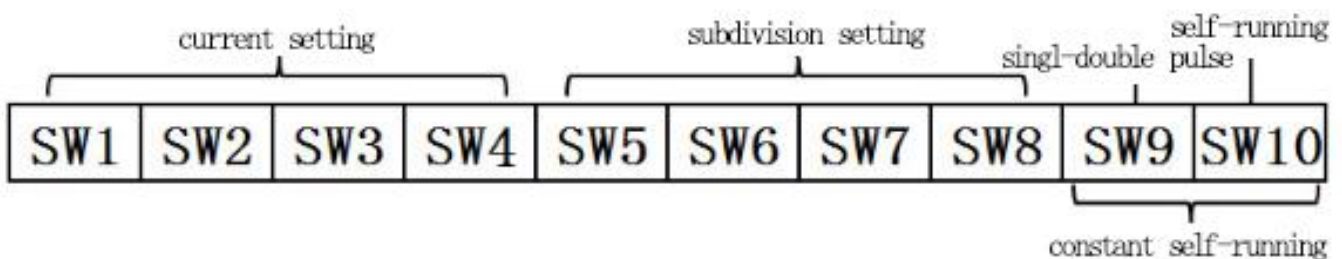

1. Single pulse setting

Running mode	SW9	SW10
Single pulse	OFF	OFF
Double pulse	ON	OFF
Controlled auto-running	OFF	ON
Continued auto-running	ON	ON

Current and resolution setting.

Peak current	SW1	SW2	SW3	SW4
8.2A	ON	ON	ON	ON
7.8A	OFF	ON	ON	ON
7.4A	ON	OFF	ON	ON
7.0A	OFF	OFF	ON	ON
6.6A	ON	ON	OFF	ON
6.2A	OFF	ON	OFF	ON
5.8A	ON	OFF	OFF	ON
5.4A	OFF	OFF	OFF	ON
5.0A	ON	ON	ON	OFF
4.6A	OFF	ON	ON	OFF
4.2A	ON	OFF	ON	OFF
3.8A	OFF	OFF	ON	OFF
3.4A	ON	ON	OFF	OFF
3.0A	OFF	ON	OFF	OFF
2.6A	ON	OFF	OFF	OFF
2.2A	OFF	OFF	OFF	OFF

Step/rev	SPD	SW5	SW6	SW7	SW8
400	5	ON	ON	ON	ON
800	10	OFF	ON	ON	ON
1600	15	ON	OFF	ON	ON
3200	20	OFF	OFF	ON	ON
6400	30	ON	ON	OFF	ON
12800	45	OFF	ON	OFF	ON
25600	60	ON	OFF	OFF	ON
51200	90	OFF	OFF	OFF	ON
1000	120	ON	ON	ON	OFF
2000	150	OFF	ON	ON	OFF
4000	180	ON	OFF	ON	OFF
5000	210	OFF	OFF	ON	OFF
8000	240	ON	ON	OFF	OFF
10000	270	OFF	ON	OFF	OFF
20000	300	ON	OFF	OFF	OFF
40000	360	OFF	OFF	OFF	OFF

2. Static current setting

The current will be cut half after the pulse signal stop for 1 second, this can lower down the heating for 25%.

Motor connection

SL28110A can drive any 4, 6, 8 wires 2 phase and 4 phase hybrid stepper motors.

Selecting motors

Wiring diagram

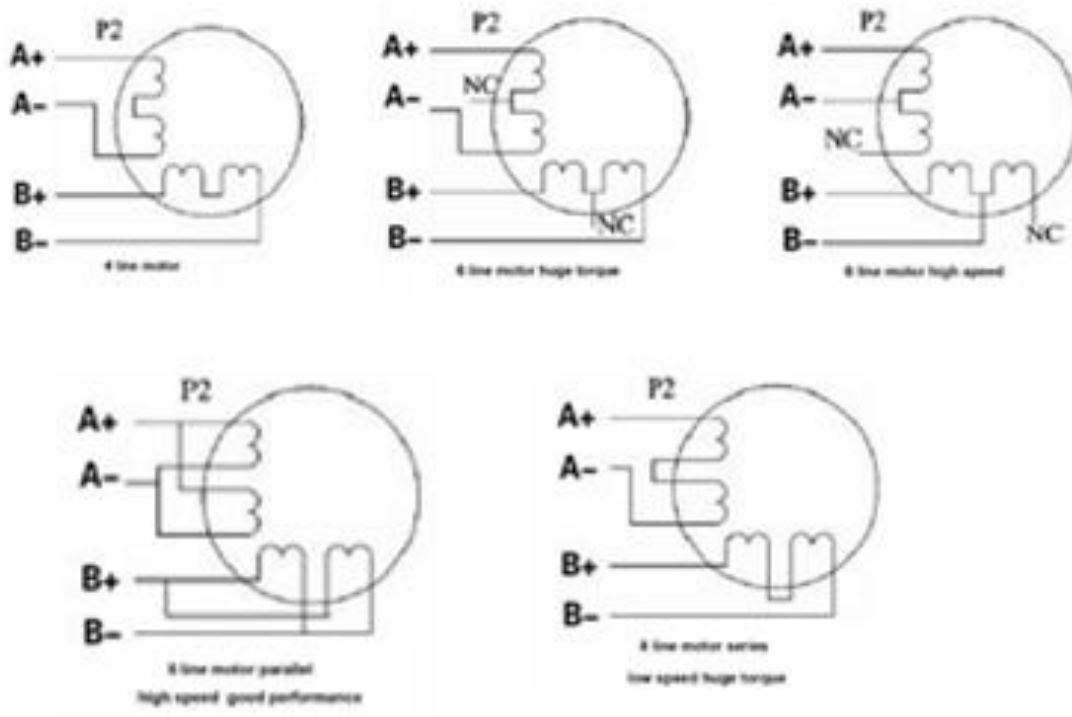

SL8110A can drive any 2-phase and 4-phase hybrid stepping motors.

Selecting Supply Voltage and current

Selecting Supply Voltage

The power MOSFETS inside the SL28110A drive can actually operate with wider voltage range than the input specification. Higher supply voltage can increase motor torque at

higher speeds, thus helpful for avoiding losing steps. However, higher voltage may cause bigger motor vibration at lower speed, and it may also cause over-voltage protection or even drive damage. Therefore, it is suggested to choose only sufficiently high supply voltage for intended applications, and it is suggested to use power supplies with theoretical output voltage of drive' s minimum + 10% to drive' s maximum – 10%, leaving room for power fluctuation and back-EMF.

Setting the output current

For the same motor, if set the current higher, the torque will be higher too. but at the same time it causes more heating in the motor and Drive. Therefore, output current is generally set to be such that the motor will not overheat for long time operation. It is therefore important to set Drive output current depending on motor phase current, motor leads and connection methods. Phase current rating supplied by motor manufacturer is important in selecting Driver current, however the selection also depends on leads and connections. The setting methods suggest below if for your reference. In general, if the temperature of the drive is low (<40°C), then increase the current to improve the output power (torque and response).

- 4 wires motor : Set output current equals or less a little to the rated current.
- 6 wires motors in high torque mode: set the output current 50% to the rated current. (in unipolar wiring) ;
- 6 wires motors in high speed mode :Set the output current 100% to the rated current. (in unipolar wiring) ;

- 8 wires motors series connection: Set the output current 70% to the rated current. (in unipolar wiring)
- 8 wires motors paralleling connection: Set the output current 140% to the rated current. (in unipolar wiring).

▲ Note : After set the current, run the motor for 15 to 30 minutes, if the

temperature is too high (>70°C) , reduce the setting current.

Therefore, the proper current value should be set at the situation that the motor will running in normal temperature.

Typical connection

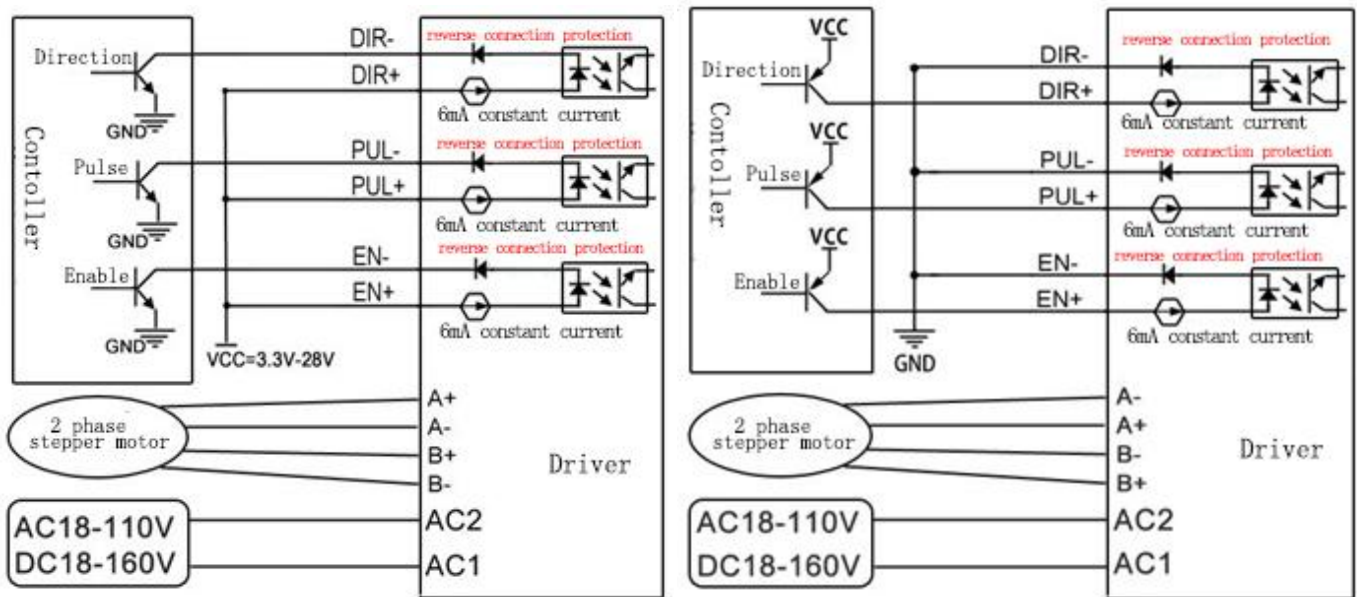

Note :

The color of the wire is different according to the different, check the motor specification before wiring.

Do not connect different phase windings to the same terminals of the Drive. (A+、 A- in the same phase , B+、 B- another phase) , exchange the A+、 A - terminals connection when you need to change the rotation direction.

This Drive is only used to drive 2 phase hybrid stepper motors, not for 3 phase or 5 phase motors .

Protection functions

- 1 green and 1 red light twinkle stands for over current.
- 1 green and 2 red light twinkle stands for open circuit.
- 1 green and 1 red light twinkle stands for over voltage.
- 1 green and 4 red light twinkle stands for under voltage.
- 1 green and 1 red light twinkle stands for other malfunction.

For any other questions, please contact our engineers:

Tel : +86 0755-27892991

Fax : +86 0755-27893359

E-mail : gdszph@gdszph.com